

ULTIMHEAT

HEAT & CONTROLS



JUNCTION BOXES, TEMPERATURE CONTROLS & ACCESSORIES FOR HEAT TRACING

- Enclosures & accessories for immersion heaters & temperature sensors:
- Explosion proof thermostats & heat tracing equipment:

See catalogue No.11

See catalogue No.4

Contact us



Because of permanent improvement of our products, drawings, descriptions, features used on these data sheets are for guidance only and can be modified without prior advice

Section 1	Summary			P1-P6
Section 2		Historical introduction		P1-P12
		Technical introduction <ul style="list-style-type: none"> - Introduction to various cables used in electrical heat tracing applications. - Design differences between products for domestic environments, industrial environments, and areas with an explosive atmosphere - Introduction to hexagonal crimping of round heating wires with fiberglass or aramid core or without textile core. - Introduction to heat shrinkable tubes. - Heating cable and wire terminations making. - Connection methods for cables and accessories with silicone filling, for field or workshop. - How to mount Y26, Y27 and Y28 boxes on pipe, using nylon cable ties. - Breakout forces of cable glands, gaskets, caps and cable terminations. 		P13-P18
Section 3	List of references			P1-P4
Section 4: Heat tracing connection boxes, connection on stripped conductors				P1-P32
Section 4		Y24	Connection boxes with two M24 cable glands and ceramic terminal block, for heat tracing applications. Maximum 16A.	P3-P5
		Y25	Connection boxes with three M24 cable glands and ceramic terminal block, for heat tracing applications. Maximum 16A.	P6-P9
		Y26	Connection boxes, with terminal block for 3 round or flat cables with metal braid, for heat tracing . 3 aligned M24 cable glands. Wall or pipe mounting. Maximum 16A.	P10-P14
		Y27	Connection boxes, with terminal block for 3 round or flat cables with metal braid, for heat tracing . 3 M24 cable glands at 90°. Wall or pipe mounting. Maximum 16A.	P15-P19
		Y28	Connection boxes, with terminal block for 4 round or flat cables with metal braid, for heat tracing . 4 M24 cable glands at 90°. Wall or pipe mounting. Maximum 16A.	P20-P24



<p>Section 4</p>		<p>Y29C Y29D</p>	<p>IP67 and IP69K connection box with pipe mounting foot, with internal 12-way terminal block, or Din rail, for connection of power supply, two heating cables and a temperature sensor. Available with 2 cable glands (M24 and M12) or with only one 5-way, 16A IP67 connector.</p>	<p>P25-P32</p>
------------------	--	----------------------	---	----------------

Section 5: Heat tracing connection boxes, **insulation piercing terminals for self-regulating cables, for application in industrial but non hazardous area**

P1-P16

<p>Section 5</p>		<p>Y40</p>	<p> II 2G Ex eb IIC T5 Gb</p> <p> II 2D Ex tb IIIC T95°C Db</p>	<p>TYPE Y40. Self-stripping junction box in PPS, with 2 M25 cable glands. Can be used on standard heating cable or explosion proof heating cable. Maximum temperature 95°C. Rating 32A, 6mm² Seals are selected in factory based on dimensions of heating cable sample received. Available with flat wall mounting bracket or with plastic or stainless-steel brackets for pipe mounting</p>	<p>6-12</p>
		<p>Y41</p>	<p> II 2G Ex eb IIC T5 Gb</p> <p> II 2D Ex tb IIIC T95°C Db</p>	<p>TYPE Y41. Self-stripping junction box in PPS, with four M25 cable glands. Can be used on standard heating cable or explosion proof heating cable. Maximum temperature 95°C. Rating 32A, 6mm² Seals are selected in factory based on dimensions of heating cable sample received. Available with flat wall mounting bracket or with plastic or stainless-steel brackets for pipe mounting</p>	<p>13-18</p>

Section 6: Mechanical thermostats inside housing, for **ambient temperature measurement, or with **remote probe****

P1-P16

<p>Section 6</p>		<p>49JB 4X</p>	<p>Fixed setting anti-freeze disc thermostats, for mounting in holes or threads for M20x1.5 cable glands. (This model also exists in explosion proof version, see catalogue 4)</p>	<p>P3</p>
		<p>Y22</p>	<p>Room thermostat, with built-in anti-freeze fixed setting thermostat, with 2 pilot lights. Internal connection block. Two M20 cable glands. Maximum 16A.</p>	<p>P4</p>
		<p>Y261</p>	<p>Connection box with built-in antifreeze fixed setting thermostat, with terminal block for 3 round or flat cables with metal braid, for heat tracing. 3 in line M24 cable glands. Wall or pipe mounting. Maximum 16A.</p>	<p>P5-P9</p>

Summary



Because of permanent improvement of our products, drawings, descriptions, features used on these data sheets are for guidance only and can be modified without prior advice

Section 6		YOD8 YOD9	Adjustable room thermostat, IP55 plastic housing, internal or external adjustment, one pilot light, pig-tail bulb. One, two, or three M20 cable glands for round or flat cables. Can be used for distribution to one or two heating cables. Also available with bulb and capillary distant sensor. Maximum 16A	P10-P11
		Y1A8G Y1B8G	Room thermostat, IP65, IK10 aluminium housing, internal adjustment under polycarbonate window. One pilot light , pig-tail bulb. Two M20 cable gland. Can be used for direct control of one heating cable. Also available with bulb and capillary distant sensor. Maximum 16A. 20A version is available. See catalogue 4 of products for hazardous areas	P12-P13
		YF7GNC	Room thermostat, IP69K, IK10, round plastic housing, Adjustment under screwed polycarbonate lid. Two pilot lights , pig-tail bulb. Two M20 cable gland. Can be used for direct control of one heating cable. Also available with bulb and capillary distant sensor.	P14-P15
Section 7 : Electronic controllers, for ambient temperature measurement, with built-in or remote sensor.				P1-P36
Section 7		2DNAP6	Electronic controller with digital display, DIN rail mounting , with remote temperature sensor, for antifreeze or temperature control of heating cables and pipes. On Off action with adjustable differential. Used to control directly one heating cable.	P3-P4
		Y1A2P Y1B2P	Electronic room thermostat, on-off action with low differential, IP65, IK10 aluminum housing. Internal set point adjustment. Two M20 cable glands for round or flat cables. Used to connect directly one round or oblong heating cable. 25A version is available. See catalogue 4 of products for hazardous areas	P5-P6
		YF62NC YF92NC	Adjustable electronic room thermostat with low differential, on-off action with adjustable differential, inside IP69K, IK10 plastic housing with transparent polycarbonate window. Two M20 cable glands for round or flat cables. Allows direct connection of one round or oblong heating cable. Available with built-in or remote temperature sensor.	P7-P8
		Y8WR-X Y8WR-Y	Industrial electronic thermostat , graduated knob set point adjustment, wall-mounting , for remote control of trace heaters , to be used combination with a connection box Y26, Y27, Y28, Y29, Y40, Y41. IP69K ingress protection. Adjustment by graduated knob. On-Off action. Output by 3 cable glands or by 5-ways connector. Can receive a rear stainless-steel bracket for pipe mounting.	P9-P11

Summary











Section 7		<p>Y8WH-X Y8WH-Y</p>	<p>Industrial electronic temperature controller, digital display, wall-mounting, for remote control of trace heaters, to be used combination with a connection box Y26, Y27, Y28, Y29, Y40, Y41. IP69K ingress protection. Adjustment by graduated knob, On-Off action. Output by 3 cable glands or by 5-ways connector. Can receive a rear stainless-steel bracket for pipe mounting.</p>	P12-P14
		<p>Y8WJ-X Y8WJ-Y</p>	<p>Industrial electronic temperature controller, double digital display, wall-mounting, for remote control of trace heaters, to be used combination with a connection box Y26, Y27, Y28, Y29, Y40, Y41. IP69K ingress protection. Adjustment by graduated knob, PID action. Output by 3 cable glands or by 5-ways connector. Can receive a rear stainless-steel bracket for pipe mounting.</p>	P15-P17
		<p>Y8WR-Z</p>	<p>Industrial thermostat IP69K, IK10, adjustment under polycarbonate window, two indicator lights. Includes a pipe mounting foot and a gasket in the foot allowing the passage of 1 or 2 self-regulating cables up to 6 × 13mm, and a thermostat capillary. Connection of the power supply by an M25 cable gland. Available in room temperature control with incorporated probe, or with remote probe.</p>	P18-P22
		<p>Y8WH-Z</p>	<p>Industrial temperature controller with digital display, on-off action. IP69K, IK10 enclosure, adjustment under polycarbonate window. Fitted with one pipe mounting leg allowing to receive 1 or 2 self-regulating cables up to 6 × 13mm, and one temperature sensor cable. Also fitted with one M25 cable gland for the power cable. Available in room temperature control with built-in or with remote temperature sensor.</p>	P23-P27
		<p>Y8WJ-Z</p>	<p>Industrial temperature controller with double digital display, PID action. IP69K, IK10 enclosure, adjustment under polycarbonate window. Fitted with one pipe mounting leg allowing to receive 1 or 2 self-regulating cables up to 6x13mm, and one temperature sensor cable. Also fitted with one M25 cable gland for the power cable. Available in room temperature control with built-in or with remote temperature sensor.</p>	P28-P32
		<p>TSR5 TNR6</p>	<p>Standard temperature sensors Pt100 and NTC for use in heat tracing.</p>	P33-P34
		<p>TSJB TNJB TPJB TJJB</p>	<p>Pt100, J and K thermocouples or NTC temperature sensors, for mounting in holes or threads for M20x1.5 cable glands.</p>	P35-P36

Because of permanent improvement of our products, drawings, descriptions, features used on these data sheets are for guidance only and can be modified without prior advice



Because of permanent improvement of our products, drawings, descriptions, features used on these data sheets are for guidance only and can be modified without prior advice

Section 8: Various assemblies made on heating cables supplied by customer				P1-P6
Section 8		49C	Fixed temperature thermostats, overmolded on heating cables and power supply cables (Only for <u>large</u> quantities production on customer's cables)	P3-P4
		9UW	Over-moulding of power supply cord and free end cap on self-regulating heating wires or others supplied by customer.	P5-P6
Section 9 : Heating cables terminations and small accessories				P1-P50
Section 9		6YTDKA & 6YTDKB	Silicone sleeves for connection of heating cables and power supply cords on thermostats (field or workshop assembly). Overmolded cord with incorporated thermostat, mounts on oblong heating cables, of the self-regulating parallel type or of constant power. Connection by crimping or soldering. Sealing of the connection by silicone sleeve + RTV or by heat-shrink tubing.	P3-P9
		6YTNL	Silicone sleeves for connection of thermostats on heating cables (field or workshop assembly). Installation on the free end of the heating cable, for oblong heating cables, limited to series types with two side by side bus wires. Connection by soldering. Sealing of the connection by silicone sleeve + RTV.	P10-P13
		6YTNM	Silicone sleeves for connection of heating cable on power supply wires (field or workshop assembly). Filling with room temperature vulcanizing silicone resin (RTV)	P14-P17
		6YTNE	Termination caps for closing the free end of round and flat heating cables (workshop or field use). Can be mounted dry, or filled with room temperature vulcanizing silicone resin (RTV).	P18-P19
		6YTEW	Self-clamping waterproof PA66 termination caps (End seals) for closing the free end of round and flat heating cables. IP67. No need for silicone filling or adhesive. Also exists in explosion proof version. see catalogue 4	P20-P22
		6YTNI	55 shore black silicone caps, for termination of the free end of round or flat heating cables for self-regulating type cables, constant power type, or series type with one or two conductors side by side. Includes a filling system with silicone resin vulcanizing at room temperature (RTV), usable without special tools on site or in the workshop.	P23-P24
		6YTNI	Sheathing and insulation boot for self-regulating heating cable conductors after removal of the heating zone. (This insulation is mandatory because the residual semiconductor plastic sheathing the bus wires is not an electrical insulator)	P25-P29

Summary



Section 9		6YTP	M20 and M24 cable glands with gaskets for round, oblong and self-regulating cables.	P30-P34
		6YTBA	Stainless steel devices for mounting temperature sensors and thermostat bulbs on pipes surface. Flexibles, they provide a permanent thermal contact with the pipe	P35
		6YTB	Bands for mounting electric heat tracing cables on pipes, on roofs or on the floor.	P36-P37
		6YTQS	Support in stainless steel for mounting M20x1.5 disc thermostats and M20x1.5 temperature sensors on pipe walls.	P38
		6YTQT	Stainless steel mounting feet for connection boxes with or without insulation piercing, snapped-on or screwed on the bottom of the boxes. Mounting on pipes by nylon ties or metal clamps.	P39-P40
		6YTPP	Heat tracing pipe mounting feet for connection boxes, includes gasket for flat self-regulating cables up to 6 x13mm, and for temperature sensor. Patented self-locking of the gasket tightening. (1" thread).	P41-P44
		6YTCCO	Tinned tubular copper terminals for connecting heating wire conductors end to end by hexagonal crimping.	P45-P48
		6YTMC	Fluid RTV silicone for filling , temperature resistance 280°C, in 45ml tubes, with injection nozzle.	P49

Section 10 : Special tools

P1-P8

Section 10		6YTTL03	Exclusive hexagonal crimping plier for wires (exclusive model).	P3
		6YTTL04	Exclusive stripping pliers for heat tracing cables with dedicated cutting blades according to all cable dimensions.	P4-P6
		6YTTL05	Exclusive tool for cutting the heating zone between the conductors (for flat self-regulating cables). Also allows to cut one of the two conductors and its insulation over 5mm in order to maintain safety isolation distances at the end of self-regulating heating cables (exclusive model).	P7-P8

: These products are not made by Ultimheat

Update 2026/05/07

Because of permanent improvement of our products, drawings, descriptions, features used on these data sheets are for guidance only and can be modified without prior advice



Because of permanent improvement of our products, drawings, descriptions, features used on these data sheets are for guidance only and can be modified without prior advice

Section 2

Historical introduction to electric flexible heating cables



Because of permanent improvement of our products, drawings, descriptions, features used on these data sheets are for guidance only and can be modified without prior advice



Because of permanent improvement of our products, drawings, descriptions, features used on these data sheets are for guidance only and can be modified without prior advice

Historical introduction to electric flexible heating cables Heated cables and cords. First applications in horticulture and the early stages of anti-frosting using electricity

Around 1925, a Norwegian engineer named C. Jacobsen noticed that the snow had melted and that the vegetation was clearly visible all along the underground power lines. From there came the idea of using heating wires to increase the growth rate of crops. Thus, this area of heating was born, which progressed rapidly because of its numerous technical and economic advantages, and which quickly attracted German, Dutch and French horticulturists.

In 1928, in the south of Alsace, an electricity producer, (the Société des Forces Électriques Sundgoviennes), implemented an original system for reheating and thawing drinking water supply pipes, using the resistivity of iron pipes. This on-demand service, carried out house by house by a van specially fitted out with a low-voltage transformer, made it possible to thaw frozen underground pipes, by simply having access to both ends of them.

The two secondary terminals were then connected by 25mm² cables to the two ends of the pipe to be thawed. Depending on the length of the pipes to be treated, currents of 50 to 150 amperes were used. The heating resistance was then the metal tube itself.

(1929 BIP Electricity Information and Propaganda Bulletin N 10)

In some countries, a similar technique was used for heating layers in horticulture. The heating element was then a simple galvanized iron mesh, placed inside the ground, and power supply was made at each end by a low voltage transformer.

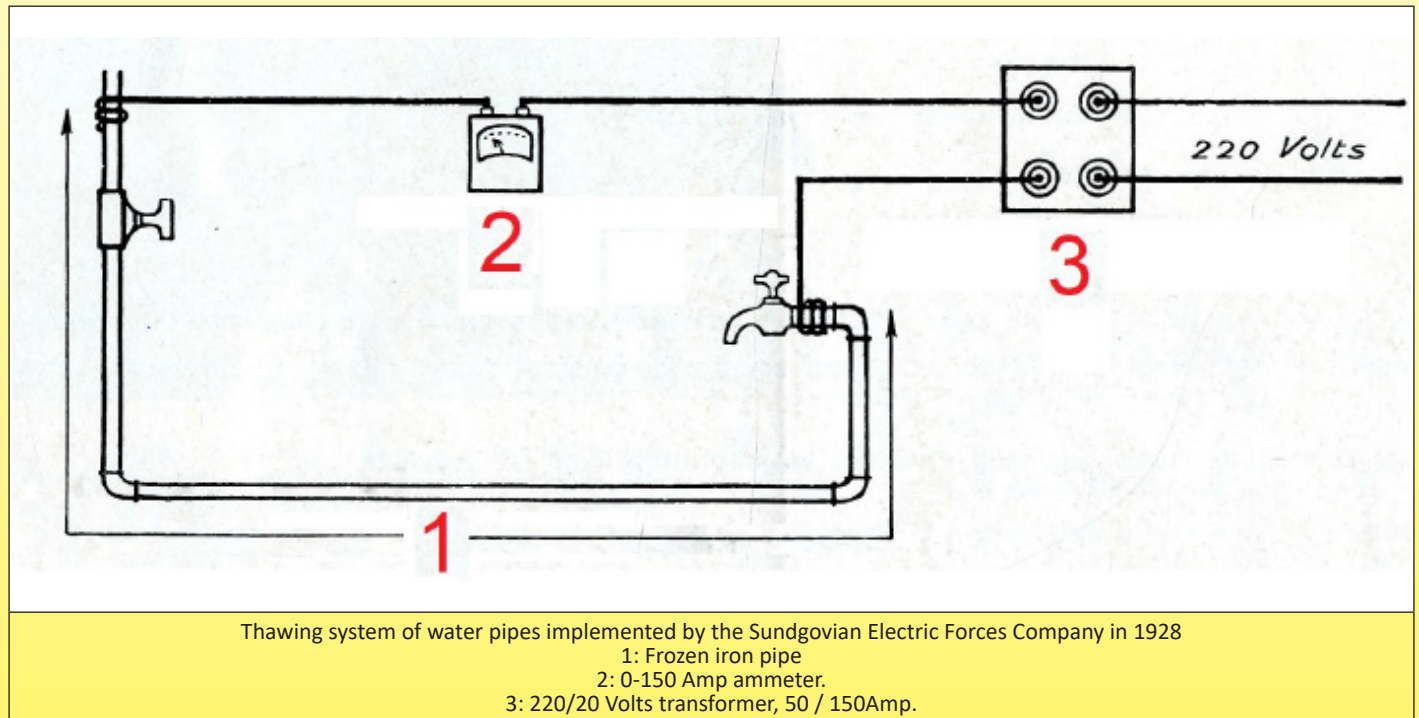

From the beginning of 1929, experiments on electrically heating the soil for vegetable production were carried out at the Fontaines School of Agriculture in Saone et Loire (*Ruling by the general council of Saone et Loire, August 1929*).

In Holland, the first heated cables for horticultural use were installed as an experiment during the winter of 1929 - 1930 in The Hague, Delft and Rotterdam. They had been produced by the Swedish company Sievert de Sundyberg. They consisted of a 0.73mm diameter resistor wire, with a linear resistance of 1.10 ohm per current meter. Two coils of asbestos helically wound in the opposite direction, then a layer of impregnated paper, and finally a 1.3mm thick lead sheath ensured the insulation and mechanical protection of the resistor wires. The outer diameter of this heating cable was 4.7mm. The lead sheath, with a linear resistance of 0.13 ohm, also acted as a return current conductor. For this purpose, the free end of the cable was welded to the resistor wire. Each 50m long cable can be charged up to 5 A or 22W/m (*1931 BIP Information and Electricity propaganda N 37*)

In countries with a harsh climate, such as the Scandinavian countries and Germany, heated cables buried at 30 centimeters maintained the temperature of greenhouse layers. The current at night could be set to a very low rate, and the savings in heating costs are estimated to be around at 75%. (*Le Temps, April 27, 1932*)

1936 To speed up the growth of early vegetables, horticulturists are making use of layers of crops covered with glass. Successful experiments with electrically heated layers were well received in various regions of France and abroad. For this purpose, controlled trials were carried out in Nice from February 1 to 15 May 1935. The heating cable consisted of a cable reinforced with a nickeline conductor, and was 12/10mm in diameter. The power input was about 3 kW, or about 200 watts per square meter of land area. [NB : Nickeline was an alloy of copper, zinc and nickel, similar to nickel silver, and manufactured by the German company Obermaier] (*1936 BIP No. 93, Ultimheat Museum**)

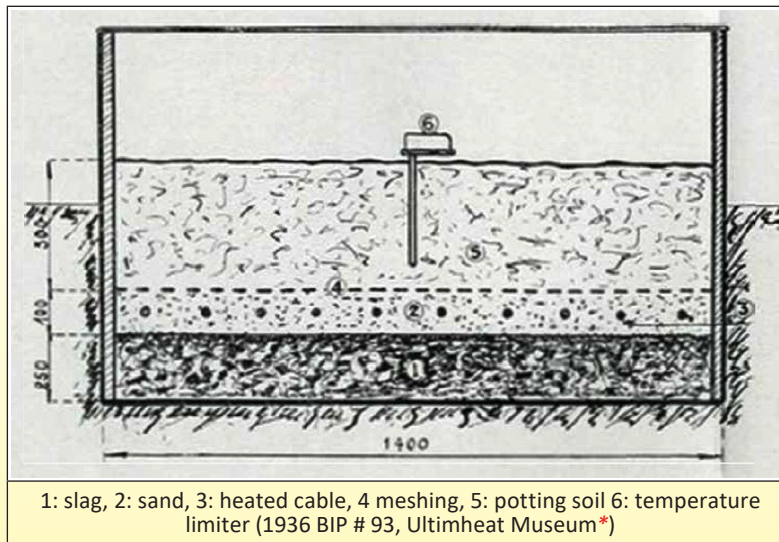

1: slag, 2: sand, 3: heated cable, 4: meshing, 5: potting soil 6: temperature limiter (1936 BIP # 93, Ultimheat Museum*)

Horticultural applications using electric layer heating developed rapidly in France, and this type of heating cable was quickly standardized with two main French suppliers: Câbles de Lyon and Alsthom, using a straight heating wire. There was also a Dutch supplier, the Hollandse Draad in Kabelfabriek (Draka) from Amsterdam, that used spiral heating wire around an asbestos core.

Heating cables were a very special solution to the problem of heating elements, and they have since been widely adopted in the agricultural field for heating crops. However, these cables can be used industrially for relatively low voltages and low temperatures (up to 80°C on the cable surface), particularly in order to spread the heat as evenly as possible. There are currently three types of heating cables, which are listed below in alphabetical order:

- A / Starting from the center to the periphery, the Alsthom cable comprises a resistant nickel-chromium wire with two impregnated cotton pads, a triple asbestos braid, a wrap of impregnated paper, pure lead casing and, in some cases, an additional sheath or strip of striated electrolytic zinc was added to avoid electrolysis resulting from stray currents. The diameter of the bare lead cable is approximately 6mm and the resistivity may vary from 0.5 to 2 ohms per meter (in general, an amount equal to 1 ohm per meter is chosen). The maximum specific power is 30 W per meter or about 33 m.

- B / The Câblerie de Lyon cable was made of a resistant wire insulated with layers of asbestos and tar paper and wrung out. The whole system was coated in a lead sheath and protected against chemical corrosion by special treatment (sulphurization), and then covered with impregnated paper and sheet armor. The specific power varies from 25 to 40 W / m in general.

- C / The Draka cable (produced in Holland) is normally comprised of a nickel-chromium wire rolled on an asbest core (product made from asbestos) and surrounded by a mixture (of which we do not know the composition), which forms the electrical insulator and thermal conductor. The whole system is covered with a layer of pure lead. In some cases the cable is armed, the lead casing is asphalted, wrapped in impregnated paper, and then reinforced with 2 layers of sheeting, asphalted again and finally wrapped with impregnated paper. The outside diameter of the unarmed lead wire is 4.15 to 6.5mm. The specific power is usually 30 W / m.

Heating cables have three interesting advantages in particular: ease of use; resistance to certain chemical agents (pure lead sheath); low price (for example, a 1kW cable is currently worth about half the price of a magnesia-coated tube with the same power).

(1938 Protected Elements, Gautheret, Ultimheat Museum*)

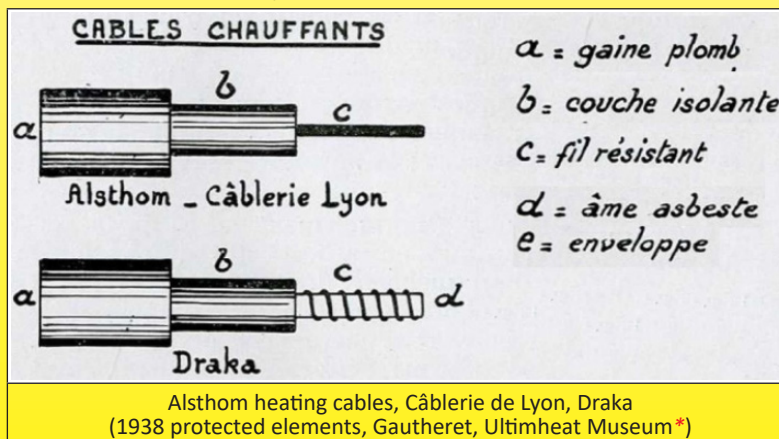

1938 The heating cable is deemed the heating device that best meets the needs of horticulture. It consists of a high-resistance alloy conductor (nickeline, nichrome, nickel, constantan), insulated with several layers of asbestos and impregnated paper, and mechanically protected by a lead sheath covered with an anti-corrosive coating, and sometimes double coated with a steel sheet. The metric resistance of the cable to be installed depends on the length needed to obtain an equal distribution of the desired heat on a given surface.

Manufacturers are building cable types of various strengths, ranging from 0.15 to 2.55 ohms/m, to meet all needs (1938 modern technology, electrical horticulture applications).

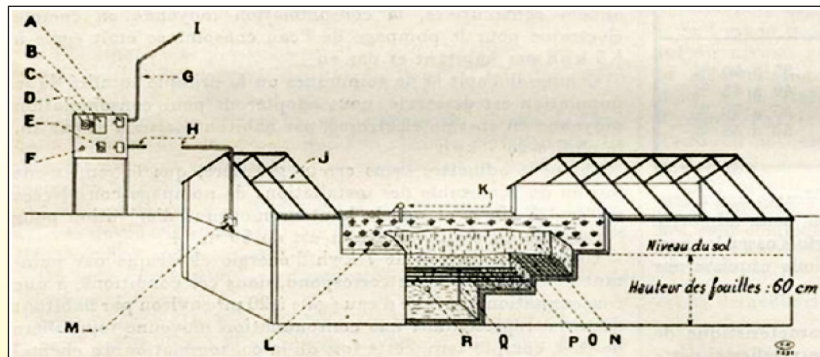

FIG. 1. — Coupe d'une bêche chauffée par câbles électriques.

A, Combiné étanche avec compteur; — B, Compteur; — C, Horloge de commande du compteur; — D, Combiné de départ; — E, Horloge de commande du chauffage; — F, Lampe témoin indiquant si la couche est en chauffage; — G, Tube d'acier pour arrivée; — H, Tube d'acier pour départ vers la couche; — I, Vers la ligne d'amenée aérienne; — J, Châssis vitré; — K, Thermostat; — L, Plantes; — M, Boîte de raccordement; — N, Terre de culture (25 cm); — O, Grillage de protection des câbles; — P, Sable (10 cm); — Q, Mâchefer (25 cm); — R, Câbles chauffants.

Horticultural plant heated with electricity (1938 modern technique, electrical heating applications for horticulture.)

In 1956, 2,500 French farms were equipped with it, with a total installed power of about 5000kW, and an annual consumption (exclusively at night) of 3 to 4 million kWh.

Heating using buried flexible cables. 1956 Electric horticulture heating (Ultimheat Museum*)

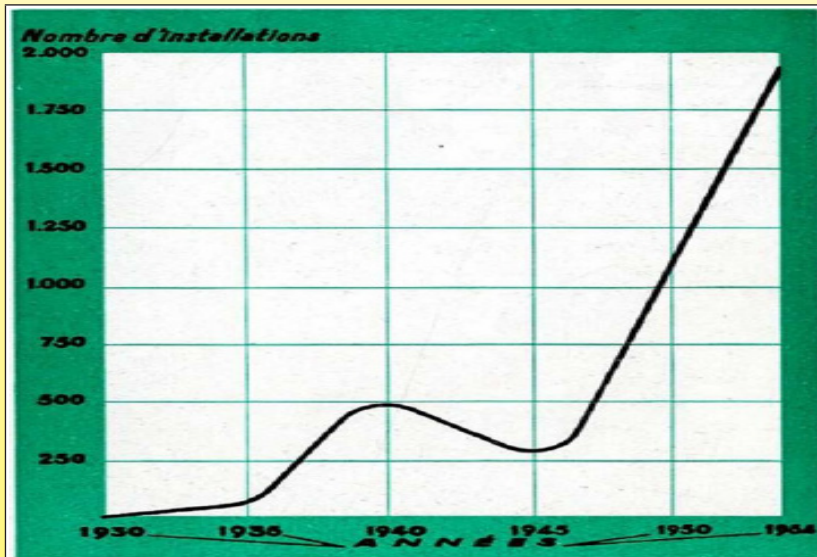

Variation in the number of soil heating operations in service since 1930. (1956 Electric heating in horticulture, Ultimheat Museum*)

In 1957, the EDF manual describes electric heating applications in horticulture. Recommended values range from 150 to 200 W/m² for outdoor awnings and 80 to 120 W/m² for greenhouse shelves.

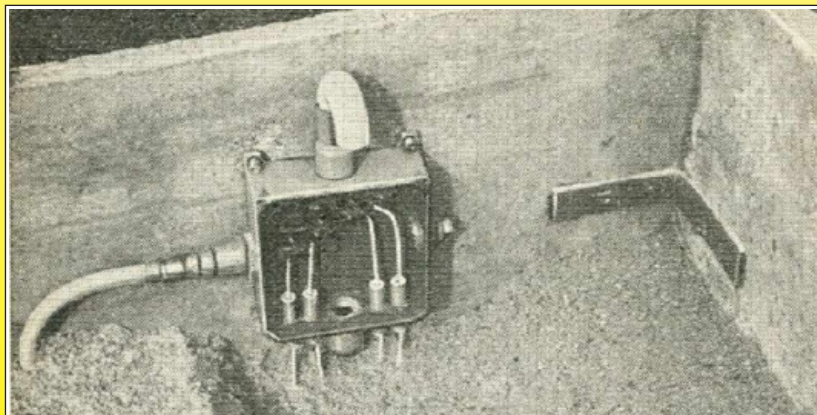

Electric heating of the ground, with the arrival of heating cables (1957, EDF Manual, Ultimheat Museum*)

Miscellaneous applications of heating cables

The appearance in 1929-1930 and the development of heating cables for horticultural use gave rise to other applications. Waterproof and coated with a mechanical protective lead casing, they could easily be used on their own. It was no longer necessary to have them integrated into an envelope like the heating wires of fabrics and small household equipment. The lead shield kept the cable flexible while providing some temperature resistance. Insulator technology evolved to have a higher temperature resistance and that gradually increased the range of applications.

As early as 1937, in Sweden, the electric floor heating of a sports field was carried out.

As early as 1938, some industrial achievements had already been made with some of these heating cables, such as drying ovens for glazed wire, heated water pipes to prevent freezing, tanks for photographic solutions, and paraffin tanks. These cables were then used in low-temperature heating for liquids and air, such as in drying ovens, chamber-ovens, walls and heated floors. (1938 Protected Elements, Gautheret)

In the USA, the Michigan state Highway received electric heating near Ferndale in 1948.

In cold countries, in Europe, trials of heating roads and bridges using electric heating cables began in 1956 in Switzerland, on the Walensee Strasse between Zürich and Cloire. Similar tests took place the same year in England and the following year in Germany at the Montabaur Bridge on the Frankfurt-Cologne route.

1963 saw the first French example of domestic heating: a heating cable embedded in the floorboards. It was presented at the international construction exhibition by the company Panélaç. It worked by thermal accumulation during "off-peak hours" (1963 Domestic equipment N92, Ultimheat Museum*)

It was followed in 1966 by the heating of the interchange of the Porte de la Chapelle in Paris (Electric heating of the roadways, by Robert Félix, 1971, Ultimheat Museum*)



1969 Laying asphalt on the upper carriageway of a Hammerschmidt junction in London
(Electric heating of the roadways, by Robert Félix, 1971, Ultimheat Museum*)



1968 Installation of the heating web on an access ramp to a bus parking platform, Orly airport near Paris (Electric floor heating, by Robert Félix, 1971, Ultimheat Museum*)

In 1966, as with heat blankets, silicone modified the design of flexible industrial heating cables and fabrics.

On the market, we began to find heating cables consisting of a single or double Fe-Ni-Cr or nickel-silver resistor wire, electrically protected by sheaths or braids of glass wool, or glass wool and silicone rubber.

For industrial applications (drying ovens, liquid heating) and agricultural heat tracing, these heating cables were mechanically protected by flexible sheathing made from either lead, steel or copper. Their diameter ranged from 4 to 9mm, for a linear resistance of 0.25 to 100 Ω per meter, and a general power of 30 to 40 W/m. (1966 Electric Heating elements, Ultimheat Museum*)

The development of self-regulating polyethylene-carbon cables in the late 1960s opened a new path for the electric heat tracing market, after their initial applications in domestic heated blankets stagnated.

A few years later in 1975, tests for pavement heating with heating cables were tested in the Cher region (Official Journal of 14 January 1976)

Flexible heating cords, with PVC, silicone, PTFE or polyolefin insulation, using resistive or self-regulating metal conductors, became an important new area of electric heating, with new opportunities opening up as new products emerged. Examples included heating cords for refrigerated windows, electric tracing heated cables, anti-freeze systems for pipe networks, road de-icing, roof snow removal, frost protection for meters, and domestic electric floor heating.

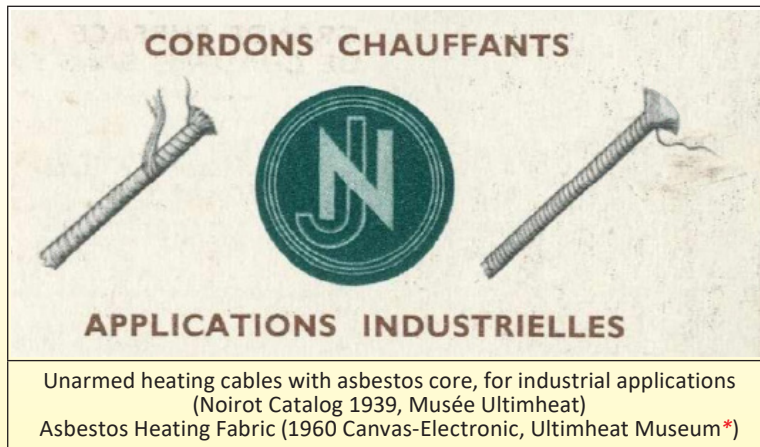

Another important application is that of heating cords, consisting of a calibrated asbestos bead on which the metal conductor is wound and covered (or not) with asbestos braiding or other insulating substances". (1966 Electric Heating elements, Ultimheat Museum*)

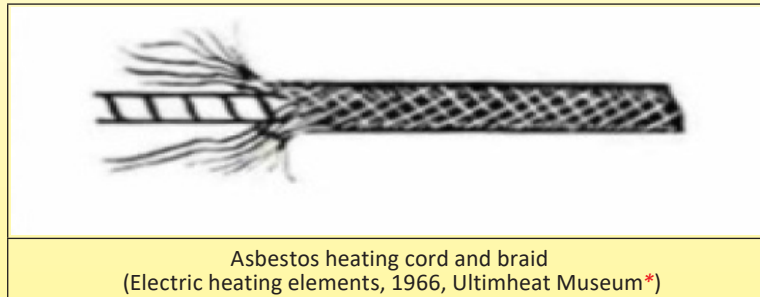

In August 1977, awareness of the danger of asbestos led to a first decree on the protection of workers exposed to asbestos dust, followed by a total ban of asbestos in France in 1997. As a result, these types of heating elements disappeared from the market.



Technological evolution of heating elements Metal heating wires

When Camille Hergott developed his first flexible heating elements, his research was focused around nickel conductors. He made this choice because of the high temperature coefficient, making it rustproof and self-regulating (thanks to its double resistivity between 20 and 200°C). Other metals used at the end of the 19th century for heating elements were platinum (expensive), iron (oxidizable), nickel silver (low temperature coefficient), and copper (very low resistivity).

Ferro-nickels, which appeared shortly thereafter, made it possible to limit the length of the heating wires required, because they had greater resistivity. The most resistive alloy used for heating elements was 30% iron and 70% nickel. Its resistivity varied little with temperature (temperature coefficient of 0.0009°C i.e. 5 times less than pure nickel at 0.0054). They were basically rustproof at high temperatures, and so were mainly used in stoves, radiators, and toasters.

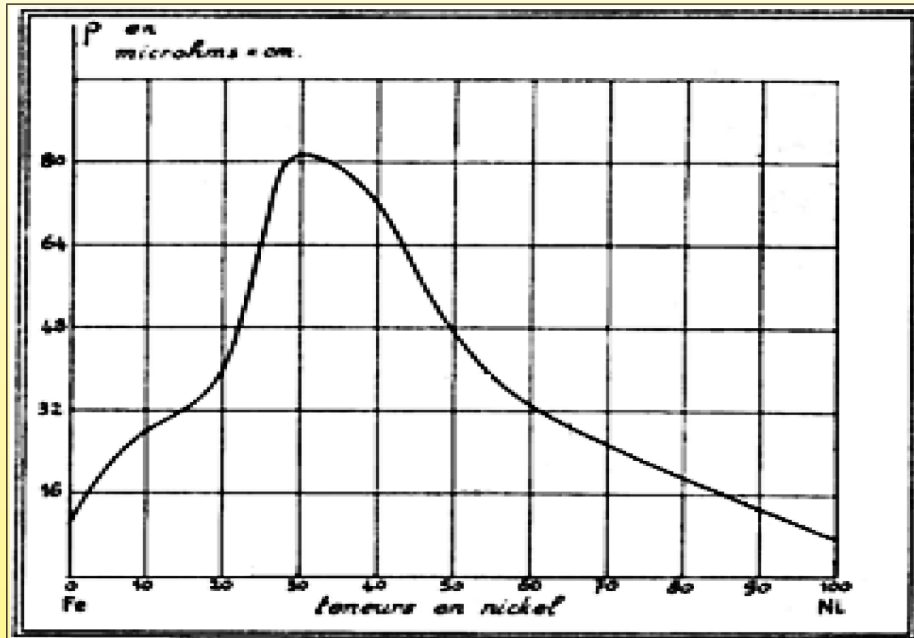

Variation in resistivity: curve according to nickel content in ferro-nickel alloys (La Nature, 1934, Nickel alloys and their applications, P215)

The development of nickel alloys from 1900 to 1940 gave rise to nickel-chromium resistive alloys and multiple copper-nickel alloys. As for ferro-nickels, high resistivity and temperature resistance were the main parameters for using these products. The alloys also had to have a low temperature coefficient, such as constantan and 'Advance' by Driver-Harris, so that their characteristics were not affected by temperature. Their use in heated blankets and thermoplasms required the addition of a temperature-limitation system.

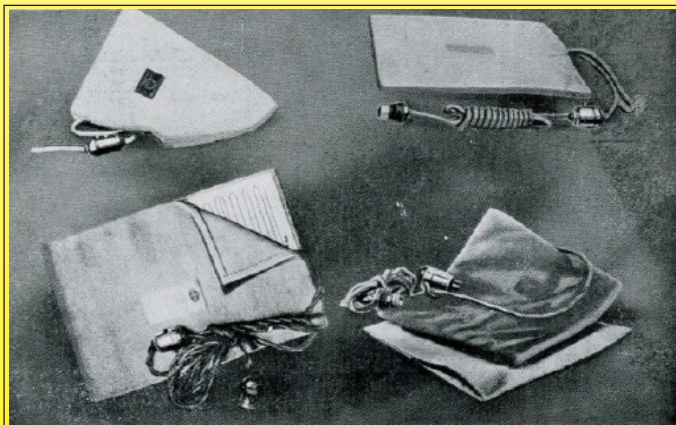

1930 Electric compress with Advance heating elements (Drivers Harris, 1930 catalog, Ultimheat Museum*)

ALLIAGES R. N. C. POUR RÉSIDANCES ÉLECTRIQUES

Propriétés	RNC-1	RNC-2	RNC-3
Résistivité à 15°.....	100 ± 4 microhms/1/100m ²	111 ± 4 microhms/1/100m ²	102 ± 4 microhms/1/100m ²
Coefficient de température de la résistivité, valeur moyenne entre	0 à 0,000 0,30 à 0,35 × 10 ⁻³	0 à 0,800 0,10 à 0,15 × 10 ⁻³	0 à 1,000 0,05 à 0,08 × 10 ⁻³
Pouvoir thermoélectrique par rapport au cuivre	+ 2 à + 2,5 microvolts par degré	0 à + 0,7 microvolts par degré	+ 5 à + 6 microvolts par degré
Densité	8,05	8,25	8,45
Point de fusion.....	1.450°	1.450°	1.475°
Température limite d'emploi.....	600-700°	900-1.000°	1.100-1.150°
Applications.....	Rhéostats, Chauffage aux températures moyennes, Cuisine électrique, Chauffage domestique.	Radiateurs, Chauffage aux températures élevées, Fours à traitements, Appareils de mesures.	Radiateurs lumineux, Chauffage aux températures très élevées, Appareils de laboratoires, Résistances de mesures.

1933 Imphy's steel plants offer resistive wires in 3 different nickel-chromium alloys, which they call RNC 1, 2 and 3 (Resistive Nickel Chrome). RNC1 was well suited for heated blankets. It had a large increase in resistivity in relation to temperature, which provided a self-regulating effect (0.0030 to 0.0035 Ω / Ω / °C)

Historical introduction to electric flexible heating cables



Because of permanent improvement of our products, drawings, descriptions, features used on these data sheets are for guidance only and can be modified without prior advice

Around 1934, Harris produced a 28% iron and 72% nickel alloy with a high temperature coefficient; it was called Hytemco (High Temperature Coefficient) This alloy had a temperature coefficient of 0.0048 to $0.0053 \Omega / \Omega / ^\circ\text{C}$, making it very close to pure nickel. But its resistivity was twice as high, which made it possible to reduce the length of the necessary wires. Used in heated blankets, it provided an important self-regulating function.

Over the years, Driver Harris developed a range of alloys with a high temperature coefficient, in particular:

- 99 alloy: (99.8% pure nickel): $0.006 \Omega / \Omega / ^\circ\text{C}$
- Nickel grade A: $0.005 \Omega / \Omega / ^\circ\text{C}$
- Nickel grade E: $0.0045 \Omega / \Omega / ^\circ\text{C}$
- Hytemco: $0.0045 \Omega / \Omega / ^\circ\text{C}$
- Permanickel: $0.0036 \Omega / \Omega / ^\circ\text{C}$
- Alloy 152: $0.0035 \Omega / \Omega / ^\circ\text{C}$
- Alloy 146: $0.0032 \Omega / \Omega / ^\circ\text{C}$

Similar alloys were developed by other metallurgists under the names Alloy 120, MWS-120, Balco, HAI-380, NIFE 5200, Kanthal 70, Alloy K70, Nifethal 70, and Pelcoloy.

Self-regulating polymer heating cables with positive temperature coefficient

In 1962, an important discovery was made at Douglas Aircraft laboratories (US Pat. No. 3,238,355) on polymers and, in particular, on polyethylene loaded with carbon nanoparticles, which is a semiconductor at room temperature. It was found that this material, at a temperature of around 70°C, saw its resistivity rise sharply as a quasi-electrical insulator (*"Electrical Properties of Black Carbon Filled Polyethylene"*, *Polymer Engineering and Science*, Jun. 1978, vol. 18, No. 8, pp. 649-653. *"Polyethylene / Carbon Black Switching Materials"*, *Journal of Applied Polymer Science*, vol. 22, 1163-1165, 1978, Wiley & Sons, NY)

As early as 1966, General Electric engineers Phillip A. Sanford and William P. Somers devised flexible conductors using this property to make resistors for heated blankets. This eliminated the need for safety limiters, as the heating pad adjusted its power automatically as soon as the temperature became too high. The most comfortable power for the heating cords in ambient temperature was found to be 3 to 3.8 watts per meter.

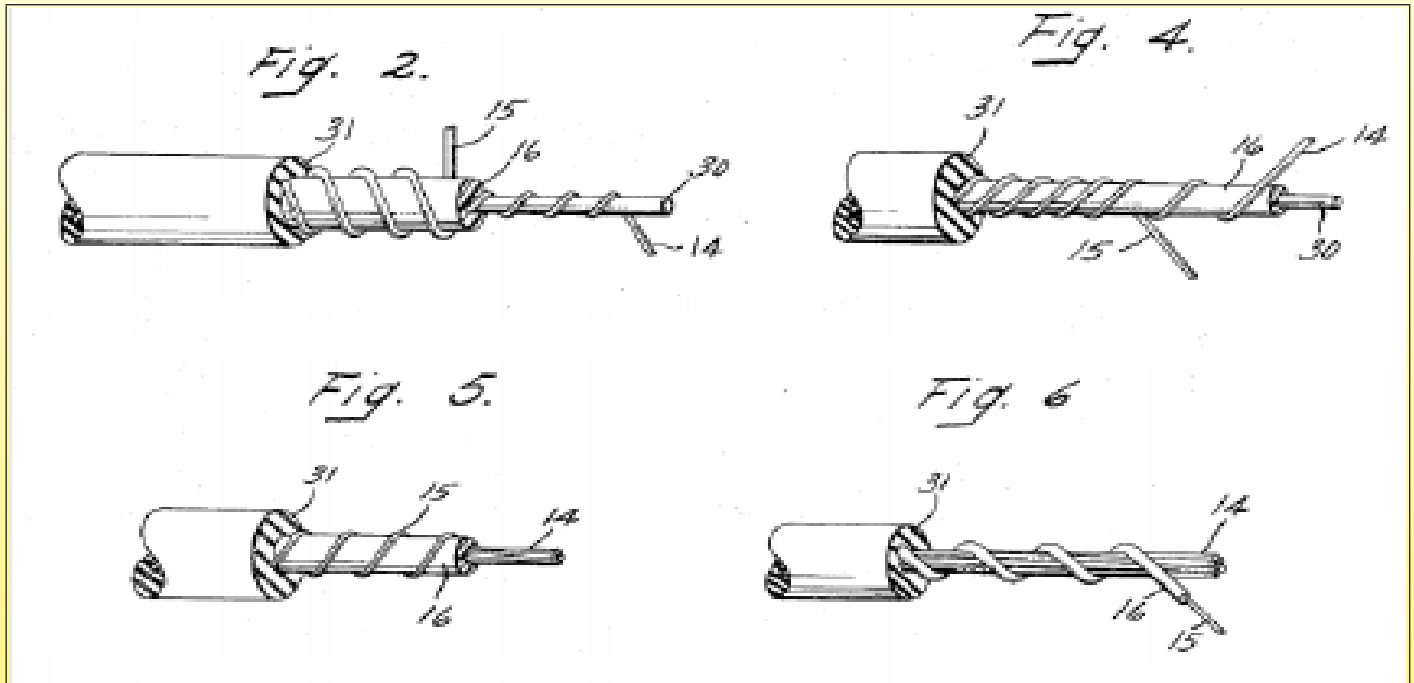

1966 First self-regulating heating cords for heated blankets (US Pat. No. 3410984, Phillip Sanford, for General Electric)

Depending on the composition of the polymer, its percentage of carbon particles and its thickness, it was possible to obtain different stabilization temperatures. However, in addition to its cost, the lack of flexibility of this highly charged 27% carbon polymer made the heating cords relatively stiff, and lacking the flexibility required for heated blankets. In addition, two major technical problems quickly emerged that prevented commercialization.

The first was related to the high contact resistance between the conductors and the polyethylene semiconductor, due to the difficulty of joining the two. The second problem was the poor stability of the heating element, which had lower resistivity, presumably because of the high operating temperature and thermal cycles. It took more than 10 years to resolve, and it was not until 1980 that Sunbeam, the American heated blanket manufacturer, filed patent 4271350 for a reliable version of heating cables with a positive temperature coefficient. In this technical evolution, the heating cord underwent a thermal annealing cycle at a temperature of around 150°C. This was greater than the melting temperature of polyethylene, which required a high-temperature over-sheathing of thermoplastic elastomer and special precautions so that the conductors did not touch during annealing. Sunbeam's various versions of electric blanket applications also improved the flexibility of the heating cord.

At the beginning of 1984, Sunbeam heated blankets using this type of conductor, without thermostats, appeared on the American market.

This technology continues to be used almost exclusively by Sunbeam in the USA. It allows production of blankets with high calorific value, but, although reduced, the original defects are still present, such as lack of flexibility, and loss of heating power due to aging of the PTC polymer.



Because of permanent improvement of our products, drawings, descriptions, features used on these data sheets are for guidance only and can be modified without prior advice

Recent technological developments of flexible heating conductors.

- Polymer ribbons with conductive plating: these ribbons are spiraled around a fiberglass core. With their extreme flexibility, they can create small diameter cords that can be incorporated into fabric manufacturing.
- Metallic micrometric ribbons wrapped around a cotton, synthetic fiber, or fiberglass core. These ribbons also make it possible to produce cords with a very small diameter (up to 0.27mm), which can be easily integrated into fabrics (2004)
- Self regulating silicones. These silicones are made up of a filler in carbon nanoparticles, similar to PE and PP (*US Patent: 6.734.250 dated August 17, 2000 Shin Etsu chemical*).
- Polymeric fibers with surfaces metalized with plasma or electroplating.

A few words on other technologies used in electrical tracing, and rigid or non-flexible heating systems

Mineral insulated shielded heating cables.

Not very flexible, these cables, made up of a heating wire insulated with compressed magnesia, shielded by a stainless-steel tube, offer an excellent mechanical resistance. This technique began to be used in the field of horticultural heating, for small areas, around 1936, when the company Thomson (Als-Thom) marketed the Calrod American heating elements.

Given the very high temperature resistance of this system (+ 600°C), these elements are currently used for high temperature heat tracing applications.

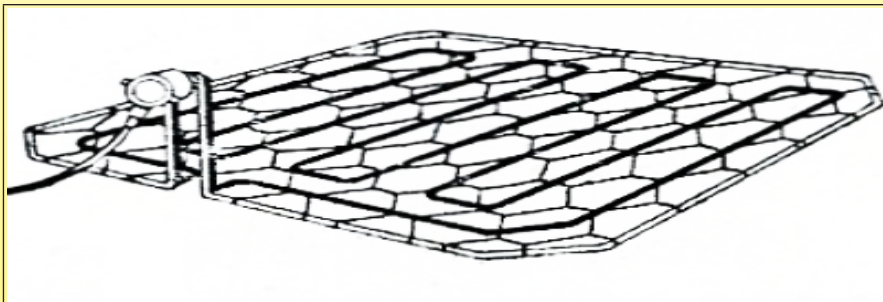

1956, example of a 1.5m² grid, supporting a sheathed heating element, for heating layers in horticulture. (1956 Electric heating in horticulture, Ultimheat Museum*)

Electric tracing with skin effect, also named eddy current.

This technical solution, in which a ferromagnetic tube is used, in which an insulated electrical conductor is passing, is based on the eddy currents induced by an alternating current in the interior surface of the wall of the tube. Although their first applications date from the 1950s /1953s for domestic tubular radiators (US patent 2,635,168 for Patko Cy), it was not until 1965, in Japanese patent 460,224 (In the USA: 3,293,407 by Masao Ando) that appears a tube with skin effect associated with a piping, for the transport of hydrocarbons. This solution, inexpensive, will be strongly used thereafter for the reheating in the pipes of great length. It also have the advantage of not producing voltage on the outside surface of the metal tube.

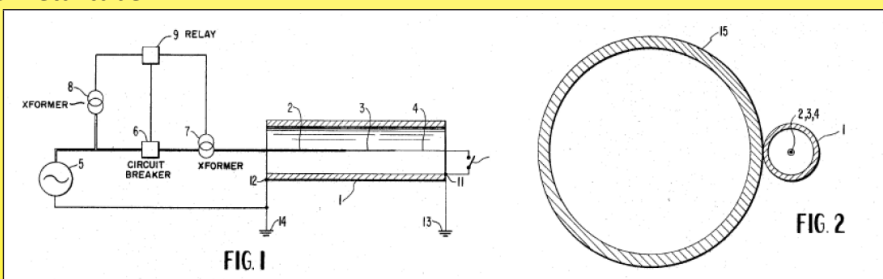

Excerpt from a 1968 Masao Ando patent for the Chisso corporation in Osaka, describing the heating of pipelines by an eddy current heating tube



* : Original document of Ultimheat museum
** : Picture of a device of the Ultimheat collection



Because of permanent improvement of our products, drawings, descriptions, features used on these data sheets are for guidance only and can be modified without prior advice

Technical introduction



Because of permanent improvement of our products, drawings, descriptions, features used on these data sheets are for guidance only and can be modified without prior advice



The different methods of preparing the ends of heating cables

There are many methods for preparing the ends of heating cables.

The manufacturers of these cables often ignore these operations, even though they represent a significant part of the installation cost. They are more or less time consuming and tedious depending on the types of cables and the tools used. We set up comparative tests to select the fastest solutions and design the most efficient tools.

These timed tests were carried out on the most common cables with a metal protection and an outer jacket. The preparation times for cables without these elements can be easily deduced from the timing of each step.











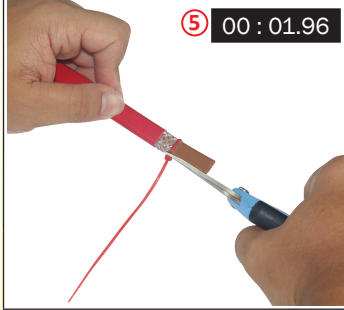

1		Serial cable with metal braid and outer jacket			
With traditional electrician tools		With specialized tools			
① 00 : 06.09		② 01 : 07.32		① 00 : 03.28	
③ 00 : 06.93		④ 00 : 04.95		③ 00 : 06.93	
⑤ 00 : 06.93		①+②+③+④+⑤ 01 : 29.68		⑤ 00 : 04.39	
		①+②+③+④+⑤ 01 : 24.15			
Time reduction: 6 %					

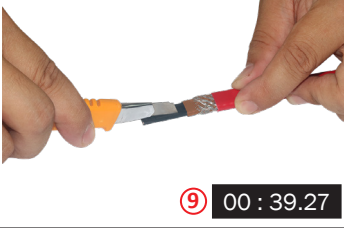
2		Self-regulating cable with metal braid and outer jacket With metal braid trimming			
With traditional electrician tools		With specialized tools			
① 00 : 15.18		② 00 : 06.38		① 00 : 04.86	
③ 00 : 04.60		④ 00 : 33.62		② 00 : 06.95	
⑤ 00 : 23.56		⑥ 00 : 24.43		③ 00 : 15.65	
		④ 00 : 10.05			



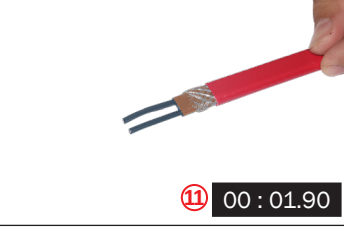
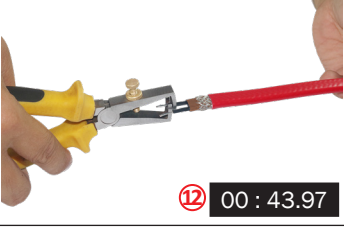

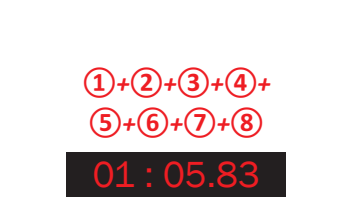



* These exclusive tools are available in accessories section

Technical introduction

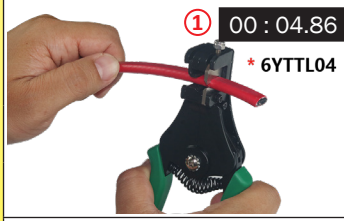

With traditional electrician tools		With specialized tools	
 ⑦ 00 : 16.25	 ⑧ 00 : 17.55	 ⑤ 00 : 01.96	 ⑥ 00 : 08.74
 ⑨ 00 : 39.27	 ⑩ 00 : 16.24	 ⑦ 00 : 10.09	 ⑧ 00 : 07.53
 ⑪ 00 : 01.90	 ⑫ 00 : 43.97	 ⑦ 00 : 10.09	 ⑧ 00 : 07.53
 ①+②+③+④+⑤+⑥+ ⑦+⑧+⑨+⑩+⑪+⑫ 04 : 03.05		 ①+②+③+④+ ⑤+⑥+⑦+⑧ 01 : 05.83	
Time reduction: 75%			

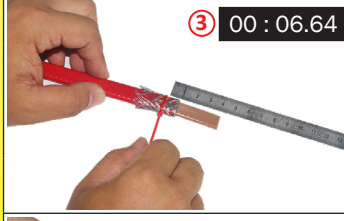
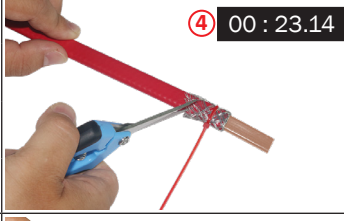
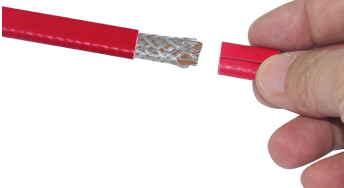
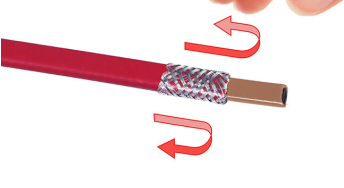
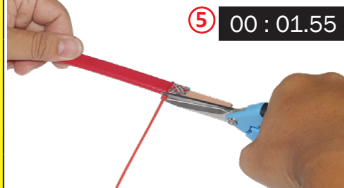
3 Self-regulating cable with metal braid and outer jacket With rolling up of the metal braid

With traditional electrician tools		With specialized tools	
 ① 00 : 07.46	 ② 00 : 06.86	 ① 00 : 04.86	 ② 00 : 12.86
 ③ 00 : 02.47	 ④ 00 : 13.72	 ③ 00 : 06.64	 ④ 00 : 23.14
 ③ 00 : 02.47	 ④ 00 : 13.72	 ⑤ 00 : 01.55	 ⑥ 00 : 09.93

* These exclusive tools are available in accessories section

Because of permanent improvement of our products, drawings, descriptions, features used on these data sheets are for guidance only and can be modified without prior advice

Technical introduction



Because of permanent improvement of our products, drawings, descriptions, features used on these data sheets are for guidance only and can be modified without prior advice

With traditional electrician tools		With specialized tools	
<p>⑤ 00 : 44.11</p>	<p>⑥ 00 : 44.25</p>	<p>⑦ 00 : 07.89 * 6YTTL05</p>	<p>⑧ 00 : 07.95 * 6YTTL04</p>
<p>⑦ 00 : 37.29</p>	<p>①+②+③+④+⑤+⑥+⑦ 02 : 36.16</p>	<p>①+②+③+④+ ⑤+⑥+⑦+⑧ 01 : 14.82</p>	
Time reduction: 52 %			

4 Self-regulating cable with metallic strip, earth conductor and outer jacket

With traditional electrician tools		With specialized tools	
<p>① 00 : 15.43</p>	<p>② 00 : 12.22</p>	<p>① 00 : 04.86 * 6YTTL04</p>	<p>② 00 : 02.96</p>
<p>③ 00 : 08.54</p>	<p>④ 00 : 06.12</p>	<p>③ 00 : 08.74 * 6YTTL04</p>	<p>④ 00 : 10.09 * 6YTTL05</p>
<p>⑤ 00 : 14.76</p>	<p>⑥ 00 : 12.13</p>	<p>⑤ 00 : 11.53 * 6YTTL04</p>	<p>⑥ 00 : 06.14</p>
<p>⑦ 00 : 07.64</p>	<p>⑧ 00 : 47.69</p>	<p>⑦ 00 : 07.64 * 6YTTL04</p>	<p>⑧ 00 : 06.14</p>
<p>⑨ 00 : 22.32</p>	<p>⑩ 00 : 06.14</p>	<p>⑨ 00 : 11.53 * 6YTTL04</p>	<p>⑩ 00 : 06.14</p>
<p>①+②+③+④+⑤+ ⑥+⑦+⑧+⑨+⑩ 02 : 32.99</p>		<p>①+②+③+④+⑤ 00 : 38.18</p>	
Time reduction: 59 %			

* These exclusive tools are available in accessories section



5

Constant power cable with metal braid and outer jacket

With traditional electrician tools		With specialized tools	
① 00 : 23.48 	② 01 : 08.19 	① 00 : 06.73 	② 01 : 08.19
③ 00 : 07.03 	④ 00 : 27.30 	③ 00 : 07.03 	④ 00 : 05.25
⑤ 00 : 15.08 	⑥ 00 : 02.05 	⑤ 00 : 04.88 	⑥ 00 : 02.05
⑦ 00 : 04.23 	①+②+③+④+⑤+⑥+⑦ 02 : 27.36	⑦ 00 : 04.23 	①+②+③+④+⑤+⑥+⑦ 01 : 38.36
Time reduction: 33 %			

Because of permanent improvement of our products, drawings, descriptions, features used on these data sheets are for guidance only and can be modified without prior advice

* These exclusive tools are available in accessories section



Because of permanent improvement of our products, drawings, descriptions, features used on these data sheets are for guidance only and can be modified without prior advice

List of references



Because of permanent improvement of our products, drawings, descriptions, features used on these data sheets are for guidance only and can be modified without prior advice

List of references



Because of permanent improvement of our products, drawings, descriptions, features used on these data sheets are for guidance only and can be modified without prior advice

References	References	References	References	References
2DNAP6FA	6YTBA015503040H0	6YTDKBBPE3001062	6YTNL01N09800045	6YTPFM24S100140S
2DNAP6FB	6YTBA015503040P0	6YTDKBBPU2001061	6YTNL02N08620032	6YTPFM24SF35110N
2DNAP6FE	6YTBTO1250304B25	6YTDKBBPU2001062	6YTNL03N13006075	6YTPFM24SF35110S
2DNAP6FF	6YTBTO1250304BE5	6YTDKBBPU2001063	6YTNL04N10005546	6YTPFM24SF60095N
4911EJ01006CUSV0	6YTBTO1250SGCB25	6YTDKBBPU2001064	6YTNM01N08504545	6YTPFM24SF60095S
49COTPPP8LLLA4	6YTBTO1250SGCBE5	6YTDKBBPU3001061	6YTNM02N08203032	6YTPFM24SF60130N
49COTPPP8LLLB4	6YTBTO2025304C25	6YTDKBBPU3001062	6YTNM03N11004075	6YTPFM24SF60130S
49COTPPP8LLLC4	6YTBTO2025304CK0	6YTDKBBPU3001063	6YTNM04N13508246	6YTPFM24SF92142N
49COTPPP8LLLD4	6YTBTO2025304D25	6YTDKBBPU3001064	6YTPEM20S040080N	6YTPFM24SF92142S
49COTPPP8LLLE1	6YTBTO2025304DU0	6YTEW16S0F5010	6YTPEM20S040080S	6YTPFM24SSRF000N
49COTPPP8LLLF1	6YTBTO2025SGCC25	6YTEW26S0F50110	6YTPEM20S080120N	6YTPFM24SSRF000S
49COTPPP8LLLG1	6YTBTO2025SGCCK0	6YTEW36S0F50120	6YTPEM20S080120S	6YTPGM20S040080N
49COTPPP8LLLH1	6YTBTO2025SGCDU0	6YTEW46S0F60130	6YTPEM20SF60130N	6YTPGM20S040080S
49COTPPP8LLLJ3	6YTBTO2025SGD25	6YTEW56SOR60000	6YTPEM20SF60130S	6YTPGM20S080120N
49COTPPP8LLLK3	6YTCORC009011006	6YTEW66SOR70000	6YTPEM20SSRF000N	6YTPGM20S080120S
49COTPPP8LLLL2	6YTCORC019033016	6YTJEM20S080120S	6YTPEM20SSRF000S	6YTPGM20SF60130N
49COTPPP8LLLM2	6YTCORC023036016	6YTJEM20SF60130S	6YTPEM24S060080N	6YTPGM20SF60130S
49COTPPP8LLLN2	6YTDKAAPE2001060	6YTM2000ELH062A	6YTPEM24S060080S	6YTPGM20SSRF000N
49COTPPP8LLLP2	6YTDKAAPE3001060	6YTNB01N120040A5	6YTPEM24S080120N	6YTPGM20SSRF000S
49COTPPP8LLLQ2	6YTDKAAPU2001060	6YTNB02N125055A2	6YTPEM24S080120S	6YTPGM24S060080N
49COTPPP8LLLR2	6YTDKAAPU3001060	6YTNB03N116046A0	6YTPEM24S100140N	6YTPGM24S060080S
49JBDJ01006KFR18	6YTDKABPE2001060	6YTNB04N110040A1	6YTPEM24S100140S	6YTPGM24S080120N
49JBDJ01006KFR28	6YTDKABPE3001060	6YTNB05N130048A2	6YTPEM24SF35110N	6YTPGM24S080120S
49JBDJ01006KFR38	6YTDKABPU2001060	6YTNB06N110038A2	6YTPEM24SF35110S	6YTPGM24S100140N
49JBDJ01006KFRF8	6YTDKABPU3001060	6YTNE07N09800045	6YTPEM24SF60095N	6YTPGM24S100140S
66JGN08075164	6YTDKBAPE2001061	6YTNE08N08620032	6YTPEM24SF60095S	6YTPGM24SF35110N
66JGN080P5185	6YTDKBAPE2001062	6YTNE09N13006075	6YTPEM24SF60130N	6YTPGM24SF35110S
66JGN10075164	6YTDKBAPE2001063	6YTNE10N10005546	6YTPEM24SF60130S	6YTPGM24SF60095N
66JGN120P5185	6YTDKBAPE2001064	6YTNE11N12004275	6YTPEM24SF92142N	6YTPGM24SF60095S
66JGN140P5185	6YTDKBAPE3001061	6YTNE12N14004275	6YTPEM24SF92142S	6YTPGM24SF60130N
66JGNF6075164130	6YTDKBAPE3001062	6YTNE13N06804675	6YTPEM24SSRF000N	6YTPGM24SF60130S
66JGT08075164	6YTDKBAPE3001063	6YTNE14N09203575	6YTPEM24SSRF000S	6YTPGM24SF92142N
66JGT080P5185	6YTDKBAPE3001064	6YTNE15N12206366	6YTPFM20S040080N	6YTPGM24SF92142S
66JGT10075164	6YTDKBAPU2001061	6YTNE16N16007566	6YTPFM20S040080S	6YTPGM24SSRF000N
66JGT120P5185	6YTDKBAPU2001062	6YTNJ01N08504550	6YTPFM20S080120N	6YTPGM24SSRF000S
66JGT140P5185	6YTDKBAPU2001063	6YTNJ02N08203053	6YTPFM20S080120S	6YTPIM20S040080N
66JGTF6075164130	6YTDKBAPU2001064	6YTNJ03N11004063	6YTPFM20SF60130N	6YTPIM20S040080S
66JPN18518265	6YTDKBAPU3001061	6YTNJ04N13508265	6YTPFM20SF60130S	6YTPIM20S080120N
66JPT18518265	6YTDKBAPU3001062	6YTNJ05N00200027	6YTPFM20SSRF000N	6YTPIM20S080120S
66JPT22518300	6YTDKBAPU3001063	6YTNJ06N00500040	6YTPFM20SSRF000S	6YTPIM20SF60130N
66JRN18520225	6YTDKBAPU3001064	6YTNJ07N00800050	6YTPFM24S060080N	6YTPIM20SF60130S
66JRN22520245	6YTDKBBPE2001061	6YTNK1	6YTPFM24S060080S	6YTPIM20SSRF000N
66NCM20545H25	6YTDKBBPE2001062	6YTNK2	6YTPFM24S080120N	6YTPIM20SSRF000S
66NCM24560H30	6YTDKBBPE2001063	6YTNK3	6YTPFM24S080120S	6YTPIM24S060080N
66NDM20545H25	6YTDKBBPE2001064	6YTNK4	6YTPFM24S100140N	6YTPIM24S060080S

List of references



References	References	References	References	References
6YTPIM24S080120N	6YTTL04A3	TPJBD150A03022D6	Y280PFFF000000S0	Y8WRC02100200AUZ
6YTPIM24S080120S	6YTTL04B1	TPJBD150A10022D6	Y280PSSS000000S0	Y8WRC02100300AUZ
6YTPIM24S100140N	6YTTL04B10	TPJBD150A20022D6	Y29BGYS300P6930	Y8WRD02100000AUX
6YTPIM24S100140S	6YTTL04B11	TPJBD150A30022D6	Y29CGYS316P6930	Y8WRD02100000AUY
6YTPIM24SF35110N	6YTTL04B2	TSJBD150A0302BK6	Y29EGYS326P6930	Y8WRD02100100AUZ
6YTPIM24SF35110S	6YTTL04B3	TSJBD150A1002BK6	Y29DC6S300P6930	Y8WRD02100200AUZ
6YTPIM24SF60095N	6YTTL04B4	TSJBD150A2002BK6	Y29FC6S316P6930	Y8WRD02100300AUZ
6YTPIM24SF60095S	6YTTL04B5	TSJBD150A3002BK6	Y29BGYT300P6930	Y8WRE02100000AUX
6YTPIM24SF60130N	6YTTL04B6	TSR50030I0200BK6	Y29CGYT316P6930	Y8WRE02100000AUY
6YTPIM24SF60130S	6YTTL04B7	TSR50030I0500BK6	Y29EGYT326P6930	Y8WRE02100100AUZ
6YTPIM24SF92142N	6YTTL04B8	TSR50030I1000BK6	Y29DC6T300P6930	Y8WRE02100200AUZ
6YTPIM24SF92142S	6YTTL04B9	TSR50030I2000BK6	Y29FC6T316P6930	Y8WRE02100300AUZ
6YTPIM24SSRF000N	6YTTL05A	TSR50030I3000BK6	Y29BGYS300P6DNO	Y8WRF02100000AUX
6YTPIM24SSRF000S	6YTTL05B	Y0D8KD104040QB3J	Y29CGYS316P6DNO	Y8WRF02100000AUY
6YTPJM20S040080N	6YTTL05C	Y0D9KD104040QB3J	Y29EGYS326P6DNO	Y8WRF02100100AUZ
6YTPJM20S040080S	6YTTL05D	Y1A2PN6F204040AJ	Y29DC6S300P6DNO	Y8WRF02100200AUZ
6YTPJM20S080120N	9UWTTPPPP8LLLA4	Y1A2PN6F235035AJ	Y29FC6S316P6DNO	Y8WRF02100300AUZ
6YTPJM20SF60130N	9UWTTPPPP8LLLB4	Y1A8G4040AQ30001J	Y29BGYT300P6DNO	Y8WRM02100000AUX
6YTPJM20SSRF000N	9UWTTPPPP8LLLC4	Y1B2PN6F204040AJ	Y29CGYT316P6DNO	Y8WRM02100000AUY
6YTPJM20SSRF000S	9UWTTPPPP8LLLD4	Y1B2PN6F235035AJ	Y29EGYT326P6DNO	Y8WRM02100100AUZ
6YTPJM24SF35110N	9UWTTPPPP8LLLE1	Y1B8G4040AQ30001J	Y29DC6T300P6DNO	Y8WRM02100200AUZ
6YTPJM24SF35110S	9UWTTPPPP8LLLF1	Y22D9J01006USUS0	Y29FC6T316P6DNO	Y8WRM02100300AUZ
6YTPJM24SF60095N	9UWTTPPPP8LLLG1	Y240MW	Y501N2N500001	Y8WRR02100000AUX
6YTPJM24SF60095S	9UWTTPPPP8LLLH1	Y240RF	Y501N7N800001	Y8WRR02100000AUY
6YTPJM24SF60130N	9UWTTPPPP8LLLJ3	Y240SS	Y501S2S500001	Y8WRR02100100AUZ
6YTPJM24SF60130S	9UWTTPPPP8LLLK3	Y240XX	Y501S7S800001	Y8WRR02100200AUZ
6YTPJM24SF92142N	9UWTTPPPP8LLLL2	Y250FPP	Y502N5N500001	Y8WRR02100300AUZ
6YTPJM24SF92142S	9UWTTPPPP8LLLLM2	Y250NKK	Y502N8N800001	YF62NC000100000J
6YTPJM24SSRF000N	9UWTTPPPP8LLLLN2	Y250SPP	Y502S5S500001	YF62NC040400000J
6YTPJM24SSRF000S	9UWTTPPPP8LLLLP2	Y250XKK	Y502S8S800001	YF62NC350350000J
6YTPPCP9801B32	9UWTTPPPP8LLLLQ2	Y260KNN0000000S0	Y514N2N5N5N51	YF7GNC04040023ZJ
6YTPPCP9802B32	9UWTTPPPP8LLLLR2	Y260KXX0000000S0	Y514N7N8N8N8N81	
6YTPPCP9811B32	TJJBD150A03022D6	Y260PFF	Y8WHQ02100000AUX	
6YTPPCP9812B32	TJJBD150A10022D6	Y260PSS0000000S0	Y8WHQ02100000AUY	
6YTPPCP9821B32	TJJBD150A20022D6	Y261KNN610304300	Y8WHQ02100100AUZ	
6YTPPCP9822B32	TJJBD150A30022D6	Y261KXX610304300	Y8WHQ02100200AUZ	
6YTQS2420	TNJBD150A03022F6	Y261PFF610304300	Y8WHQ02100300AUZ	
6YTQS2620	TNJBD150A10022F6	Y261PSS610304300	Y8WJU021D0000AUX	
6YTPTE440	TNJBD150A20022F6	Y261SS06103004300	Y8WJU021D0000AUY	
6YTPTE499	TNJBD150A30022F6	Y270KNN0000000S0	Y8WJU021D0100AUZ	
6YTQTW46	TNR60030C02001F4	Y270KXX0000000S0	Y8WJU021D0200AUZ	
6YTTL03	TNR60030C05001F4	Y270PFF0000000S0	Y8WJU021D0300AUZ	
6YTTL04	TNR60030C10001F4	Y270PSS0000000S0	Y8WRC02100000AUX	
6YTTL04A1	TNR60030C20001F4	Y280KNNN000000S0	Y8WRC02100000AUY	
6YTTL04A2	TNR60030C30001F4	Y280KXXX000000S0	Y8WRC02100100AUZ	

Because of permanent improvement of our products, drawings, descriptions, features used on these data sheets are for guidance only and can be modified without prior advice

Update 2026/06/15



Section 4

Heat tracing connection boxes, connection on stripped conductors



The advantages of terminals with tightening on stripped conductors

- Visualization of the connection.
- No need to check the ohmic resistance of the connection to verify that it is correctly made.
 - Usable on all types of heating cables
- Each terminal, because of the use of square dented washers, can receive two conductors.

2 ways in line connection box for heat tracing cables, for traditional or self-regulating cables



Because of permanent improvement of our products, drawings, descriptions, features used on these data sheets are for guidance only and can be modified without prior advice

2 ways in line	Screw and square washer terminals	Wire gauge	Cables diameters		Type
		1~2.5mm ²			Y24

Applications

This box allows to **connect end-to-end**, on field, **with a good ingress protection (IP66)**, a round or flat heating cable to a round power cable. However, it also makes it possible to connect together two round cables or two flat cables. The internal connection terminal block is in ceramic.

Main features

Material: Polyamide 66 black, total length 93mm. Good UV resistance.

Waterproof grade: IP66

Mounting:

- Wall mounting: By 2 side lugs for 4mm diameter screws, 35mm distance.
- On pipe: By a nylon cable tie. The lower part is concave to facilitate this assembly and the oblong holes of the lugs allow the passage and holding of a cable tie.

Terminal block:

- High temperature ceramic with screw terminals with captive toothed square washers accepting bare conductors
- 3 conductors, from 1 to 2.5mm²
- Maximum permissible intensity: 16A 250V

Cable clamping: with M24 cable glands, with 70 shore NBR gaskets

- Size limits of round cables: 6 to 12,2mm
- Size limits of flat cables: from 8.7 × 3.5 to 14.2 × 9.2mm

For more information, see the catalogue page on 6YTP cable glands.

Easy assembly: It is possible to slide the ceramic terminal block out of the body to connect the cables outside of it.

Main part numbers

Part number	Seals on side A*	Seals on side B*
Y24ORF	Silicone seal for round cable dia. 12mm max.	Silicone seal for oblong cable max. size 13x6mm
Y240MW	NBR seal for round cable dia. 12mm max.	NBR seal for oblong cable max. size 13x6mm.
Y240SS	Set of silicone seals for round cables dia. max. 8, 12 and 14mm.	Set of Silicone seal for oblong cables max. size 9.5x6; 11x3.5; 13x6 and 14.2x9.2mm.
Y240XX	Set of NBR seals for round cables dia. max. 8, 12 and 14mm.	Set of NBR seal for oblong cables max. size 9.5x6; 11x3.5; 13x6 and 14.2x9.2mm.

* Silicone seals recommended for ambient temperature higher than 80°C.

2 ways in line connection box for heat tracing cables, for traditional or self-regulating cables



Stripping dimensions of round and oblong cables

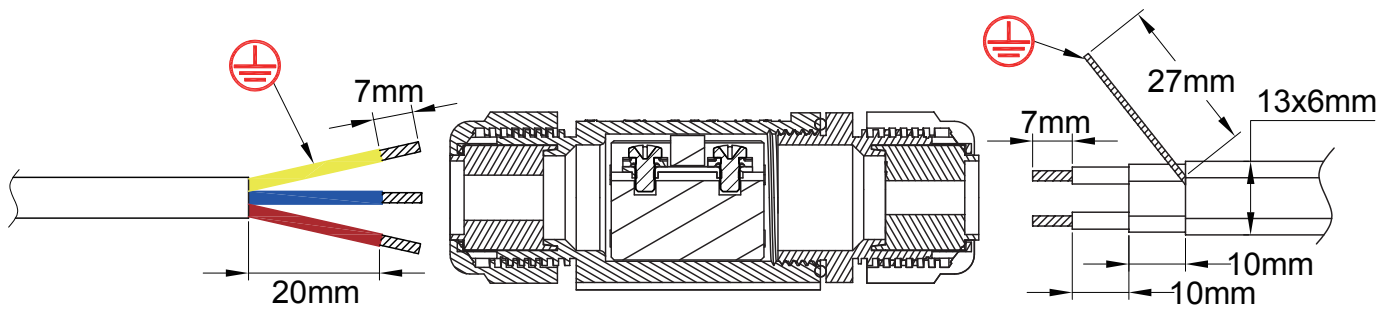

Cables assembly steps

(More details on the different methods of preparing termination for various types of cables are available in the technical introduction).

<p>1</p>	<p>2</p>
<p>3</p>	<p>4</p> <p>* 6YTTL04</p>
<p>5</p>	<p>6</p> <p>* 6YTTL04</p>
<p>1 : Pass the power supply cable through the cable gland nut, its seal and the terminal block body. Remove outside jacket and strip the conductors according to the required dimensions.</p>	<p>2 : Insert the stripped part of the conductors into the terminals and tighten with a screwdriver. Recommended tightening torque 1.2Nm</p>
<p>3 : After selecting the cable gland seal to the recommended size for the cable type, pass the heating cable through the gland nut, its seal and the body of the cable gland.</p>	<p>4 : Strip the outer jacket of the heating cable to the required length.</p>
<p>5 : Twist the metal braid to make it a round conductor.</p>	<p>6 : Strip the insulating jacket around the heating part to the required length.</p>

* These exclusive tools are available in accessories section

2 ways in line connection box for heat tracing cables, for traditional or self-regulating cables





Because of permanent improvement of our products, drawings, descriptions, features used on these data sheets are for guidance only and can be modified without prior advice

<p>7</p> <p>* 6YTTL05</p>	<p>8</p> <p>* 6YTTL04</p>
<p>7 : Cut the heating part between the two bus wires to the required length.</p>	<p>8 : Strip the two bus wires over the required length.</p>
<p>9</p>	<p>10</p>
<p>9 : If necessary, cut the stripped bus wires to length.</p>	<p>10 : Insert the bus wires into the terminals and tighten with a screwdriver. Recommended tightening torque 1.2Nm.</p>
<p>11</p>	<p>12</p>
<p>11 : Slide all of the cables and the ceramic terminal block into the body.</p>	<p>12 : Screw the cable gland into the body without turning the cables, then tighten the cable gland nut of the power cord. Maximum tightening torque 3N.m.</p>
<p>13</p>	
<p>13 : Insert the cable gland seal in the latter and then tighten the cable gland nut. Maximum tightening torque 3N.m.</p>	

* These exclusive tools are available in accessories section

3 ways in T connection box for heat tracing cables, for traditional or self-regulating cables

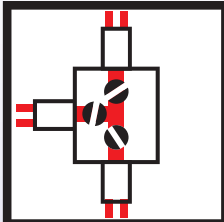
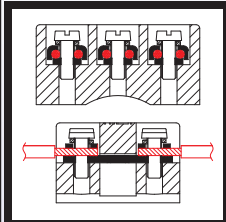
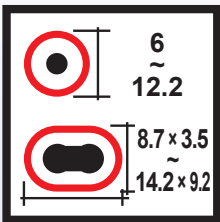

3 ways in T	Screw and saddle terminals	Wire gauge	Cables diameters		Type
		1~2.5mm ²			Y25

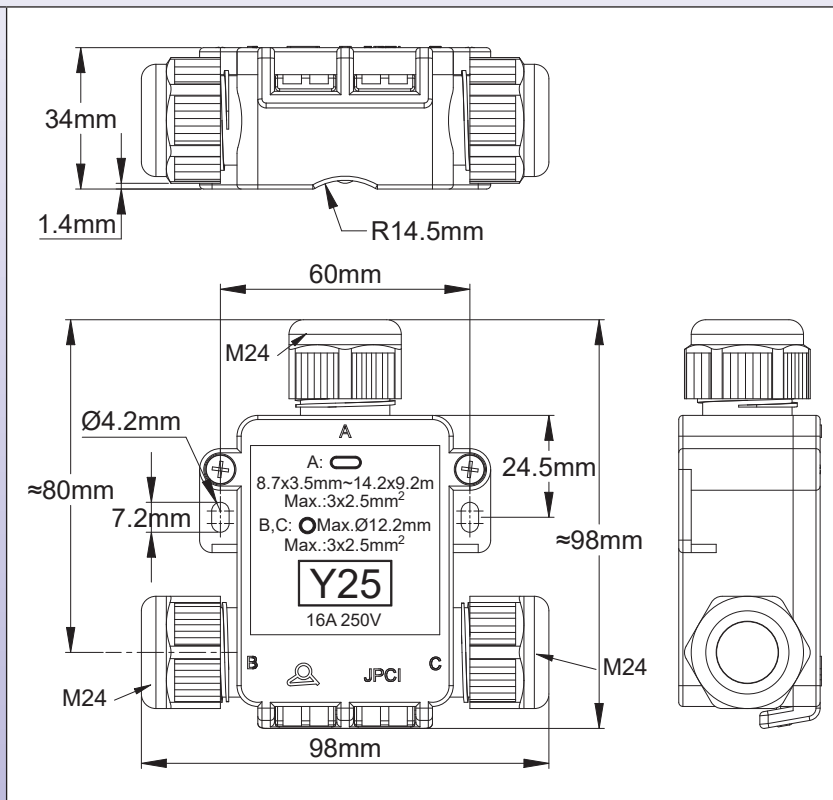

Applications

This box allows to connect, with a good ingress protection (IP66), end-to-end, on field, a round or flat heating cable to a round power cable, **and providing at the same time the continuity of the power line.** An example of this type of connection is the feeding of heated drinking troughs in stables or breeding premises. The internal connection terminal block is in ceramic.

Main features

Material: Polyamide 66 black, 98mm × 98mm × 34mm. Good UV resistance.

Waterproof grade: IP66.

Mounting:

- Wall mounting: by 2 side lugs for 4mm diameter screws, 60mm distance.
- Pipe mounting: By a nylon cable tie. The oblong holes of the lugs allow the passage and holding of a cable tie.

Terminal block:

- High temperature ceramic with screw and saddle terminals for 0.5mm² to 2.5mm² conductors
- Maximum permissible intensity: 16A 250V

Cable clamping: with M24 cable glands, with silicone gaskets

- Maximum diameter of round cables: 12.2mm on B and C output
- Size limits of flat cable on A output: from 8.7 × 3.5 to 14.2 × 9.2mm.

For more information about tightening possibilities on round and oblong cables, see the catalogue page on 6YTP cable glands.

For cables of larger dimensions or too rigid to be able to be fitted inside this model, see the connection boxes of the Y26 and Y27 series.

Easy assembly: It is possible to slide the ceramic terminal block out of the body to connect the cables outside of it.

3 ways in T connection box for heat tracing cables, for traditional or self-regulating cables



Main part numbers

Part numbers	Seals on side A*	Seals on side B*	Seals on side C*
Y250FPP	Silicone seal for oblong cable max. size 13 × 6mm	Silicone seal for round cable dia. 12.2mm max	Silicone seal for round cable dia. 12.2mm max.
Y250NKK	NBR seal for oblong cable max. size 13 × 6mm.	NBR seal for round cable dia. 12.2mm max.	NBR seal for round cable dia. 12.2mm max.
Y250SPP	Set of Silicone seal for oblong cables max. size 9.5x6; 11x3.5; 13x6 and 14.2x9.2mm.	Silicone seal for round cable dia. 12.2mm max.	Silicone seal for round cable dia. 12.2mm max.
Y250XKK	Set of NBR seals for oblong cables max. size 9.5x6; 11x3.5; 13x6 and 14.2x9.2mm.	NBR seal for round cable dia. 12.2mm max.	NBR seal for round cable dia. 12.2mm max.

* Silicone seals recommended for ambient temperature higher than 80°C

Stripping dimensions of round and oblong cables

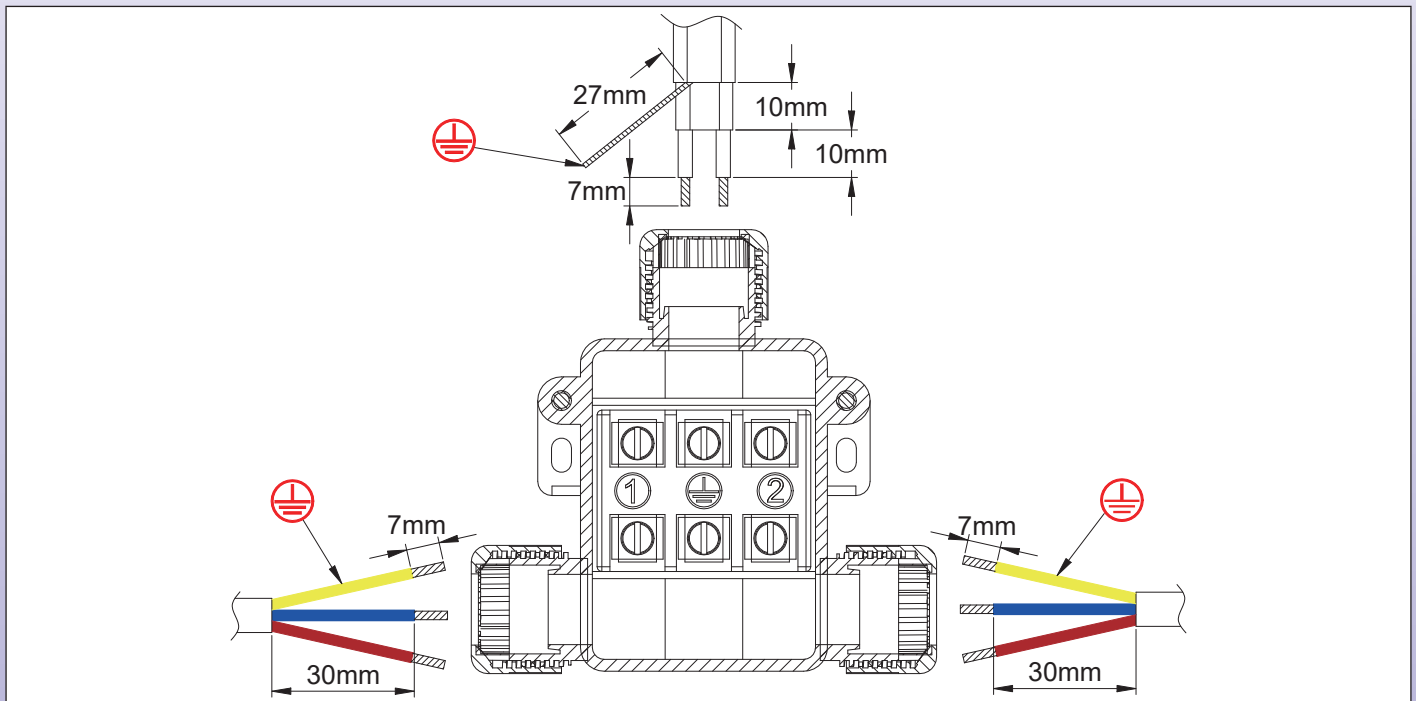

Cables assembly steps

(More details on the different methods of preparing termination for various types of cables are available in the technical introduction).

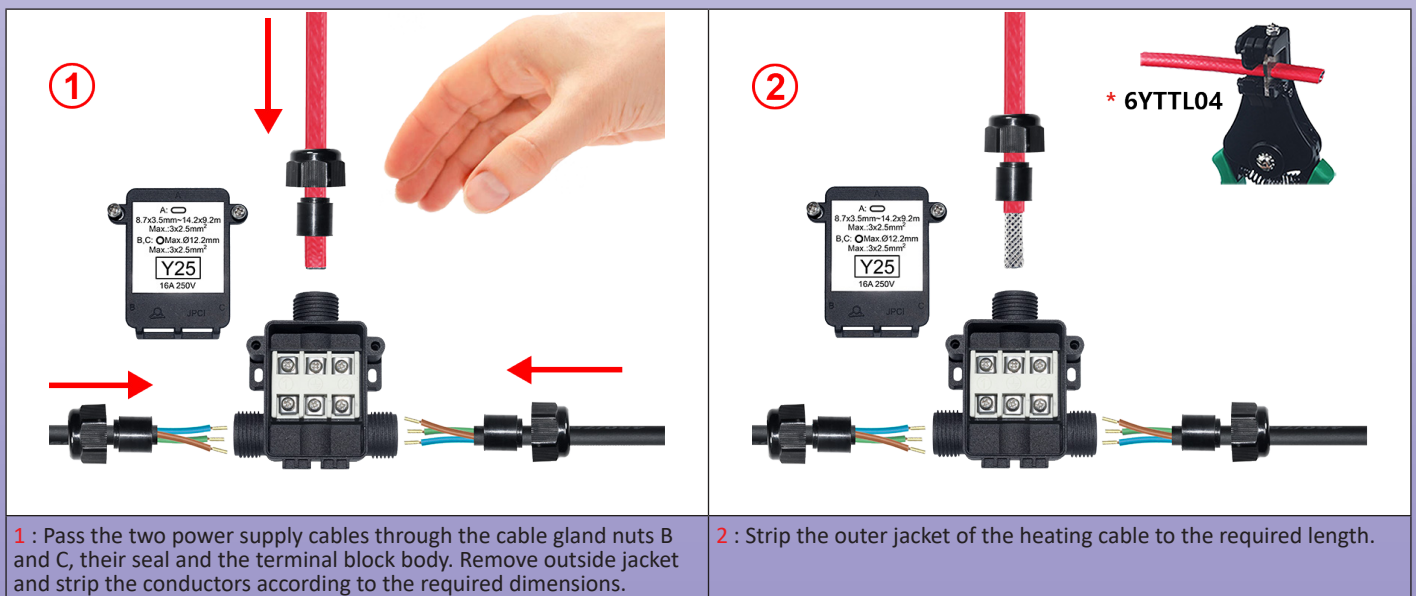

1 : Pass the two power supply cables through the cable gland nuts B and C, their seal and the terminal block body. Remove outside jacket and strip the conductors according to the required dimensions.

2 : Strip the outer jacket of the heating cable to the required length.

* These exclusive tools are available in accessories section

Because of permanent improvement of our products, drawings, descriptions, features used on these data sheets are for guidance only and can be modified without prior advice

3 ways in T connection box for heat tracing cables, for traditional or self-regulating cables



Because of permanent improvement of our products, drawings, descriptions, features used on these data sheets are for guidance only and can be modified without prior advice

<p>3 : Twist the metal braid to make it a round conductor.</p>	<p>4 : Strip the insulating jacket around the heating part to the required length.</p>
<p>5 : Cut the heating part between the two bus wires of the heating cable to the required length.</p>	<p>6 : Strip the two bus wires over the required length.</p>
<p>7 : If necessary, cut the stripped bus wires to length.</p>	<p>8 : Insert the stripped part of the heating cable conductors into the terminals and tighten with a screwdriver. Recommended tightening torque 1.2Nm.</p>

* These exclusive tools are available in accessories section

3 ways in T connection box for heat tracing cables, for traditional or self-regulating cables



Because of permanent improvement of our products, drawings, descriptions, features used on these data sheets are for guidance only and can be modified without prior advice

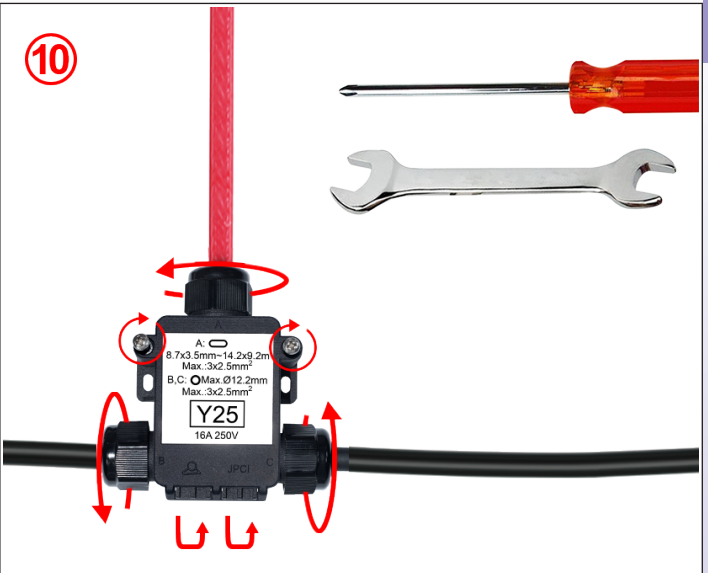
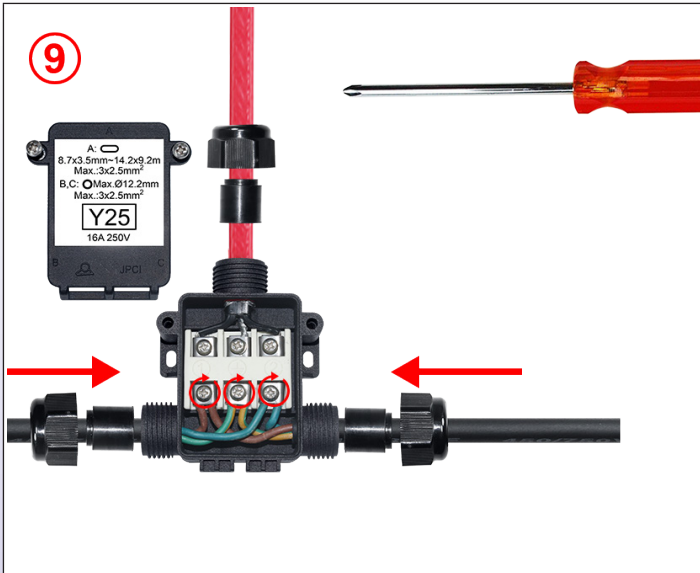

9 : Insert the stripped part of the power supply conductors into the terminals and tighten with a screwdriver. 2 conductors inside each terminal, on each side of the saddle. Recommended tightening torque 1.2Nm.

10 : Screw the cable gland nuts on the body **without turning the cables**. Maximum tightening torque 3N.m.



3 parallel ways connection box for heat tracing cables, without thermostat



Because of permanent improvement of our products, drawings, descriptions, features used on these data sheets are for guidance only and can be modified without prior advice

3 parallel ways	Screw and square washer terminals	Wire gauge	Cables diameters		Type
		1~2.5mm ²			Y260

Wall mounting

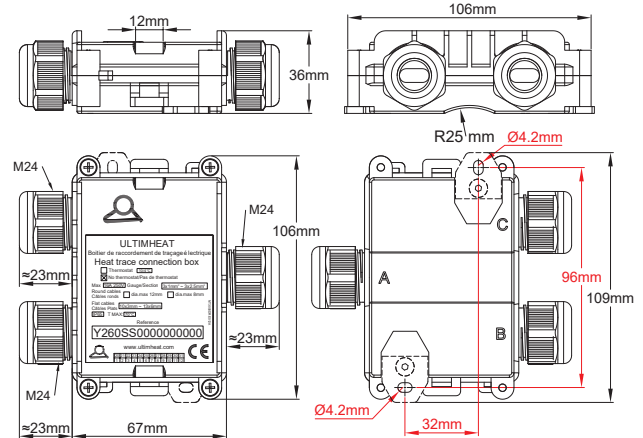

Mounting on pipe with a distant stainless steel mounting bracket

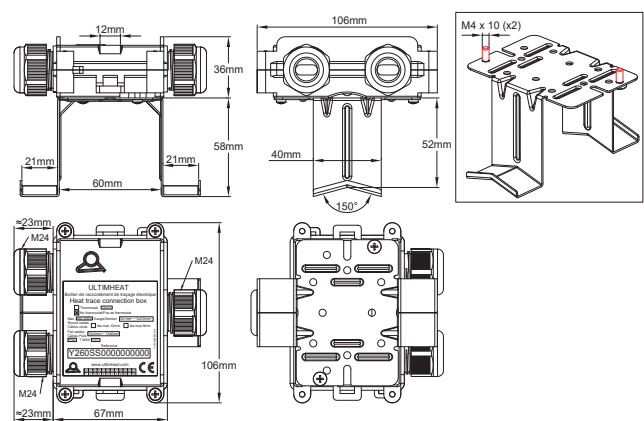

Example of mounting on pipe surface with nylon cable ties



Example of mounting on pipe with a distant stainless steel mounting bracket 6YTQT



3 parallel ways connection box for heat tracing cables, without thermostat



Applications

This box allows to connect, with a good IP65 ingress protection, 2 rounds or flat heating cable to a round power cable or providing at the same time the continuity of the power line between many connection boxes.

It can be mounted on a flat surface, or on a pipe.

Terminals positions provide easy access, wiring is simple, including for braided heating cables.

Compatible with all types of flexible heating wires, round or flat.

Main features

Material: Polyamide 66 black, 90mm × 67mm × 36mm (Cable glands not included). Excellent UV resistance.

Waterproof grade: IP65

Mounting: 2 removable wall mounting bracket, holes distance 96mm. Pipe mounting with cable tie also possible, by using the 2 rings located on the side of the box

Terminals:

- Screw terminals with captive toothed square washers accepting rigid or flexible conductors.
- The mechanical tightening of the cable is ensured by a screwed metal saddle, usable on round or flat cable.

This patented saddle also ensures the earthing of the metal braid of the heating cables.

- Wire gauge: 3 × 1mm² to 3 × 2.5mm²
- Maximum permissible intensity: 16A 250V

Cables outlet: with M24 cable glands, with 70 shore NBR gaskets (Silicone is available on request).

- Maximum diameter of round cables: 8; 12mm depending on the gaskets installed.

- Limit sizes of oblong cables:

- From 8 × 5 to 9.5 × 6mm
- From 9.5 × 2.5 to 11 × 3.5mm
- From 11 × 4 to 13 × 6mm
- From 12.5 × 8 to 14.2 × 9.2mm

For more information about tightening possibilities on round and oblong cables, see the catalogue page on 6YTP cable glands.

Safety sealing: supplied with 5 red plastic ties for use in the sealing holes

Easy assembly: Assembly is made with full access to terminals when cover is removed. Mounting on wall or pipe can be made with cover removed or cover assembled.

Accessories: Stainless steel bracket for mounting distant from the pipe, see accessories page 6YTQT.

Options: Model for 3 heating wires without power supply cable and model for one heating wire and 2 power supply cables.

Consult us for parts numbers of simplified models with only one dimension of cable gland gasket for round wire and flat wires, customized label, and specific set of accessories for pipe mounting (OEM versions).

Main part numbers

Part numbers	Seals on side A*	Seals on side B*	Seals on side C*
Y260PFF	Silicone seal for round cable dia. 12.2mm max.	Silicone seal for oblong cable max. size 13 × 6mm.	Silicone seal for oblong cable max. size 13 × 6mm.
Y260KNN0000000S0	NBR seal for round cable dia. 12.2mm max.	NBR seal for oblong cable max. size 13 × 6mm	NBR seal for oblong cable max. size 13 × 6mm.
Y260PSS0000000S0	Silicone seal for round cable dia. 12.2mm max.	Set of Silicone seal for oblong cables max. size 9.5 × 6; 11 × 3.5; 13 × 6 and 14.2 × 9.2mm.	Set of Silicone seal for oblong cables max. size 9.5 × 6; 11 × 3.5; 13 × 6 and 14.2 × 9.2mm.
Y260KXX0000000S0	NBR seal for round cable dia. 12.2mm max.	Set of NBR seals for oblong cables max. size 9.5 × 6; 11 × 3.5; 13 × 6 and 14.2 × 9.2mm.	Set of NBR seals for oblong cables max. size 9.5 × 6; 11 × 3.5; 13 × 6 and 14.2 × 9.2mm.

* Silicone seals recommended for ambient temperature higher than 80°C.

3 parallel ways connection box for heat tracing cables, without thermostat



Stripping dimensions of round and oblong cables

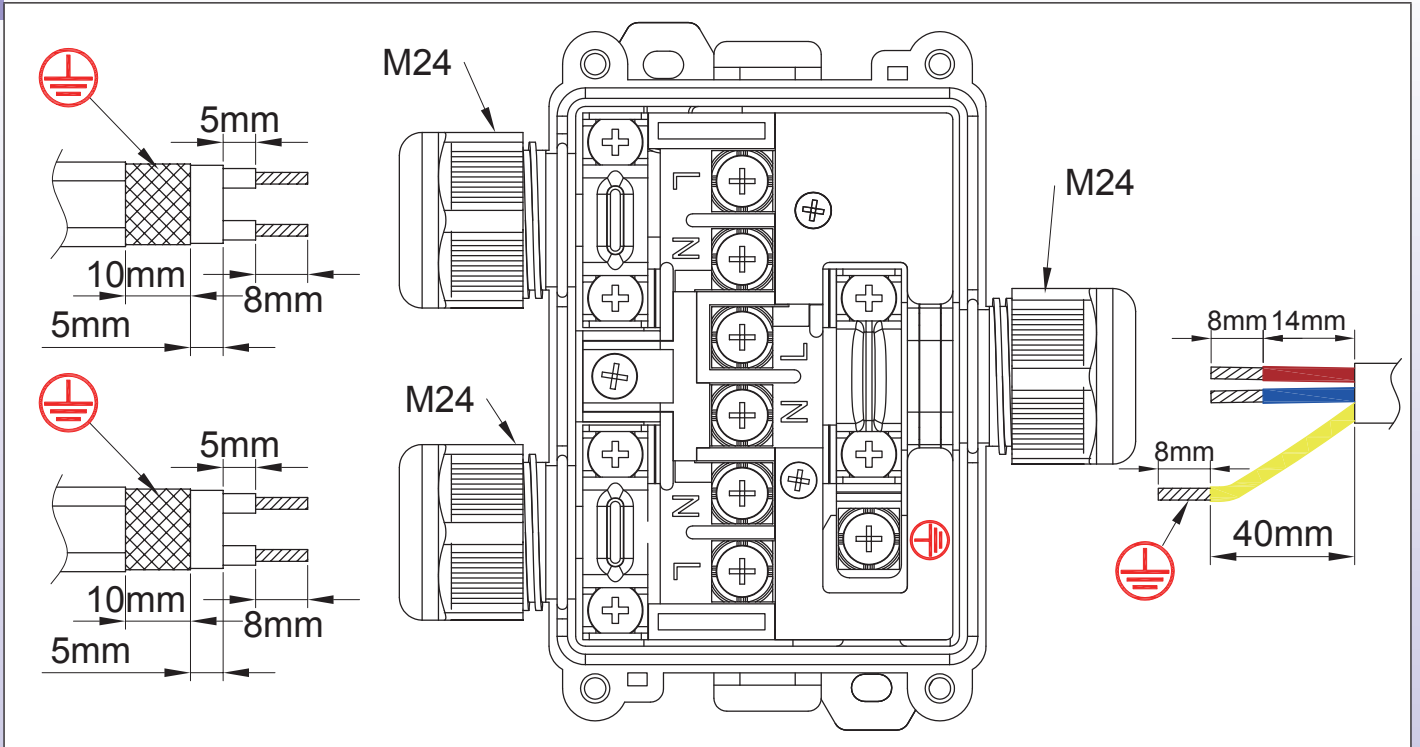

Self-regulating cables assembly steps

(More details on the different methods of preparing termination for various types of cables are available in the technical introduction)

<p>1</p>	<p>2</p>
<p>1 : After selecting the cable gland seal to the recommended size for the cable type, pass the heating cable through the gland nut and its seal.</p>	<p>2 : Strip the outer jacket of the heating cable to the required length.</p>
<p>3</p>	<p>4</p>
<p>3 : Cut the braid to the requested size.</p>	<p>4 : Strip the insulating jacket around the heating part to the required length.</p>



* These exclusive tools are available in accessories section

Because of permanent improvement of our products, drawings, descriptions, features used on these data sheets are for guidance only and can be modified without prior advice

3 parallel ways connection box for heat tracing cables, without thermostat

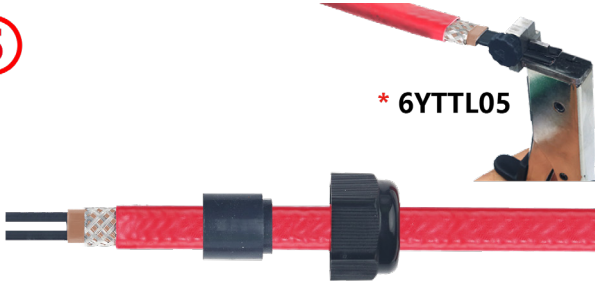
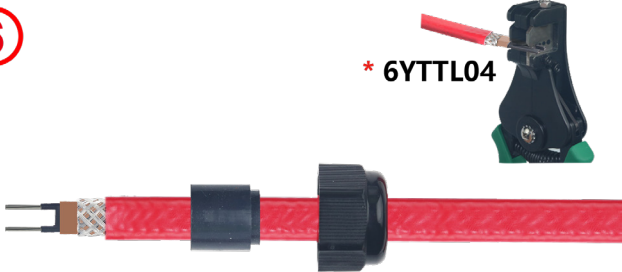
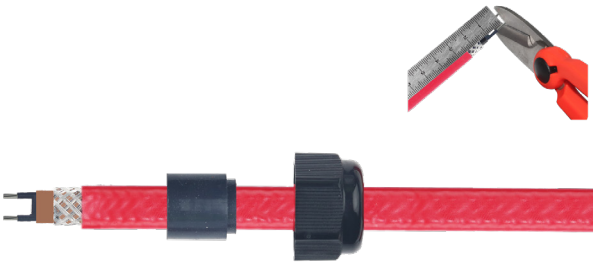
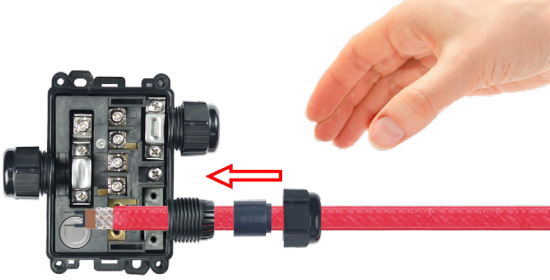

Because of permanent improvement of our products, drawings, descriptions, features used on these data sheets are for guidance only and can be modified without prior advice

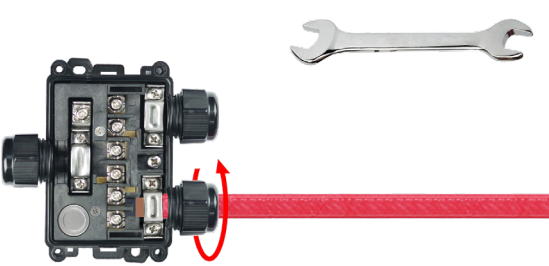
<p>5</p>  <p>* 6YTTL05</p>	<p>6</p>  <p>* 6YTTL04</p>
<p>5 : Cut the heating part between the two bus wires to the required length</p>	<p>6 : Strip the two bus wires over the required length.</p>
<p>7</p> 	<p>8</p> 
<p>7 : If necessary, cut the stripped bus wires to length.</p>	<p>8 : Unscrew and remove the saddle, unscrew and remove the terminal screws if necessary, then pass the cable through the cable gland.</p>
<p>9</p> 	<p>10</p> 
<p>9 : Put the bus wire and the braid at the place they will be tightened. Tighten the terminal block screws on the bus wires. Recommended torque 1.2 Nm</p>	<p>10 : Replace the saddle and tighten it on the metal braid. Recommended torque 1.2 Nm.</p>
<p>11</p> 	
<p>11 : Slide the flat cable gasket into the cable gland and tighten the nut. Maximum torque 3Nm. Connect any other cables and close the lid.</p>	

* These exclusive tools are available in accessories section

3 parallel ways connection box for heat tracing cables, without thermostat



Round cable assembly steps

①

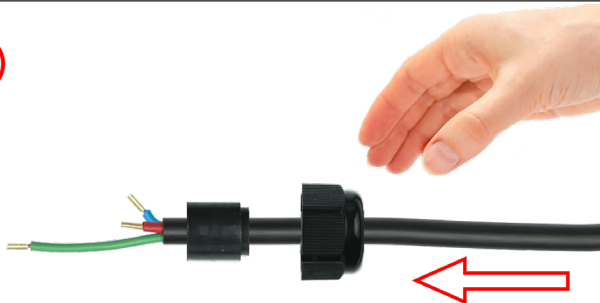

1 : Remove outer insulation on round cable as requested by drawing. Eventually, crimp cable shoes. Slide the cable gland nut on the cable. Select the compatible diameter gasket and slide it on the cable.

②

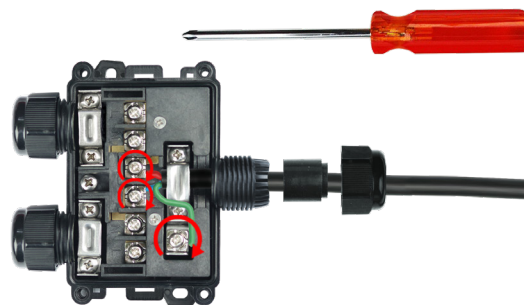

2 : Put the neutral, line and ground wires inside the screw terminals and tighten them. Recommended torque 1.2 Nm.

③

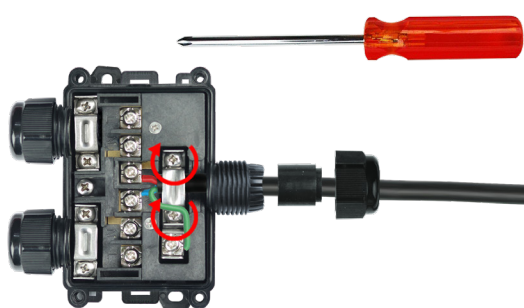

3 : Tighten the saddle screw. Recommended torque 1.6 Nm.

④

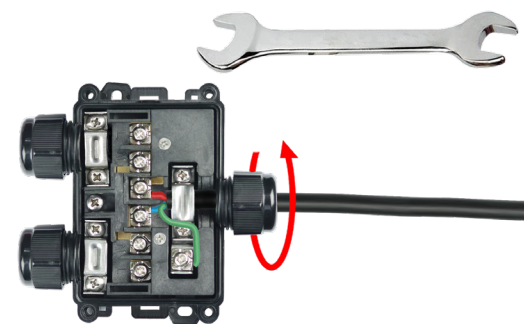

4 : Slide the round cable seal into the cable gland and tighten the nut. Maximum torque 3N.m.

Because of permanent improvement of our products, drawings, descriptions, features used on these data sheets are for guidance only and can be modified without prior advice

3 ways "Tee" connection box for heat tracing cables, without thermostat, for traditional or self-regulating cables



Because of permanent improvement of our products, drawings, descriptions, features used on these data sheets are for guidance only and can be modified without prior advice

3 parallel ways	Screw and square washer terminals	Wire gauge	Cables diameters		Type
		1~2.5mm ²			Y27

Wall mounting

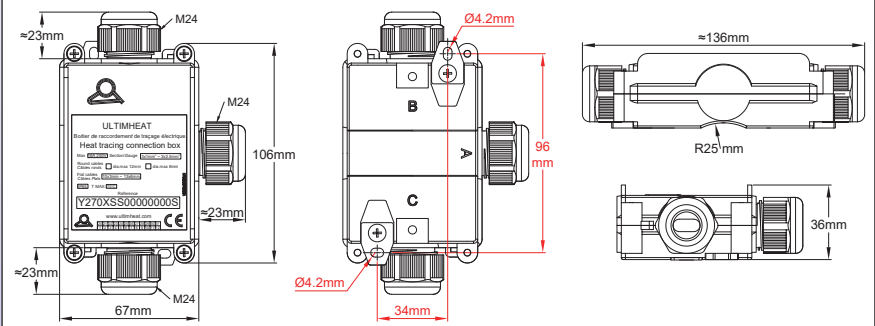

Pipe surface mounting with 2 metal tabs and nylon cable ties

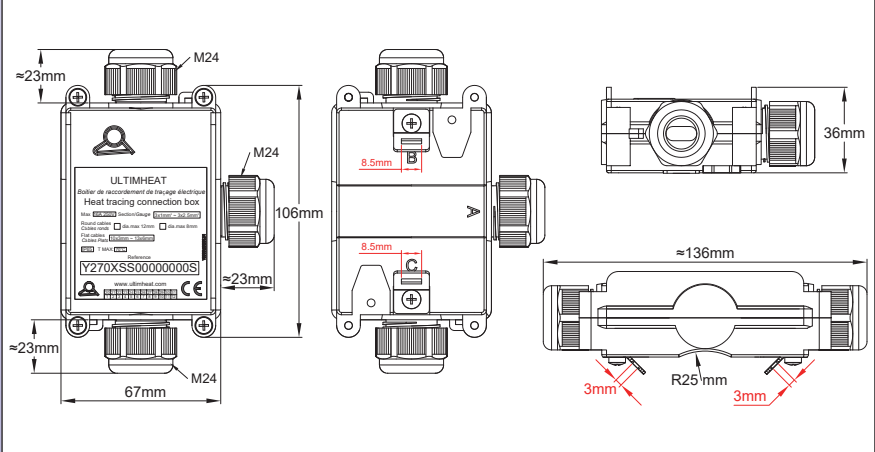

50mm offset mounting for pipes with thermal insulation (optional YTQT accessory)

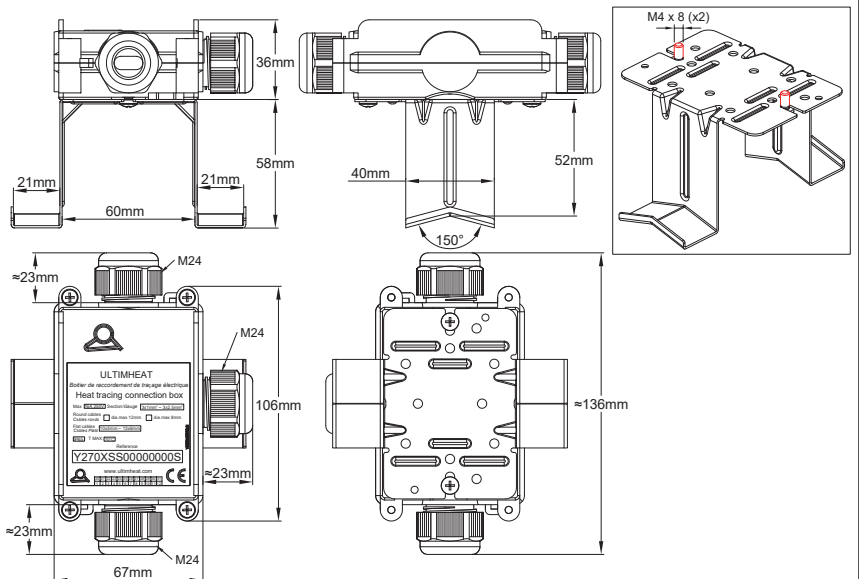

3 ways “Tee” connection box for heat tracing cables, without thermostat, for traditional or self-regulating cables



Applications

This box is used to connect **one power cable to two heating cables**, or to ensure the continuity of a power cable between several boxes, and connecting a single heating cable on each box.

It can be mounted on a flat surface, or on a pipe.

The terminal blocks are easily accessible and the **connection is simple, including for self-regulating flat cables with metallic protective braid.**

Main features

Material: Polyamide 6 black, 96mm × 67mm × 36mm (Cable glands not included). Excellent UV resistance.

Waterproof grade: IP65.

Mounting: 2 removable wall mounting bracket, holes distance 96mm. Pipe mounting with cable tie also possible with 2 small metal tabs screwed on backside.

Note: if you want to rotate the case 90° relative to the pipe, use the Y28 model with three outputs.

Terminals:

- Screw terminals with captive toothed square washers accepting stranded or rigid conductors
- The mechanical tightening of the cable is ensured by a screwed metal saddle, usable on round or flat cable.

This patented saddle also ensures the earthing of the metal braid of the heating cables.

- Wire gauge: 3 × 1mm² to 3 × 2.5mm²
- Maximum permissible intensity: 16A 250V.

Cables outlet: with M24 cable glands, with 70 shore NBR gaskets (Silicone is available on request).

- **Maximum diameter of round cables:** 8; 12mm depending on the gaskets installed.

Limit sizes of oblong cables:

- From 8 × 5 to 9.5 × 6mm
- From 9.5 × 2.5 to 11 × 3.5mm
- From 11 × 4 to 13 × 6mm
- From 12.5 × 8 to 14.2 × 9.2mm

For more information about tightening possibilities on round and oblong cables, see the catalogue page on 6YTP cable glands.

Inviolability: The case can receive one or two seals (delivered with 5 red seals)

Sealing: supplied with 5 red plastic ties for use in the sealing holes

Easy assembly: Assembly is made with full access to terminals when cover is removed. Mounting on wall or pipe can be made with cover removed or cover assembled.

Accessory: Bracket in stainless steel for offset mounting on pipe with up to 50mm insulation thickness. Can be screwed on the two M4 threads on backside. See the 6YTQT in the accessories section.

Options:

- Model for 3 heating wires without power supply cable
- Model for one heating cable and 2 power supply cables.

Consult us for parts numbers of simplified models with only one dimension of cable gland gasket for round wire and flat wires, customized label, and specific set of accessories for pipe mounting (OEM versions).

Main part numbers

(These models include 2 small metal tabs for pipe surface mounting*).

Part numbers	Seals on side A**	Seals on side B**	Seals on side C**
Y270PFF0000000SO	Silicone seal for round cable dia. 12.2mm max.	Silicone seal for oblong cable max. size 13x6mm.	Silicone seal for oblong cable max. size 13x6mm.
Y270KNN0000000SO	NBR seal for round cable dia. 12.2mm max.	NBR seal for oblong cable max. size 13x6mm.	NBR seal for oblong cable max. size 13x6mm
Y270PSS0000000SO	Silicone seal for round cable dia. 12.2mm max.	Set of Silicone seal for oblong cables max. size 9.5x6; 11x3.5; 13x6 and 14.2x9.2mm.	Set of Silicone seal for oblong cables max. size 9.5x6; 11x3.5; 13x6 and 14.2x9.2mm.
Y270KXX0000000SO	NBR seal for round cable dia. 12.2mm max.	Set of NBR seals for oblong cables max. size 9.5x6; 11x3.5; 13x6 and 14.2x9.2mm.	Set of NBR seals for oblong cables max. size 9.5x6; 11x3.5; 13x6 and 14.2x9.2mm.

* Models without the 2 small tabs, replace OSO by 000 in the part number.

** Silicone seals recommended for ambient temperature higher than 80°C.

3 ways "Tee" connection box for heat tracing cables, without thermostat, for traditional or self-regulating cables



Stripping dimensions of round and oblong cables

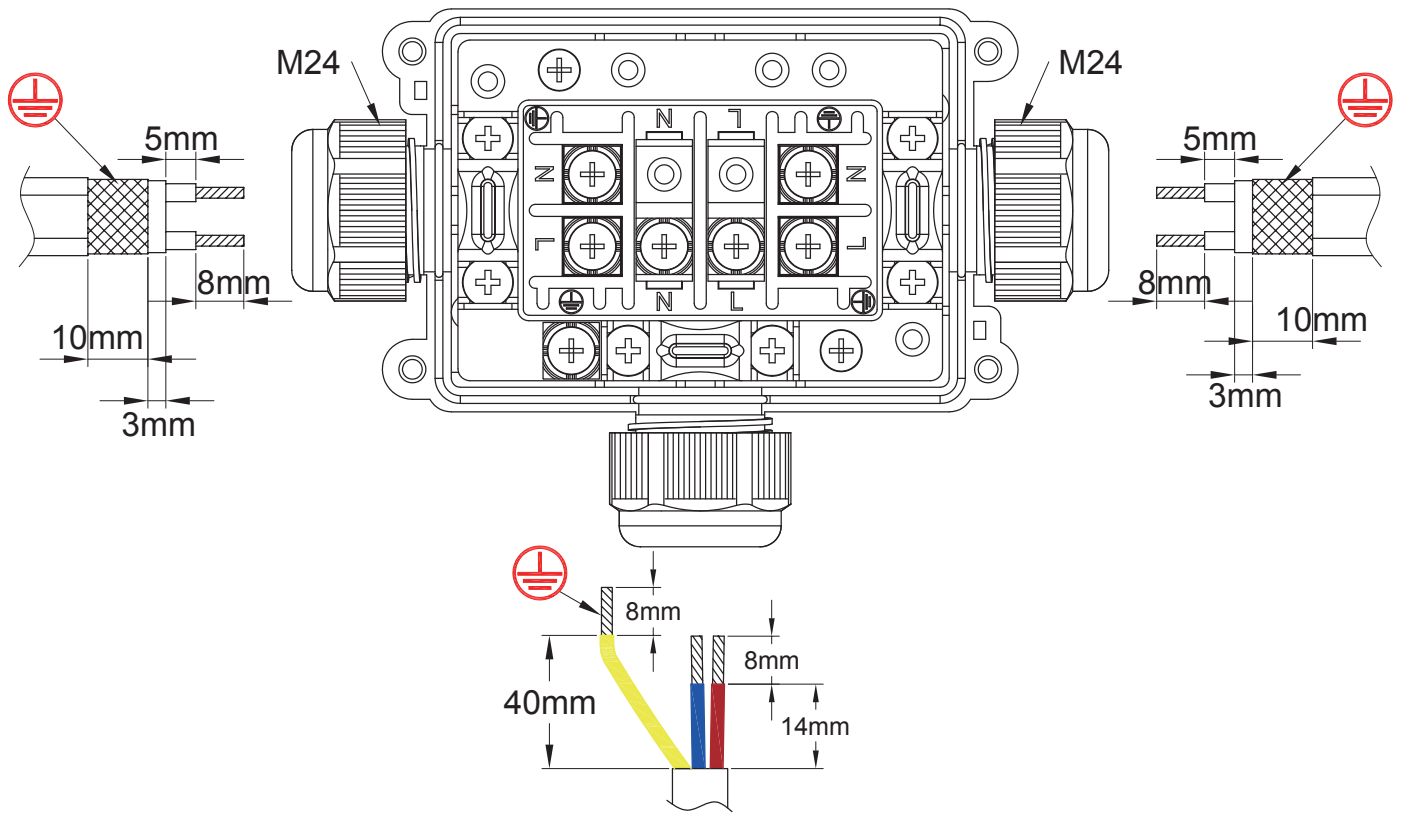

Self-regulating cables assembly steps

(More details on the different methods of preparing termination for various types of cables are available in the technical introduction).

<p>1</p>	<p>2</p>
<p>1 : After selecting the cable gland seal to the recommended size for the cable type, pass the heating cable through the gland nut and its seal</p>	<p>2 : Strip the outer jacket of the heating cable to the required length.</p>
<p>3</p>	<p>4</p>
<p>3 : Cut the braid to the requested size.</p>	<p>4 : Strip the insulating jacket around the heating part to the required length.</p>

* These exclusive tools are available in accessories section

3 ways "Tee" connection box for heat tracing cables, without thermostat, for traditional or self-regulating cables

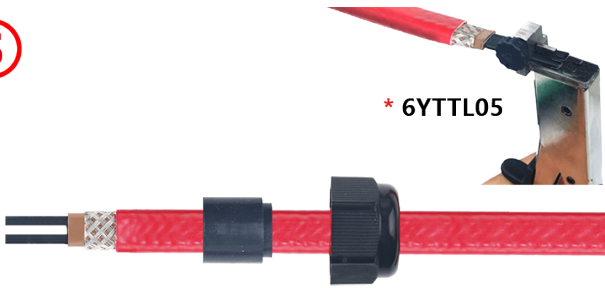
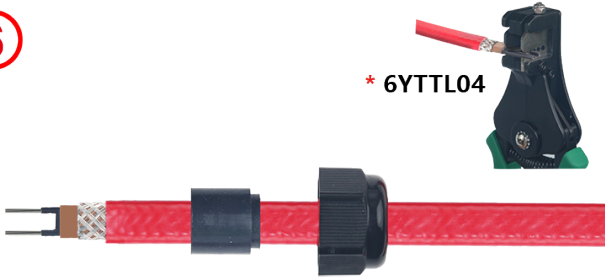
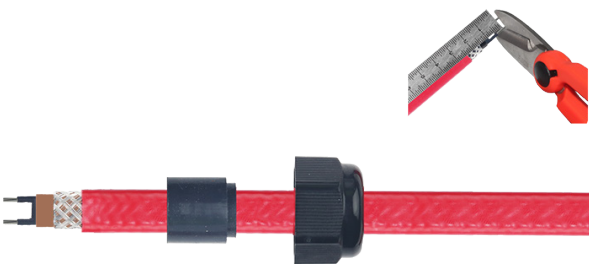
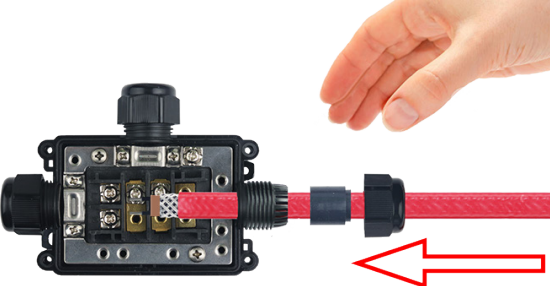
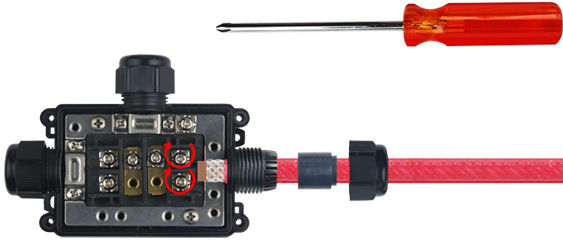
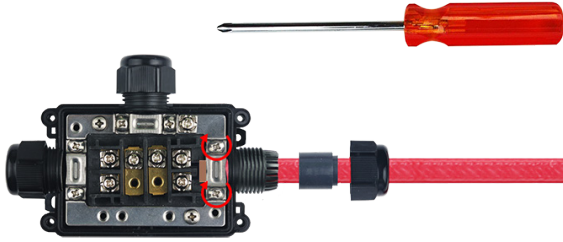
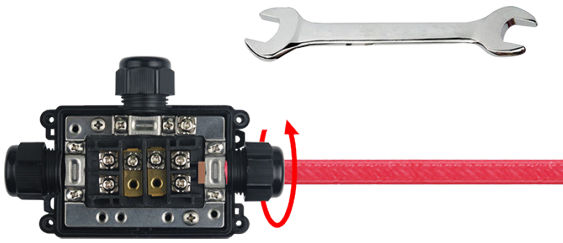

Because of permanent improvement of our products, drawings, descriptions, features used on these data sheets are for guidance only and can be modified without prior advice

<p>5</p>  <p>* 6YTTL05</p>	<p>6</p>  <p>* 6YTTL04</p>
<p>5 : Cut the heating part between the two bus wires to the required length</p>	<p>6 : Strip the two bus wires over the required length</p>
<p>7</p> 	<p>8</p> 
<p>7 : If necessary, cut the stripped bus wires to length</p>	<p>8 : Unscrew and remove the saddle, unscrew and remove the terminal screws if necessary, then pass the cable through the cable gland.</p>
<p>9</p> 	<p>10</p> 
<p>9 : Put the bus wire and the braid at the place they will be tightened. Tighten the terminal block screws on the bus wires. Recommended torque 1.2 Nm.</p>	<p>10 : Replace the saddle and tighten it on the metal braid. Recommended torque 1.2 Nm.</p>
<p>11</p> 	
<p>11 : Slide the flat cable gasket into the cable gland and tighten the nut. Maximum torque 3Nm. Connect any other cables and close the lid.</p>	

* These exclusive tools are available in accessories section

3 ways "Tee" connection box for heat tracing cables, without thermostat, for traditional or self-regulating cables



Round cable assembly steps

①

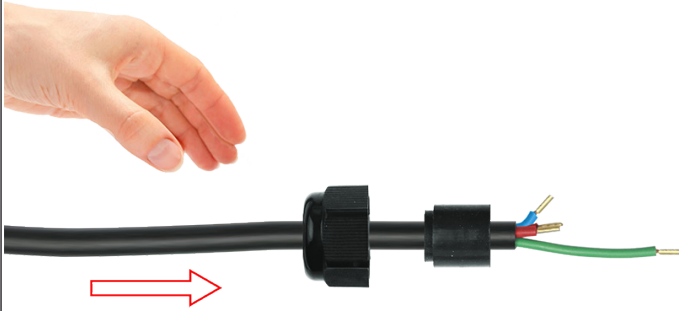

1 : Remove outer insulation on round cable as requested by drawing. Eventually, crimp cable shoes. Slide the cable gland nut on the cable. Select the compatible diameter gasket and slide it on the cable.

②



2 : Put the neutral, line and ground wires inside the screw terminals and tighten them. Recommended torque 1.2 Nm.

③



3 : Tighten the saddle screw. Recommended torque 1.6 Nm.

④

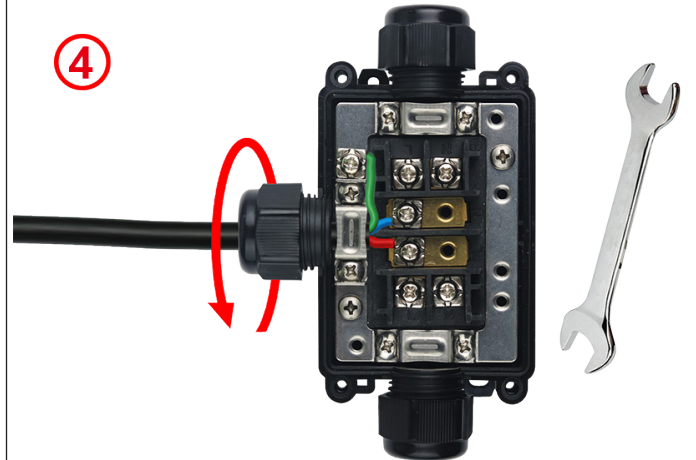

4 : Slide the round cable seal into the cable gland and tighten the nut. Maximum torque 3N.m.

4 cross ways connection box for heat tracing cables, without thermostat, for traditional or self-regulating cables



4 cross ways	Screw and square washer terminals	Wire gauge	Cables diameters		Type
		1~2.5mm ²	 6 ~ 12.2 8.7 x 3.5 ~ 14.2 x 9.2		Y28

Wall mounting

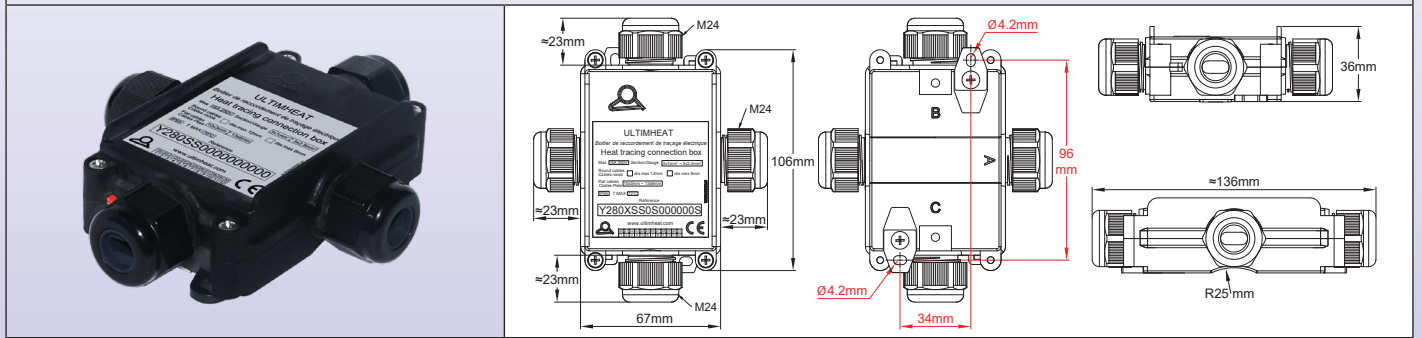

Pipe surface mounting

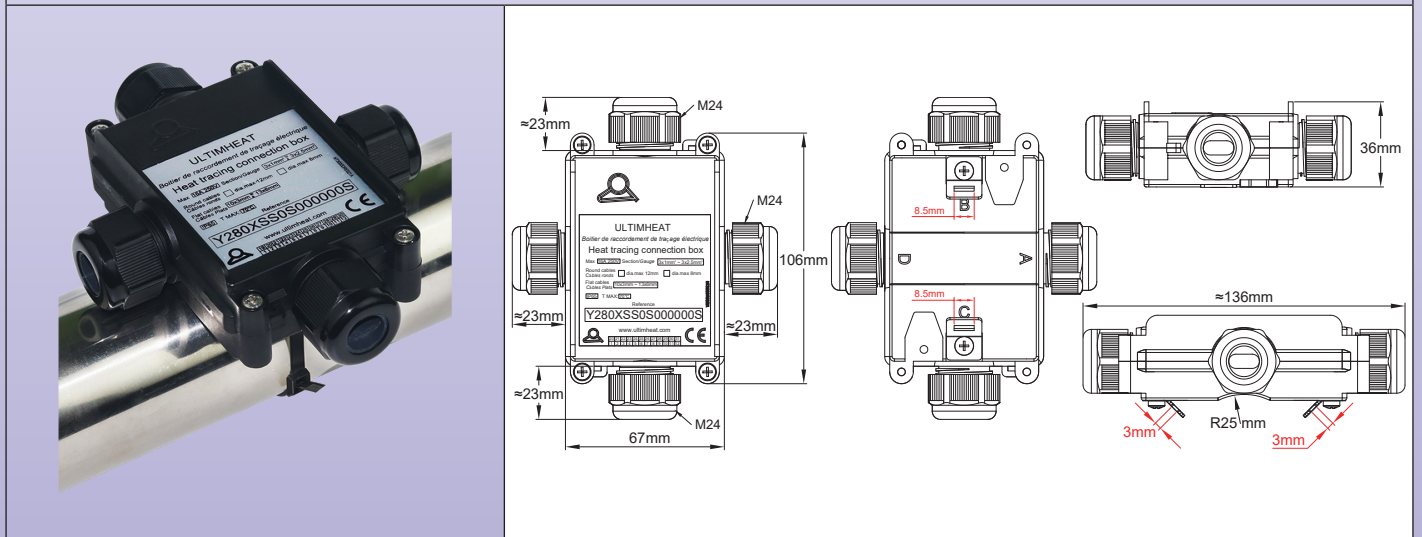

50mm offset mounting for pipes with thermal insulation (optional accessory)

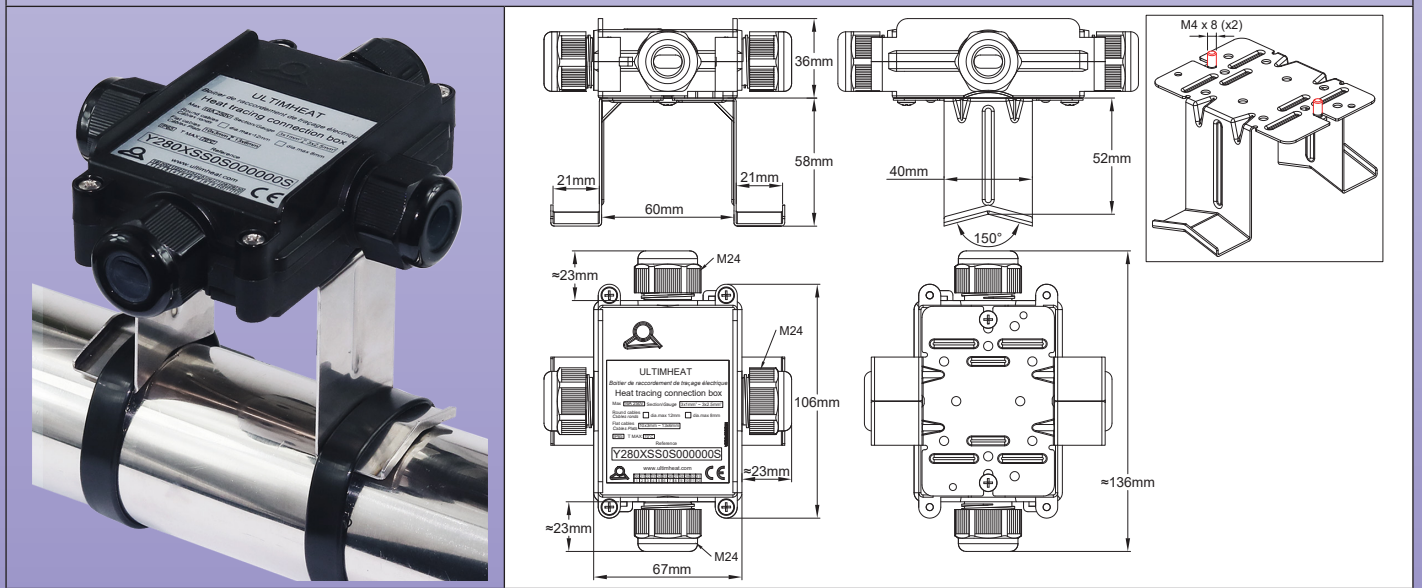

Because of permanent improvement of our products, drawings, descriptions, features used on these data sheets are for guidance only and can be modified without prior advice

4 cross ways connection box for heat tracing cables, without thermostat, for traditional or self-regulating cables



Applications

This box is used to connect **one power cable to 3 heating cables**, or to ensure the continuity of a power cable between several boxes, and connecting a single heating cable on each box.

It can be mounted on a flat surface, or on a pipe.

The terminal blocks are easily accessible and the **connection is simple, including for self-regulating flat cables with metallic protective braid.**

Main features

Material: Polyamide 6 black, 96mm × 67mm × 36mm (Cable glands not included). Excellent UV resistance.

Waterproof grade: IP65.

Mounting: 2 removable wall mounting bracket, holes distance 96mm. Pipe mounting with cable tie also possible with 2 small metal tabs screwed on backside.

Terminals:

- Screw terminals with captive toothed square washers accepting stranded or rigid conductors.
- The mechanical tightening of the cable is ensured by a screwed metal saddle, usable on round or flat cable.

This patented saddle also ensures the earthing of the metal braid of the heating cables.

- Wire gauge: 3 × 1mm² to 3 × 2.5mm².

- Maximum permissible intensity: 16A 250V.

Cables outlet: with M24 cable glands, with 70 shore NBR gaskets (Silicone is available on request).

- **Maximum diameter of round cables:** 8; 12mm depending on the gaskets installed.

- **Limit sizes of oblong cables:**

- from 8 × 5 to 9.5 × 6mm

- from 9.5 × 2.5 to 11 × 3.5mm

- from 11 × 4 to 13 × 6mm

- from 12.5 × 8 to 14.2 × 9.2mm

For more information about tightening possibilities on round and oblong cables, see the catalogue page on 6YTP cable glands.

Inviolability: The case can receive one or two seals (delivered with 5 red seals).

Sealing: supplied with 5 red plastic ties for use in the sealing holes.

Easy assembly: Assembly is made with full access to terminals when cover is removed. Mounting on wall or pipe can be made with cover removed or cover assembled.

Accessory: Bracket in stainless steel for offset mounting on pipe with up to 50mm insulation thickness. Can be screwed on the two M4 threads on backside. See types 6YTP in the accessories section.

Options:

- Version for 4 heating cables without power supply cable.

- Version for 2 heating cables and 2 power supply cables.

- Version with three cable glands, for 2 heating cables and 1 power supply cable (corresponds to the Y70 model rotated 90° relative to the piping).

Consult us for parts numbers of simplified models with only one dimension of cable gland gasket for round wire and flat wires, customized label, and specific set of accessories for pipe mounting (OEM versions).

Main part numbers

(These models include 2 small metal tabs for pipe surface mounting*).

Part numbers	Seals on side A**	Seals on side B**	Seals on side C**	Seals on side D**
Y280PFFF000000SO	Silicone seal for round cable dia. 12.2mm max.	Silicone seal for oblong cable max. size 13x6mm.	Silicone seal for oblong cable max. size 13x6mm.	Silicone seal for oblong cable max. size 13x6mm
Y280KNNN000000SO	NBR seal for round cable dia. 12.2mm max.	NBR seal for oblong cable max. size 13x6mm.	NBR seal for oblong cable max. size 13x6mm.	NBR seal for oblong cable max. size 13x6mm
Y280PSSS000000SO	Silicone seal for round cable dia. 12.2mm max.	Set of Silicone seal for oblong cables max. size 9.5x6; 11x3.5; 13x6 and 14.2x9.2mm.	Set of Silicone seal for oblong cables max. size 9.5x6; 11x3.5; 13x6 and 14.2x9.2mm.	Set of Silicone seal for oblong cables max. size 9.5x6; 11x3.5; 13x6 and 14.2x9.2mm.
Y280KXXX000000SO	NBR seal for round cable dia. 12.2mm max.	Set of NBR seals for oblong cables max. size 9.5x6; 11x3.5; 13x6 and 14.2x9.2mm.	Set of NBR seals for oblong cables max. size 9.5x6; 11x3.5; 13x6 and 14.2x9.2mm.	Set of NBR seals for oblong cables max. size 9.5x6; 11x3.5; 13x6 and 14.2x9.2mm.

* Models without the 2 small tabs, replace 0SO by 000 in the part number.

** Silicone seals recommended for ambient temperature higher than 80°C.

Reference:

- **Y280SS** (Includes a set of gaskets for round cables, 3 sets of gaskets for oblong cables and 2 small metal tabs for pipe surface mounting).

**4 cross ways connection box for heat tracing cables,
without thermostat, for traditional or self-regulating cables**



Stripping dimensions of round and oblong cables

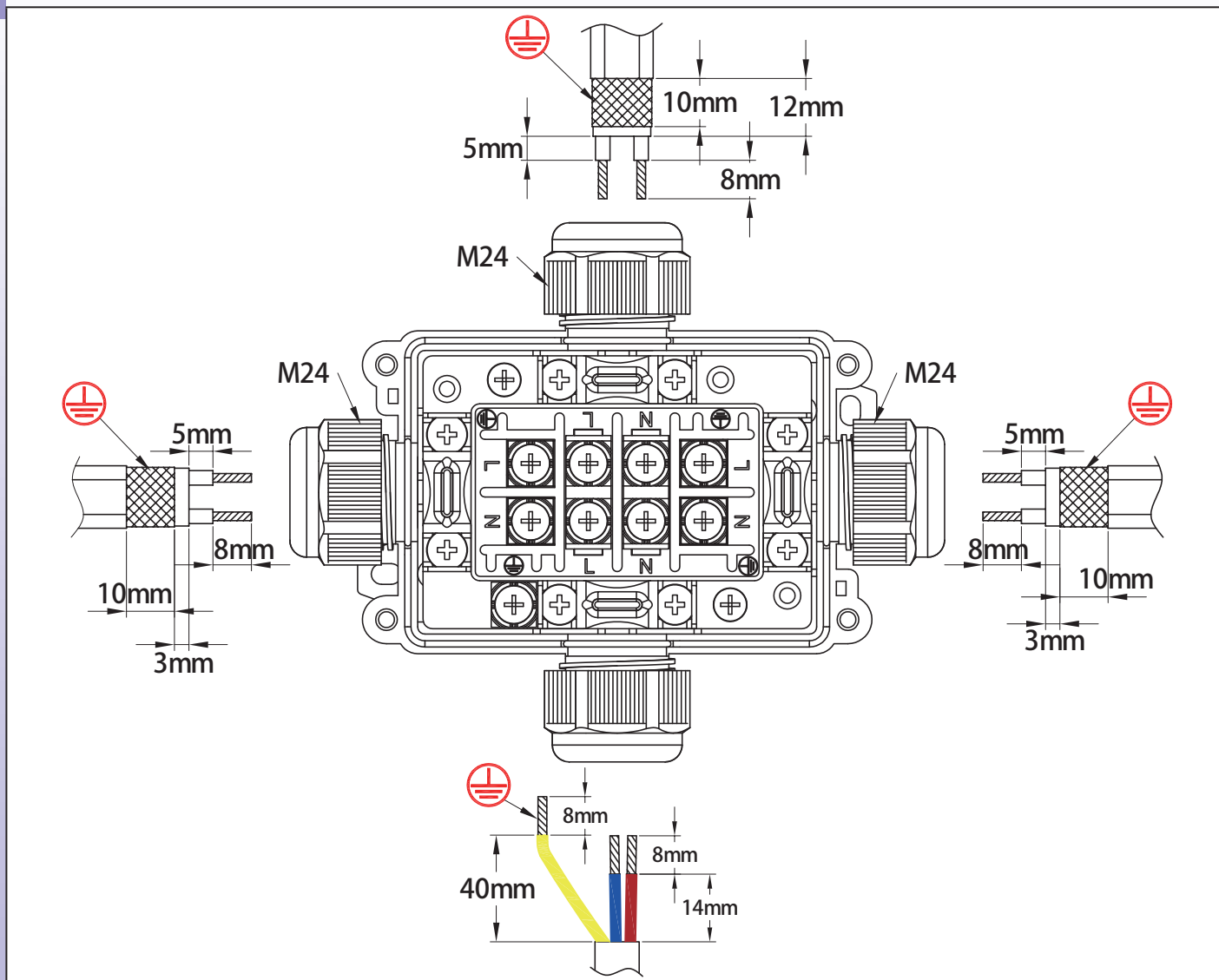

Because of permanent improvement of our products, drawings, descriptions, features used on these data sheets are for guidance only and can be modified without prior advice

4 cross ways connection box for heat tracing cables, without thermostat, for traditional or self-regulating cables



Self-regulating cables assembly steps

(More details on the different methods of preparing termination for various types of cables are available in the technical introduction).

<p>1</p>	<p>2</p>
<p>1 : After selecting the cable gland seal to the recommended size for the cable type, pass the heating cable through the gland nut and its seal.</p>	<p>2 : Strip the outer jacket of the heating cable to the required length.</p>
<p>3</p>	<p>4</p>
<p>3 : Cut the braid to the requested size.</p>	<p>4 : Strip the insulating jacket around the heating part to the required length.</p>
<p>5</p>	<p>6</p>
<p>5 : Cut the heating part between the two bus wires to the required length.</p>	<p>6 : Strip the two bus wires over the required length.</p>
<p>7</p>	<p>8</p>
<p>7 : If necessary, cut the stripped bus wires to length.</p>	<p>8 : Unscrew and remove the saddle, unscrew and remove the terminal screws if necessary, then pass the cable through the cable gland.</p>
<p>9</p>	<p>10</p>
<p>9 : Put the bus wire and the braid at the place they will be tightened. Tighten the terminal block screws on the bus wires. Recommended torque 1.2 Nm</p>	<p>10 : Replace the saddle and tighten it on the metal braid. Recommended torque 1.2 Nm.</p>
<p>11</p>	
<p>11 : Slide the flat cable gasket into the cable gland and tighten the nut. Maximum torque 3Nm. Connect any other cables and close the lid.</p>	





* These exclusive tools are available in accessories section

Because of permanent improvement of our products, drawings, descriptions, features used on these data sheets are for guidance only and can be modified without prior advice

4 cross ways connection box for heat tracing cables, without thermostat, for traditional or self-regulating cables

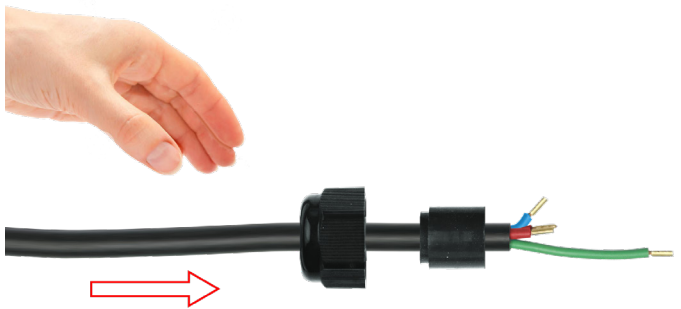

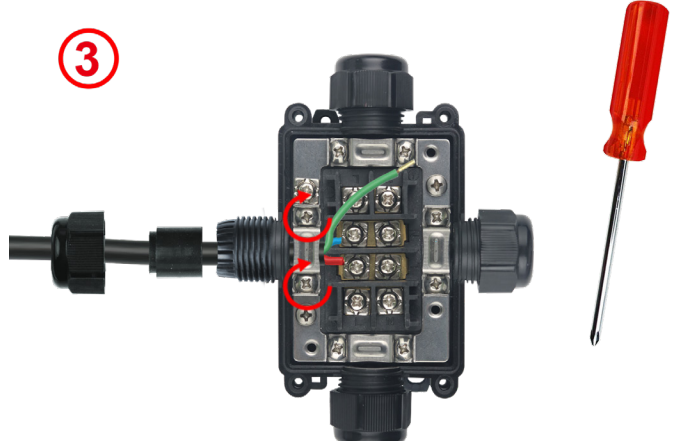
Round cable assembly steps

<p>①</p> 	<p>②</p> 
<p>1 : Remove outer insulation on round cable as requested by drawing. Eventually, crimp cable shoes. Slide the cable gland nut on the cable. Select the compatible diameter gasket and slide it on the cable.</p>	<p>2 : Put line, neutral and ground wires inside the screw terminals and tighten them. Recommended torque 1.2Nm.</p>
<p>③</p> 	<p>④</p> 
<p>3 : Tighten the saddle screw. Recommended torque 1.6 Nm.</p>	<p>4 : Slide the round cable seal into the cable gland and tighten the nut. Maximum torque 3N.m.</p>

Because of permanent improvement of our products, drawings, descriptions, features used on these data sheets are for guidance only and can be modified without prior advice

Connection box, with pipe mounting leg, for heat tracing cables, for **two traditional or self-regulating cables, one power supply cable and temperature sensor cable**



Because of permanent improvement of our products, drawings, descriptions, features used on these data sheets are for guidance only and can be modified without prior advice

4 parallel ways	Screw and square washer terminals	Wire gauge	Cables diameters		Type
		$9 \times 1 \sim 2.5\text{mm}^2$ + $3 \times 0.5 \sim 1.5\text{mm}^2$			Y29C & Y29D

With M24 and M12 cable glands (Y29C) and built in connection block

With M24 and M12 cable glands (Y29C) and Din rail for customer's connection blocks

With 5 ways connector (Y29D)

Connection box, with pipe mounting leg, for heat tracing cables,
for **two traditional or self-regulating cables, one power supply cable and temperature sensor cable**



Because of permanent improvement of our products, drawings, descriptions, features used on these data sheets are for guidance only and can be modified without prior advice

<p>Example of connection with connector on an electronic temperature control box</p>	<p>Example of connection by cable gland on an electronic temperature control box</p>
<p>Example of connection with a wall mounting ambient temperature electronic thermostat type 6F62NC.</p>	<p>Example of mounting on the rear side of a mechanical bulb and capillary thermostat for measurement of pipe temperature</p>
<p>Example of mounting an antifreeze disc thermostat type 49JB on a 20mm diameter hole made on a lateral side.</p>	<p>Example of mounting temperature sensor type TSJ on a 20mm diameter hole made on a lateral side.</p>

Applications

This box allows to connect **a power supply cable to 2 heating cables**. It also allows the conductors of the temperature sensor cable to be connected. **The mounting on a cylindrical foot allows a simple crossing of the thermal insulation of the piping and its protective sheath by a simple hole diameter 50mm.** The foot can thus be placed at the same time as the temperature sensor and the heating cables, and remains on standby during the installation of the insulation and the protective sheath. The connection box then can be mounted when these operations are completed, and the cables can be connected at this time. The terminal blocks are easily accessible and the **connection is simple, including for self-regulating flat cables with metallic protective braid.**

Connection box, with pipe mounting leg, for heat tracing cables, for two traditional or self-regulating cables, one power supply cable and temperature sensor cable



Main features

Material: Polyamide 6 black, 160mm × 100mm × 60mm (Cable glands not included). Excellent UV resistance.

Waterproof grade: IP66, IP69K (Withstand hot pressure hot water washing).

Impact resistance: IK10 (highest), except cable glands and connector.

Mounting: It is made by a central foot in PPS resistant to temperature, being mounted on the pipe by two nylon cable ties or two metal hose clamps. The distance between the housing and the piping is 110 to 120mm (Varies depending on the diameter of the piping)

Terminal block: All terminals are fitted with screws with a vibration resistant square washer, allowing clamping on all types of conductors, flexible or rigid. **The connection jumpers between the terminals are prewired and invisible.**

- Allowable sections: 1mm² to 2.5mm² on the connection terminals of the power cables and the heating cables; 0.5mm² to 1.5mm² on the terminals for the temperature sensor.

- Maximum admissible current: 16A 250V

Power supply input:

3 possible solutions

- 1 / By M24 cable glands, with NBR 70 Shore gasket (Silicone is possible on request).

Maximum cable diameter: 6; 8 or 12.2mm depending on the gasket installed. (Comes with a set of 3 gaskets covering the different ranges of diameters).

- 2 / By 5-way waterproof connector (3 ways for power supply conductors and 2 ways for the temperature sensor)

- 3 / By M25 cable gland (available on request).

Input of the temperature sensor cable, coming from the temperature control system:

2 possible solutions

- By the 5-way connector (see above).

- By M12 cable gland.

Heating cables outlet: By the central foot, with silicone seals

- Limit sizes of flat cables:

- from 8 × 5 to 9.5 × 6mm

- from 9.5 × 2.5 to 11 × 3.5mm

- from 11 × 4 to 13 × 6mm

(Comes with a set of 3 fittings covering the different dimensions).

For more information on the different seals used, see the catalogue page about the 6YTPP pipe mounting feet.

Temperature sensor conductor output:

- **Two possible solutions**

- 1 / By the central foot, which has a passage for cables from 2.8 to 3mm, usual size for NTC, PT100 and thermocouples.

- 2 / By an M12 cable gland

Inviolability: The box can receive one or two seals (Comes with 5 red seals)

Easy assembly: Assembly is done with the lid open, with wide access.

Compatibility: On its rear side, this box has M4 threaded inserts to mount mechanical thermostats of the Y0D8, Y0D9, Y0A8, Y0A9, Y0D9 series (see other pages of this catalogue), allowing a measurement of the ambient temperature or of the pipe surface temperature.

Standard variation: Replacement of the connection block by a Din rail for customer's connection blocks.

Options:

- Additional M20x1.5 thread for antifreeze disc thermostat or ambient temperature sensor incorporation.

- Empty box without terminal block and without Din Rail

- Box without drilling or cable gland or foot threads.

Consult us for parts numbers of simplified models with only one dimension of cable gland gasket for round wire and flat wires and customized label, (OEM versions).



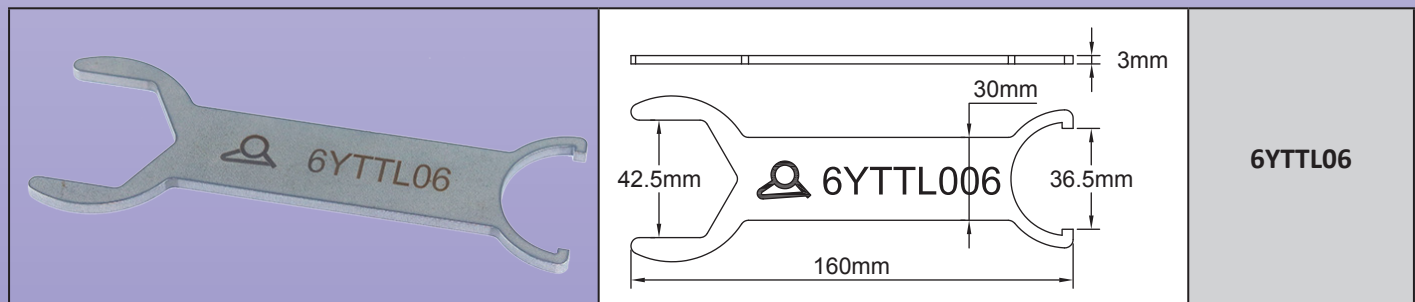

Wrench for leg assembly (To be ordered separately)



**Connection box, with pipe mounting leg, for heat tracing cables,
for two traditional or self-regulating cables, one power supply cable and temperature sensor
cable**

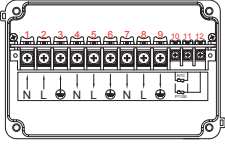
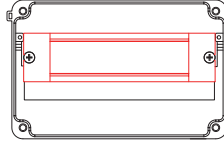

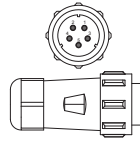
Main references (1" foot included)

References		M24 cable gland	M12 cable gland	5 ways connector	Leg seal with temperature sensor crossing*	Leg seal without temperature sensor crossing*
Built in connection block	Rail Din					
						
Y29BGYS300P6930	Y29BGYS300P6DN0	1	0	0	1	0
Y29CGYS316P6930	Y29CGYS316P6DN0	1	1	0	1	0
Y29EGYS326P6930	Y29EGYS326P6DN0	1	2	0	1	0
Y29DC6S300P6930	Y29DC6S300P6DN0	0	0	1	1	0
Y29FC6S316P6930	Y29FC6S316P6DN0	0	1	1	1	0
Y29BGYT300P6930	Y29BGYT300P6DN0	1	0	0	0	1
Y29CGYT316P6930	Y29CGYT316P6DN0	1	1	0	0	1
Y29EGYT326P6930	Y29EGYT326P6DN0	1	2	0	0	1
Y29DC6T300P6930	Y29DC6T300P6DN0	0	0	1	0	1
Y29FC6T316P6930	Y29FC6T316P6DN0	0	1	1	0	1

* Supplied with a set of 3 seals covering the main dimensions of oblong heating cables and a cable passage plug if you use a single heating cable

Because of permanent improvement of our products, drawings, descriptions, features used on these data sheets are for guidance only and can be modified without prior advice

Update 2026/06/15

Connection box, with pipe mounting leg, for heat tracing cables,
for **two traditional or self-regulating cables, one power supply cable and temperature sensor cable**



Stripping dimensions of heating cables*.

(More detailed instructions are available in the technical introduction).

* : These dimensions may change on models with DIN rail and customer's connection block.

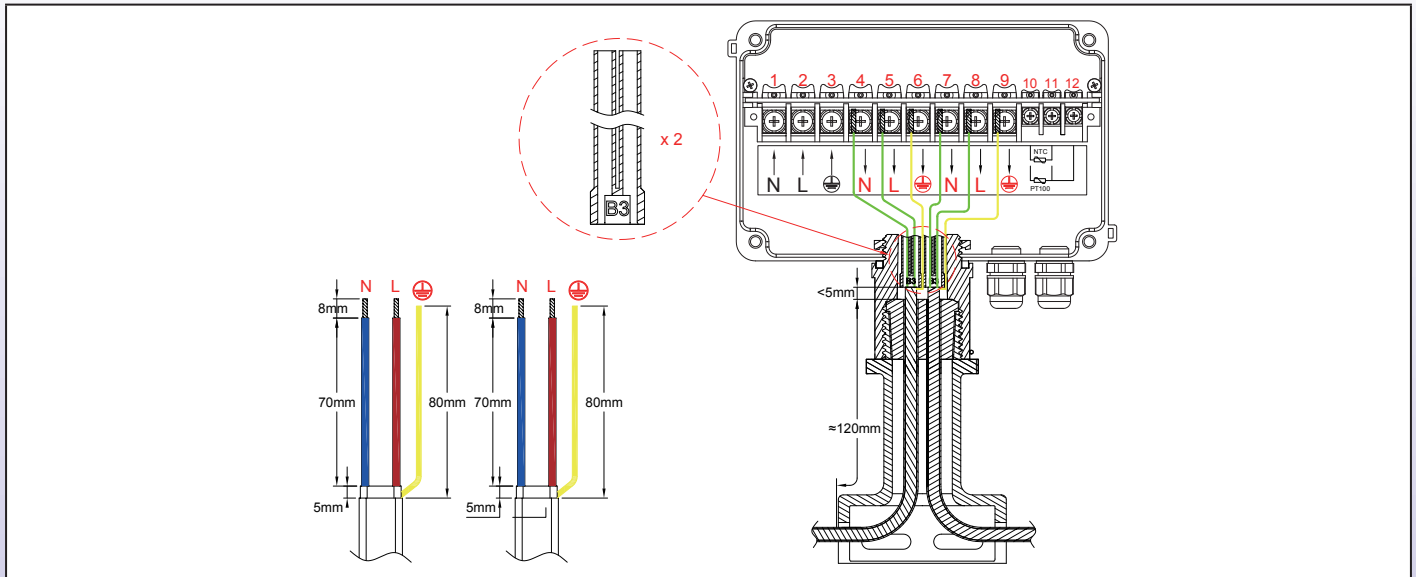

Self-regulating cables assembly steps

<p>1</p> <p>* 6YTTL04</p>	<p>2</p>
<p>1 : Cut the cable, remove the external jacket on the requested length.</p>	<p>2 : Unweave the braid on all this length with a tool with round edges or a screw driver. (For more details about this step #2, read the technical introduction).</p>
<p>3</p>	<p>4</p> <p>* 6YTTL04</p>
<p>3 : Twist the braid to make a round wire.</p>	<p>4 : Remove the electric insulation sleeving on the requested length.</p>
<p>5</p> <p>* 6YTTL05</p>	<p>6</p> <p>* 6YTTL04</p>
<p>5 : Cut and remove the heating section between the two bus wires on the requested length.</p>	<p>6 : Strip off the semiconductor plastic remaining on the bus wire ends to the requested length.</p>

* These exclusive tools are available in accessories section

Because of permanent improvement of our products, drawings, descriptions, features used on these data sheets are for guidance only and can be modified without prior advice

Connection box, with pipe mounting leg, for heat tracing cables, for two traditional or self-regulating cables, one power supply cable and temperature sensor cable



Because of permanent improvement of our products, drawings, descriptions, features used on these data sheets are for guidance only and can be modified without prior advice

<p>7 : Cut the stripped bus wires and the ground wire to the requested length.</p>	<p>8 : Place the foot on the heating cables and on the temperature sensor cable, bringing them out from above, then slide the gasket over the cables. The outer insulating sheath must protrude from the gasket.</p>
<p>9 : Pour RTV silicone inside the main hole of the silicone boot.</p>	<p>10 : Fill the mouth of the silicone boot with silicone resin (RTV). Slide the boot over the conductors of the heating cables, leaving the earth conductor outside. These boots can also be replaced by a heat-shrinkable tube.</p>
<p>11 : Compress the seal by screwing the upper part of the foot. When tightening is complete, a small spring comes to block the assembly (To disassemble, it is necessary to remove this small semi-circular spring).</p>	<p>12 : Place the gasket in the upper recess of the foot, then the box above. Orient the housing according to the desired position, then place and tighten the toothed nut until it locks.</p>
<p>13 : Connect the conductors and the temperature sensor according to the wiring diagram. Connect the power supply cable. Close the control box.</p>	

Connection box, with pipe mounting leg, for heat tracing cables,
for **two traditional or self-regulating cables, one power supply cable and temperature sensor cable**



Stripping dimensions of power supply cable.

(These dimensions may change on models with DIN rail and customer's connection block)

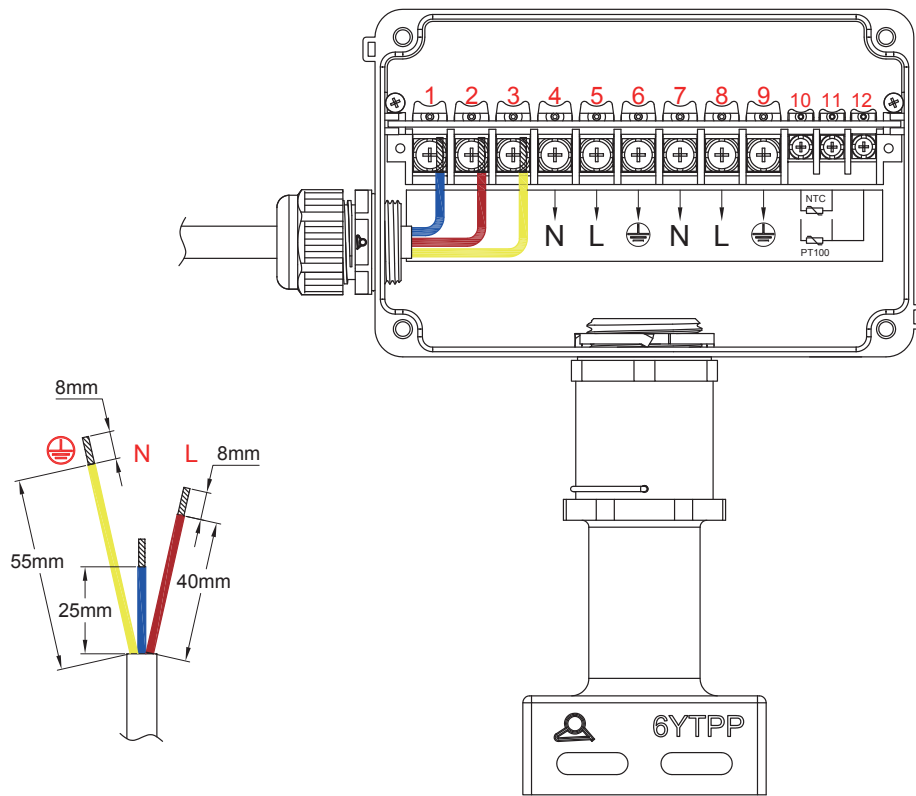

Round cable assembly operations (Types with M24 cable gland)

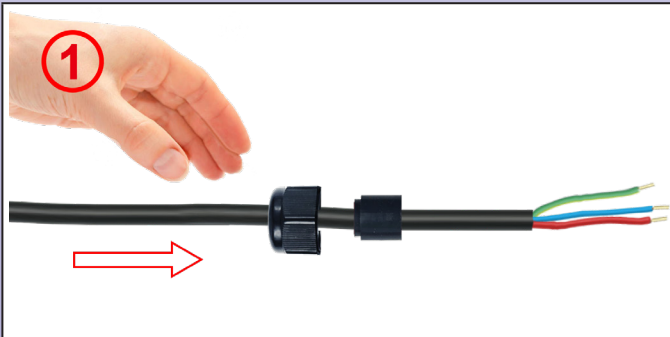

1 : Remove outer insulation on round cable as requested by drawing. Eventually, crimp cable shoes. Slide the cable gland nut on the cable. Select the compatible diameter gasket and slide it on the cable.



2 : Put the neutral and line wires inside the screw terminals and tighten them. Recommended torque 1.6 Nm.



3 : Slide the ground wire inside the ground terminal and tighten the screw. Recommended torque 1.6 Nm



4 : Slide the round cable gasket into the cable gland and tighten the nut. Maximum torque 6N.m.

Because of permanent improvement of our products, drawings, descriptions, features used on these data sheets are for guidance only and can be modified without prior advice

Connection box, with pipe mounting leg, for heat tracing cables,
for **two traditional or self-regulating cables, one power supply cable and temperature sensor cable**



The 2 ways of temperature sensor cable wiring to the pipe

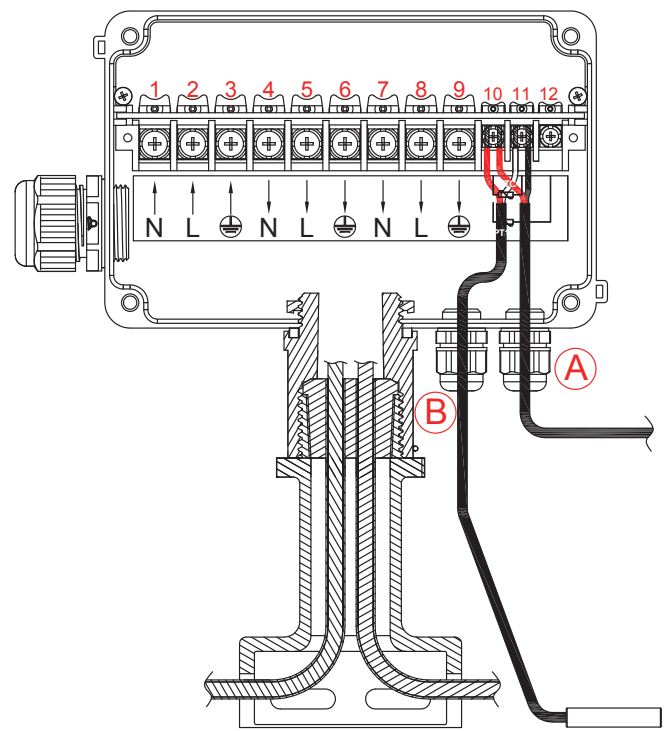
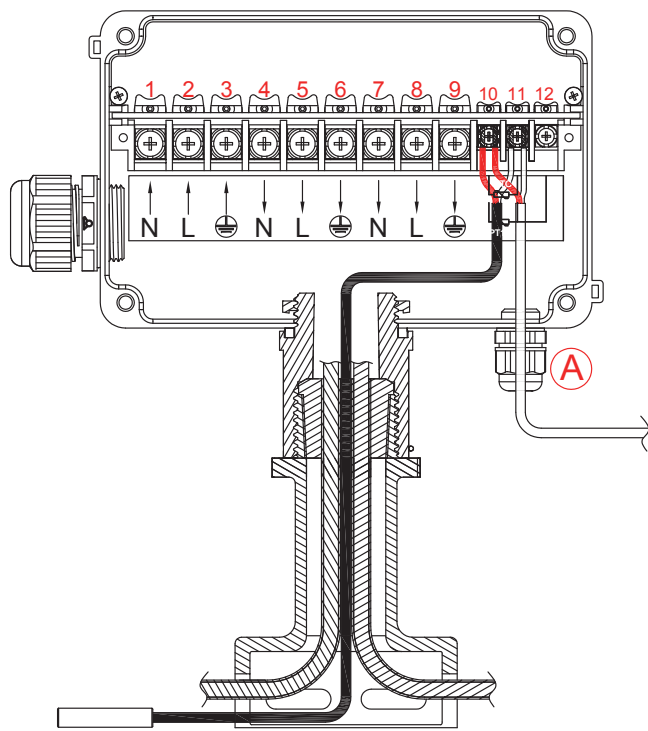

By the foot gasket :

The temperature sensor cable from the control system arrives through the M12 cable gland (A), and is connected to the terminal block. It then goes back to the piping through the foot gasket. A variant consists in having it arrive by the M24 cable gland or by the 5-way connector. The temperature sensor cable can be 2-conductor (NTC, Pt100 2-wire or thermocouple) and is then connected to terminals 10 and 11, or 3-wire (Pt100 3-wire) and is then connected to terminals 10, 11 and 12.

By independent M12 cable gland :

The temperature sensor cable from the control system arrives through the M12 cable gland (A), and is connected to the terminal block. It then goes back to the piping through a second M12 cable gland (B). A variant consists in making it arrive by the M24 cable gland or by the 5-way connector. The temperature sensor cable can be 2-conductor (NTC, Pt100 2-wire or thermocouple) and is then connected to terminals 10 and 11, or 3-wire (Pt100 3-wire) and is then connected to terminals 10, 11 and 12.

Because of permanent improvement of our products, drawings, descriptions, features used on these data sheets are for guidance only and can be modified without prior advice



Section 5

Connection boxes for heat tracing cables, with insulation piercing terminals, for self-regulating cables. Connections in industrial environments but **not in hazardous environments. For hazardous environments see catalogue 4**



Because of permanent improvement of our products, drawings, descriptions, features used on these data sheets are for guidance only and can be modified without prior advice

The unrivaled advantages of Ultimheat insulation piercing self-regulating heating cable connection boxes

(Compatible with self-regulating cables with polypropylene,
silicone semiconductor, or fluorinated cores)

Heat tracing accessories

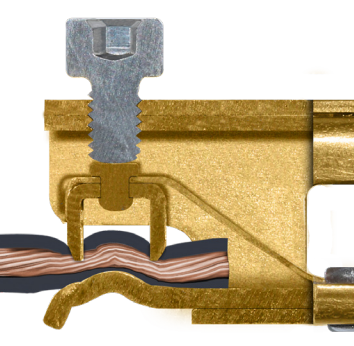
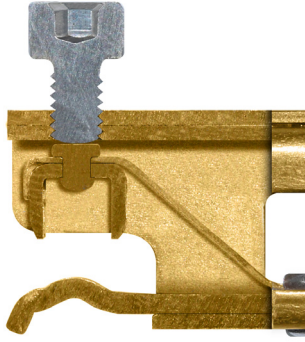
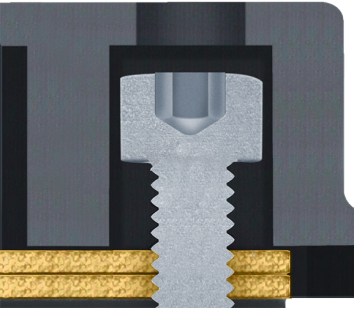

Insulation piercing terminals 4 technical improvements

			
<p>1: Anti-vibration blocking and resistant to thermal cycles of the screws after tightening.</p>	<p>2: Double chisels reducing contact resistance with electrical conductors and eliminating hot spots.</p>	<p>3: Terminal opening spring facilitating insertion and allowing possible replacement of heating cables.</p>	<p>4: Captive screws: they don't fall down during connection</p>

Connection on "cold" conductors 5 technical improvements

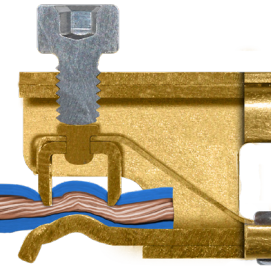
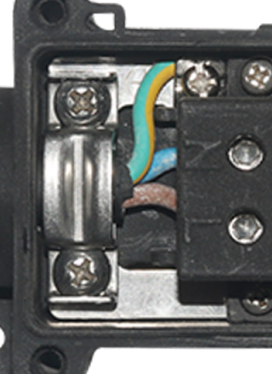
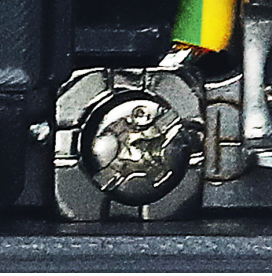
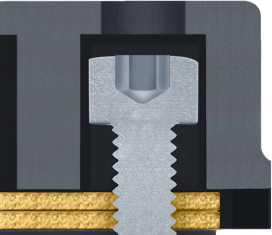
				
<p>1: Anti-vibration blocking of the terminal block screws, resistant to thermal cycles.</p>	<p>2: Terminals allow flexible stranded or rigid conductors from 0.75 to 4mm², stripped or not, and automatically compensate for variations in insulation thickness if the latter creeps</p>	<p>3: Large insertion hole with guide ramps. <u>No tortuous circuit to make to these conductors.</u></p>	<p>4: Clearly identified earth terminal with anti-loosening notched washer</p>	<p>5: Captive screws: they don't fall down during connection</p>

Because of permanent improvement of our products, drawings, descriptions, features used on these data sheets are for guidance only and can be modified without prior advice

Installation

3 technical improvements



1: Two built-in tabs for mounting on a flat wall.



2: Two removable PA66 plastic tabs, for fitting on pipes, providing a **10mm** offset from the tube. Ideal and economical for applications with low insulation thickness and pipe temperature below 100°C. Clamping on metal or PVC piping can be made by nylon tie or metal clamp (These tabs are included as standard).



3: One stainless steel bracket, for offset mounting on piping, allowing the enclosure to be locked in after the insulation and its protection have been installed. Allow an insulation thickness of **50mm**, and can be used on hot pipes. Clamping on metal or PVC piping by nylon tie or metal clamp. (Legs available as an accessory.)

Lids

4 technical improvements



1: Four captive stainless-steel screws tightening on metal inserts. No screwing into the plastic, no fragile hinges.



2: Riveted identification label, anodized aluminum, laser printed, weatherproof and tamperproof.

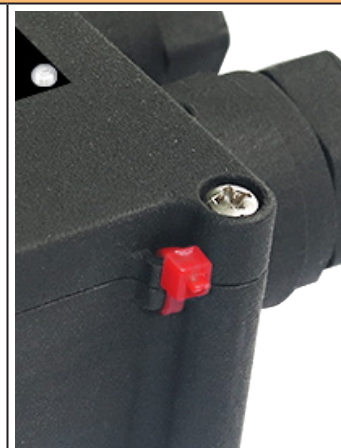

3: Two rings for safety seals located diagonally. These rings can also be used to attach mandatory labels.



4: Graduated scale in cm, engraved, with mechanical stop at 0 cm, to ease the stripping length measurement.

Cable glands 5 technical improvements

<p>1: Specially designed to comply with the high tear force requested by industrial and hazardous area standards, the built-in cable glands are made of black PA66, UV resistant. They are IP67 and IP69K, therefore they withstand immersion and high-pressure hot water washing.</p>	<p>2: Thanks to two springs, the locking saddle for round or flat cable maintains the earth continuity of the metal braid in the event of deformation of the cable. (Patented).</p>	<p>3: This locking saddle provides a powerful tightening of the cable which is independent of the tightening torque of the gland nut, avoiding any tearing.</p>	<p>4: Captive saddle screws.</p>	<p>5: A whole range of gaskets in 70 shore silicone and in 70 shore NBR makes it possible to cover all the dimensions of round or flat cables.</p>

Because of permanent improvement of our products, drawings, descriptions, features used on these data sheets are for guidance only and can be modified without prior advice



2 ways in line connection box in PPS for heat tracing cables, with insulation piercing terminals, for self-regulating cables

2 ways in line	Insulation piercing	Wire gauge	Cables diameters		Types
		1~6mm ² 32A	 8 ~ 16 8 x 5 15 x 7		Y40

1. Red seal; 2. Stainless steel chain

Wall or surface mounting by the 2 holes on the enclosure

1. Red seal; 2. Stainless steel chain

Direct pipe surface mounting with **short PPS legs** (mounting option 1)

1. Red seal; 2. Stainless steel chain

Pipe surface mounting with short **stainless steel legs bracket**, for 10mm thermal insulation (Mounting option 2)

Because of permanent improvement of our products, drawings, descriptions, features used on these data sheets are for guidance only and can be modified without prior advice

Explosion proof connection boxes



Because of permanent improvement of our products, drawings, descriptions, features used on these data sheets are for guidance only and can be modified without prior advice

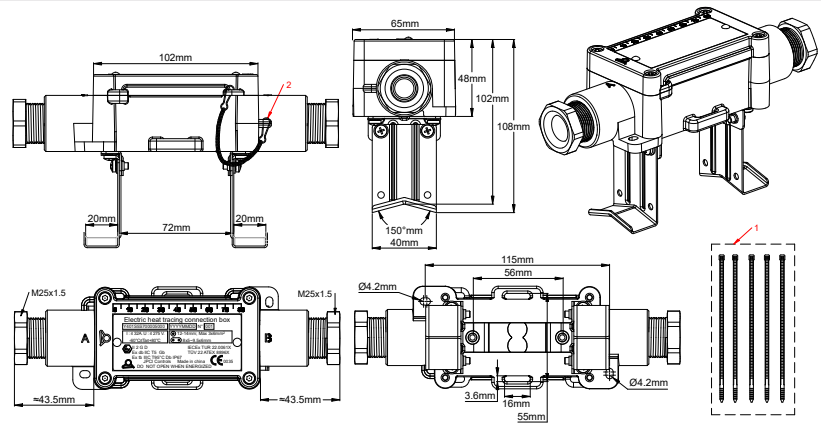

1. Red seal; 2. Stainless steel chain

Example of mounting at distance of the pipe with the **long legs** stainless steel bracket (Mounting option 5)

Applications

This box is used to connect a **power supply cable to a self-regulating cable, or two self-regulating cables end to end.** It can be mounted flat on a surface, or on a pipe, including with insulation up to 50mm thick.

Access to connectors is very easy, and the connection is very simple, in particular for flat self-regulating cables with **metallic protective braid.**

They can be used in domestic and industrial environments as well as in explosive atmospheres.

They are particularly suited to industrial or saline environments, indoors or outdoors.

Approvals:

- **Industrial applications in electrical heat tracing** according to IEC 62395.
- **Applications in explosive environments:** These boxes are approved as increased safety "e": (Device preventing the production of sparks at the connections by ensuring the necessary mechanical support and insulation).

Optional accessories:

- Cable glands can be fitted with special bolts for use with electrical cable protection tubes with ATEX approvals.

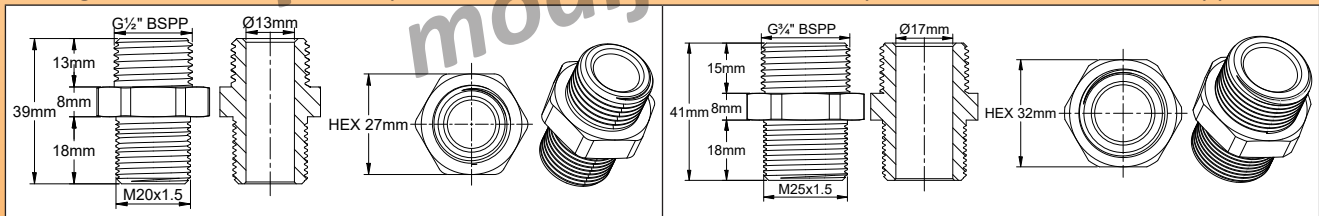

Protection against gas: Ex II 2G Ex cb IIC T5 Gb

Protection against dust: Ex II 2D Ex tb IIIC T95°C Db

Certificates: ATEX: TÜV 22 ATEX 8896 X; IECEx: IECEx TUR 22.0061 X; CCCEX: ??

Main features

Material: Fiber glass reinforced PPS, with very high mechanical strength. Superior UV and very cold temperature resistance.

Waterproof grade: IP67 and IP69K (high pressure hot water washing)

Shocks resistance: The highest, IK10 (Cable gland not included).

Mounting:

- **Wall mounting:** 2 wall mounting lugs allow the mounting on a flat surface. Holes distance 112 × 45mm.
- **Pipe mounting without offset:** Two removable PPS legs are supplied as standard and allow mounting on a tube using a nylon tie or metal clamp. The distance from the tube limits the heating of the box.
- **Pipe mounting with 10mm offset:** Two removable stainless steel legs are supplied as standard and allow mounting on a tube using a nylon tie or metal clamp. The distance from the tube limits the heating of the box.
- **Pipe mounting with 50mm offset:** Two removable stainless steel legs allow the installation of a thermal insulation and its protection before snapping-on the box on it and making electric connections (Available as an accessory, see catalogue page on 6YTQW parts).

Terminals:

- The terminals are piercing the insulation layers with a multiple chisels blade and retain the contact pressure by means of an elastic blade (patented).
- **These terminals are designed to receive self-regulating heating cables with any distance between the bus wires between 2mm and 10mm.**
- These terminals can also possibly be used for conventional conductors of power supply cables.
- All terminals are protected against loosening by vibration or thermal shock.
- The mechanical tightening of the cable is ensured by a screwed metal saddle, usable on round or flat cable.

This patented saddle also ensures the earthing of the metal braid of the heating cables.

- Wire gauge: $3 \times 1 \text{ mm}^2$ to $3 \times 6 \text{ mm}^2$.
- Maximum permissible intensity: 32A 250V.

Cables outlet: with M25 cable glands, with 50 shore silicone gaskets

Inviolability: The case can receive one or two seals (Supplied with 5 red nylon ties for use in the sealing holes).

Ambient temperature limits: -60 to +50° C. (-76°F; +122°F)

Maximum linear power of heating cable: 75W / m.

Maximum intensity: 32A per terminal.

Easy assembly: Assembly is made with full access to terminals when cover is removed. Mounting on wall or pipe can be made with cover removed or cover assembled closed without being hindered by the tightening link

Available round cable gaskets

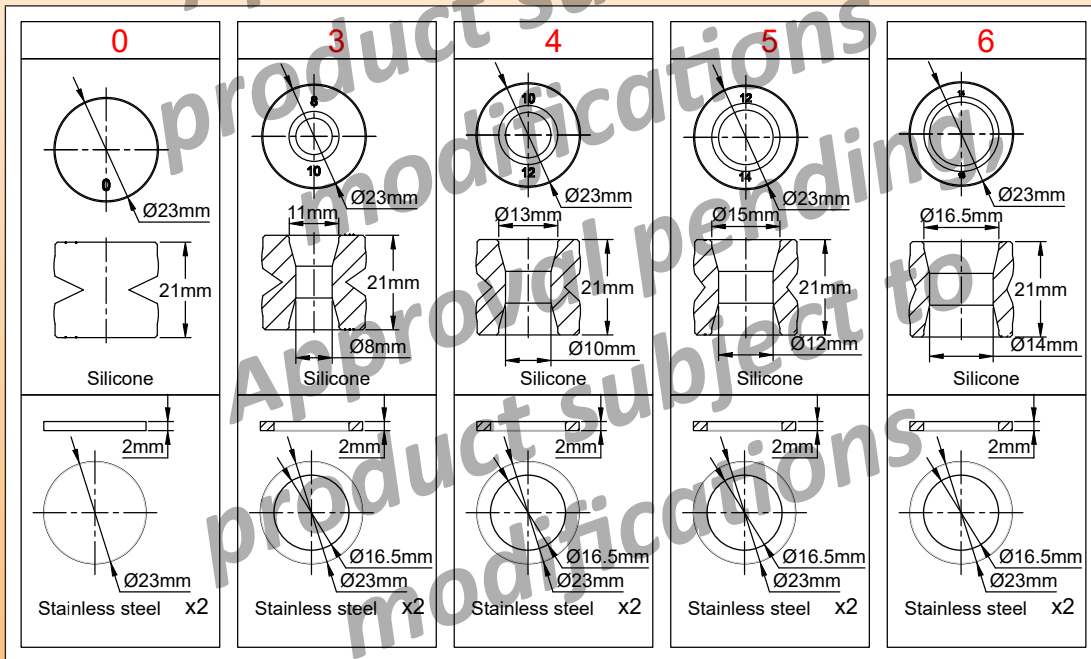

Available flat heating cable gaskets

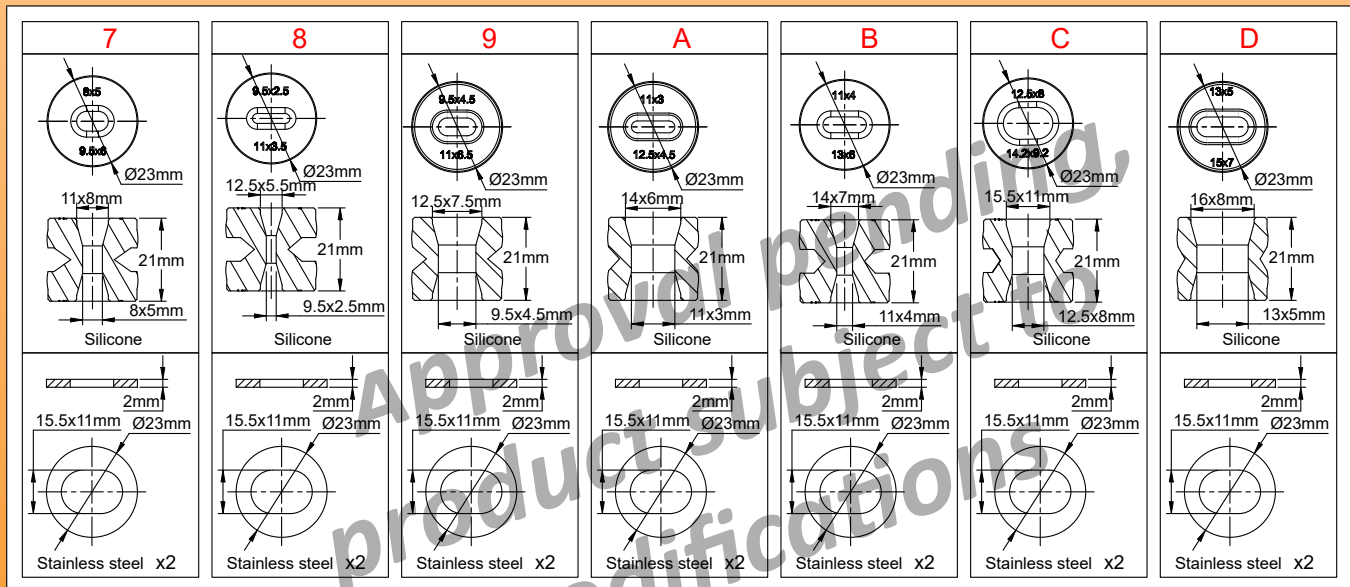

Main references codification

Y40-*.**-***

- * = cable gland gasket code on A side
- ** = cable gland gasket code on B side
- *** = Mounting legs option

Because of permanent improvement of our products, drawings, descriptions, features used on these data sheets are for guidance only and can be modified without prior advice

Stripping dimensions of the braided self-regulating cable, and stripping dimension of the power supply cable.

(More detailed instructions are available in the technical introduction)

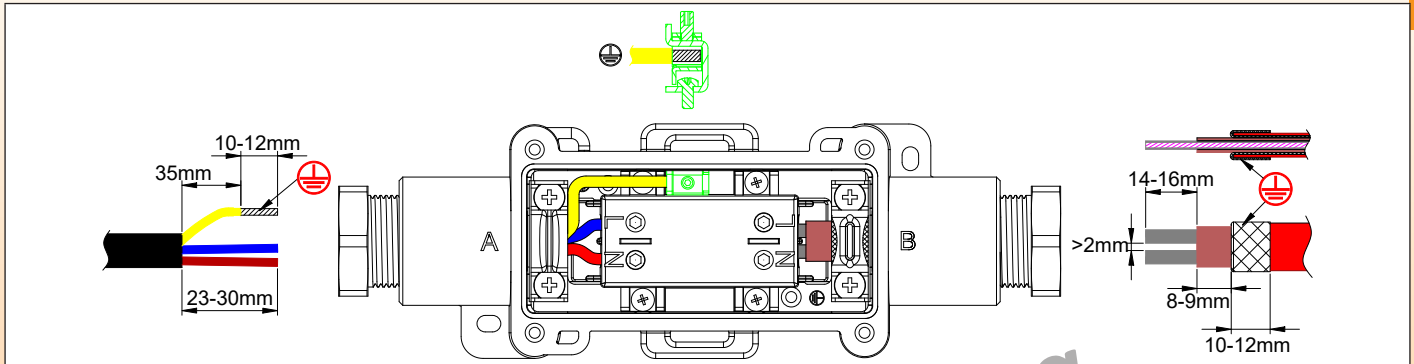

Model with one power supply cable and one heating cable

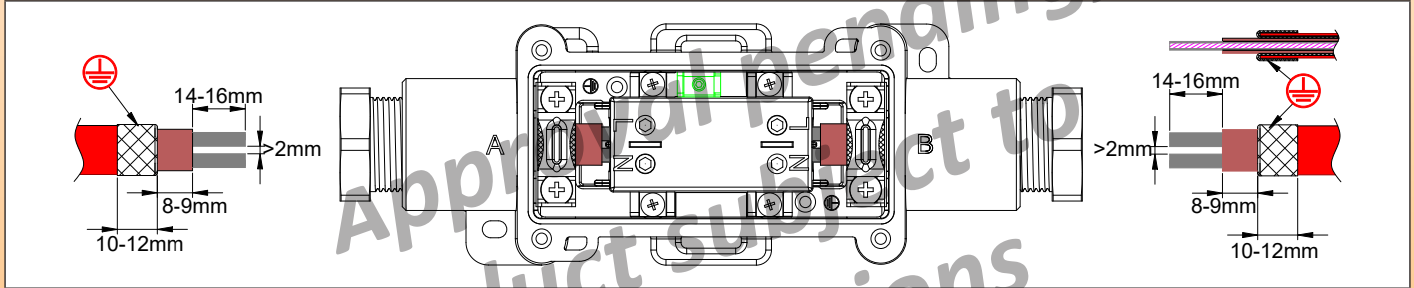

Model with two heating cable

Self-regulating cables assembly steps

<p>1</p>	<p>2</p> <p>* 6YTTL04</p>
<p>1: Cut the cable, slide on it the cable gland nut. Select the cable gland gasket with the compatible hole diameter and slide it on the cable</p>	<p>2: Remove external jacket on the requested length.</p>
<p>3</p>	<p>4</p> <p>* 6YTTL04</p>
<p>3: Cut the braid at the requested length. Don't unweave it.</p>	<p>4: Strip heating zone insulation at the requested length.</p>

* These exclusive tools are available in accessories section

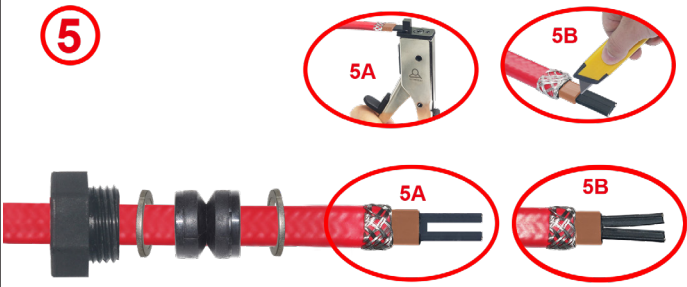
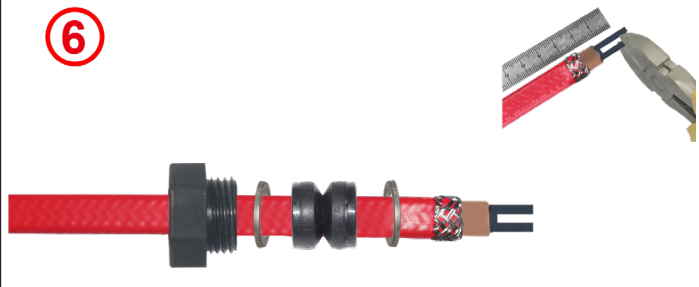
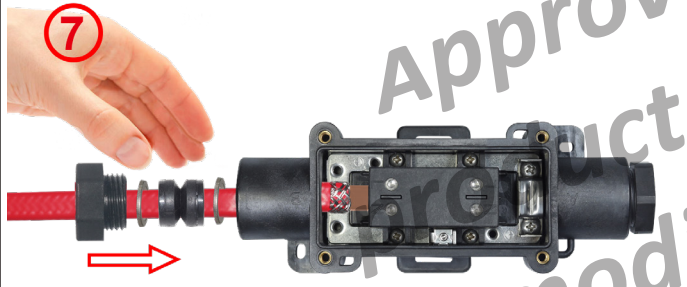
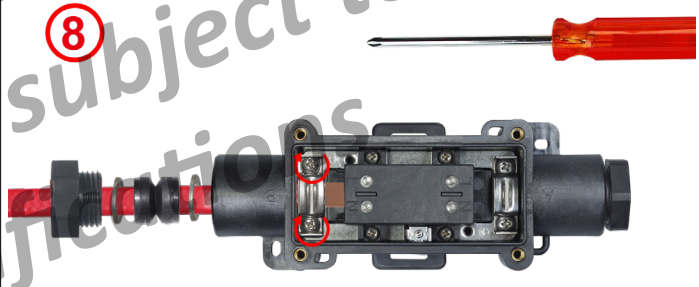
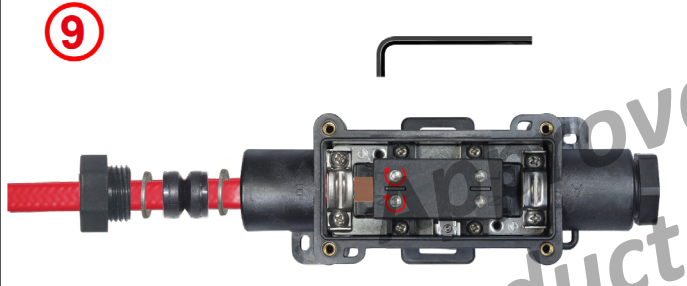
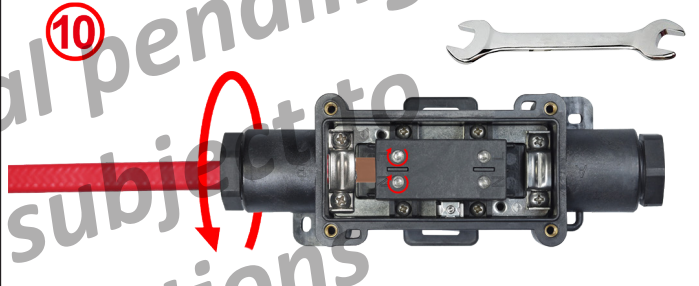
	
<p>5: Cut the heating zone between the 2 bus wires at the requested length. It can be made with a special tool (5A) or with a cutter (5B)</p>	<p>6: Adjust, if needed, the length of the bus wires.</p>
	
<p>7: Unscrew the saddle and remove it if necessary, then pass the cable through the cable gland. Slide the end of the self-regulating cable into the terminal block until it stops.</p>	<p>8: Tighten the saddle on the metal braid. Recommended tightening torque: 1.6 Nm.</p>
	
<p>9: Tighten the terminal screw until electrical contact is made with the conductor of the heating cable. Tightening torque is around 1.5 Nm. This tightening torque may vary depending on the thickness and hardness of the material of the semiconductor thermoplastic compound. If necessary, check the continuity with an ohmmeter by measuring the resistance between the two terminals N and L.</p>	<p>10: Slide the flat cable gasket into the cable gland and tighten the nut. Max. tightening torque 3N.m. If not yet made connect the other cable and close the lid.</p>





Round cable assembly steps

<p>1: Remove outer jacket on 24mm. Then strip the conductors on 10mm. Eventually, crimp cable shoes. Slide the cable gland nut on the cable. Select the compatible diameter gasket and slide it too on the cable.</p>	<p>2: Put the neutral and line wires inside the screw terminals and tighten them. Recommended torque 1.6 Nm.</p>
<p>3: Slide the ground wire under the ground terminal square washer and tighten the screw. Recommended torque 1.6 Nm.</p>	<p>4: Slide the round cable gasket into the cable gland and tighten the nut. Maximum tightening torque 3N.m.</p>

Assembly steps on pipe of stainless steel legs for thermal insulation.

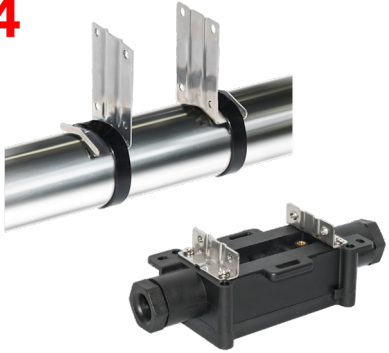
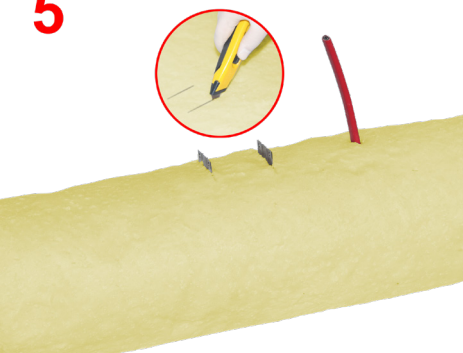
This bracket has been designed to simplify these assembly steps.

<p>1: Take the components of the mounting plate, which has 7 parts. The snap-on support (A), the two feet (B) and the four screws (C). Screw the bracket (A) on the bottom of the selected enclosure</p>	<p>2: Assemble the two feet with the four screws. Take the 2 legs (B) and the 4 screws (C)</p>	<p>3: Secure the plate and its legs to the tube with metal clamps (recommended), or if necessary, nylon ties. Screw the 2 legs on the bracket A and enclosure sub-assembly</p>

 <p>4</p>	 <p>5</p>	 <p>6</p>
<p>4: Separate the box from the two feet. It will be reassembled after installation of the insulation and any metal protective sheath. Assemble on the pipe with cable ties or stainless steel hose clamp</p>	<p>5: Place the heating cable on the tube following the recommendations of its manufacturer. Wrap the thermal insulation around the tube, leaving the end of the cable(s) out of the insulation at least 60mm from the two tabs. You just need to make a 50mm straight cut in the insulation to let each leg pass. Unscrew the bracket and enclosure sub-assembly and remove it</p>	<p>6: If the thermal insulation has a metal protective sheath, make two straight incisions of 4x42mm at a distance of 52mm to allow each of the two legs to pass. Provide the orifice(s) to exit the cables from the metal protection. Equip them with M25 cable glands with the appropriate gaskets for the dimensions of the cables. Close the metal sheath around the tube. Wrap insulation on the pipe, just making two straight cuts for the legs</p>
 <p>7</p>	 <p>8</p>	
<p>7: Seal the clearance between the metal tabs and the outer sheath of the piping with a silicone or elastomeric sealing resin. Wrap the mechanical protection around the insulation, making two straight cuts for the legs</p>	<p>8: Refit the ends of the legs with the 4 screws on the box.</p>	

Approval pending,
product subject to
modifications

Because of permanent improvement of our products, drawings, descriptions, features used on these data sheets are for guidance only and can be modified without prior advice

4 ways in line connection box in PPS for heat tracing cables, with insulation piercing terminals, for self-regulating cables

Because of permanent improvement of our products, drawings, descriptions, features used on these data sheets are for guidance only and can be modified without prior advice

4 ways in line	Insulation piercing	Wire gauge	Cables diameters		Type
		1~6mm ² 32A	 8 ~ 16 8 x 5 15 x 7		Y41

1. Red seal; 2. Stainless steel chain

Wall or surface mounting by the 2 holes on the enclosure (mounting option 0)

1. Red seal; 2. Stainless steel chain

Direct pipe surface mounting with short PPS legs (mounting option 1)

1. Red seal. 2. Stainless steel chain

Pipe surface mounting with short stainless steel legs bracket, for 10mm thermal insulation (Mounting option 2)



Explosion proof connection boxes

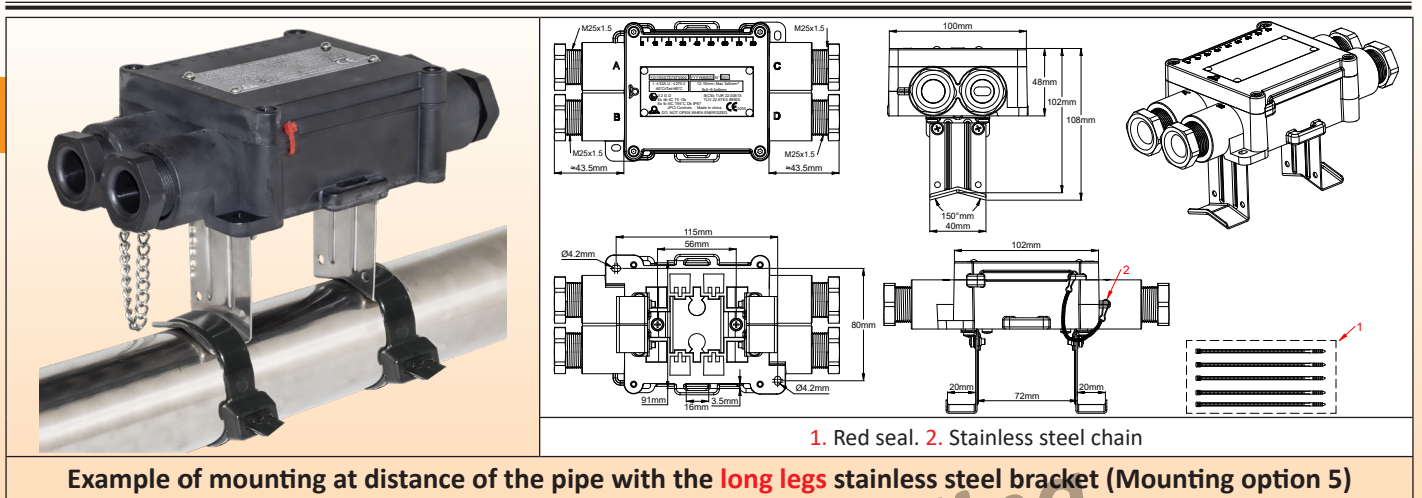

Example of mounting at distance of the pipe with the **long legs** stainless steel bracket (Mounting option 5)

Applications

This box is used to connect a **power supply cable to 3 self-regulating cables**. It can be mounted flat on a surface, or on a pipe, including with insulation up to 50mm thick.

Pipe mounting brackets are screwed on rear side.

The terminal blocks are easily accessible and **the connection is very simple, in particular for flat self-regulating cables with metallic protective braid**.

They can be used in domestic and industrial environments as well as in explosive atmospheres.

They are particularly suited to industrial or saline environments, indoors or outdoors.

Approvals:

- **Industrial applications in electrical heat tracing** according to IEC 62395.

- **Applications in explosive environments:** these boxes are approved as Increased safety "e": (Device preventing the production of sparks at the connections by ensuring the necessary mechanical support and insulation).

Optional accessories:

- Cable glands can be fitted with special bolts for use with electrical cable protection tubes with Atex approvals.

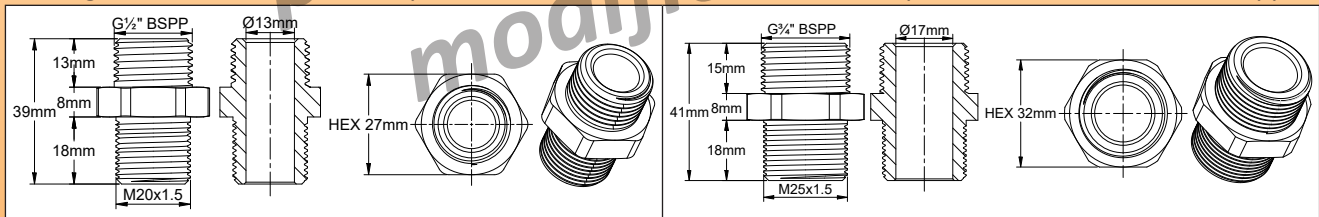

Protection against gaz: Ex II 2G Ex cb IIC T5 Gb

Protection against dust: Ex II 2D Ex tb IIIC T95°C Db

Certificates: ATEX: TÜV 22 ATEX 8896 X; IECEx: IECEx TUR 22.0061 X; CCCEX: ??

Main features

Material: Fiber glass reinforced PPS, with very high mechanical strength. Superior UV and very cold temperature resistance.

Waterproof grade: IP67 and IP69K (high pressure hot water washing)

Shocks resistance: The highest, IK10 (Cable gland not included).

Mounting:

- **Wall mounting:** 2 wall mounting lugs allow the mounting on a flat surface. Holes distance 112 × 45mm.

- **Pipe mounting without offset:** Two removable PPS legs are supplied as standard and allow mounting on a tube using a nylon tie or metal clamp. The distance from the tube limits the heating of the box.

- **Pipe mounting with 10mm offset:** Two removable stainless steel legs are supplied as standard and allow mounting on a tube using a nylon tie or metal clamp. The distance from the tube limits the heating of the box.

- **Pipe mounting with 50mm offset:** Two removable stainless steel legs allow the installation of a thermal insulation and its protection before snapping-on the box on it and making electric connections (Available as an accessory, see catalogue page on 6YTQW parts).

Terminals:

- The terminals are piercing the insulation layers with a multiple chisels blade and retain the contact pressure by means of an elastic blade (patented).

- **These terminals are designed to receive self-regulating heating cables with any distance between the bus wires between 2mm and 10mm.**

- These terminals can also possibly be used for conventional conductors of power supply cables.

- All terminals are protected against loosening by vibration or thermal shock.

- The mechanical tightening of the cable is ensured by a screwed metal saddle, usable on round or flat cable.

This patented saddle also ensures the earthing of the metal braid of the heating cables.

- Wire gauge: $3 \times 1 \text{ mm}^2$ to $3 \times 6 \text{ mm}^2$.
- Maximum permissible intensity: 32A 250V.

Interconnection: The neutral terminals (N) are internally connected by a jumper and so are the Line (L) terminals.

Cables outlet: with M25 cable glands, with 50 shore silicone gaskets.

Inviolability: The case can receive one or two seals (Supplied with 5 red nylon ties for use in the sealing holes).

Ambient temperature limits: -60 to +50° C. (-76°F; +122°F)

Maximum linear power of heating cable: 75W / m.

Maximum intensity: 32A per terminal.

Easy assembly: Assembly is made with full access to terminals when cover is removed. Mounting on wall or pipe can be made with cover removed or cover assembled closed without being hindered by the tightening link

Available round cable gaskets

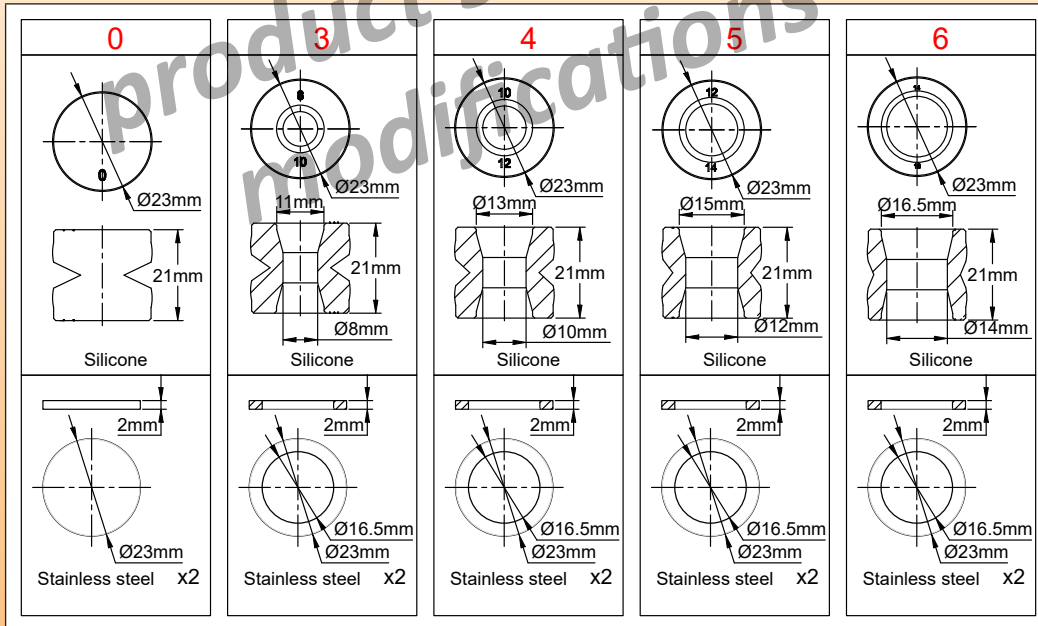

Available flat heating cable gaskets

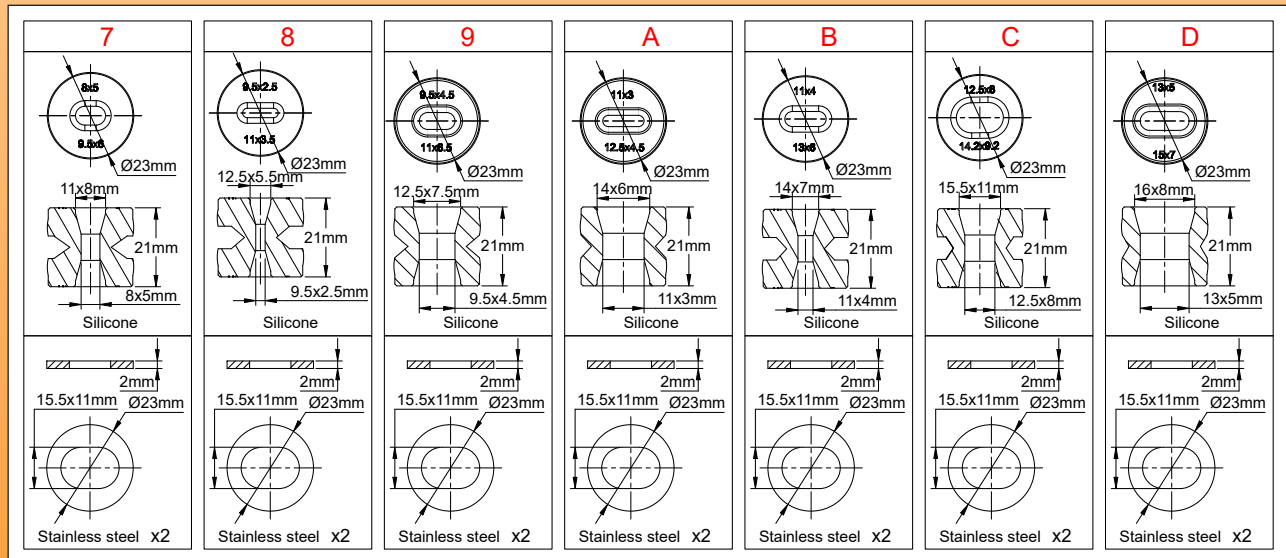

Main references codification

Y41-*-*-*-*-*

- * = cable gland gasket code on A side
- ** = cable gland gasket code on B side
- *** = cable gland gasket code on C side
- **** = cable gland gasket code on D side
- ***** = Mounting legs option

Because of permanent improvement of our products, drawings, descriptions, features used on these data sheets are for guidance only and can be modified without prior advice

Stripping dimensions of the braided self-regulating cable, and stripping dimension of the power supply cable.

(More detailed instructions are available in the technical introduction)

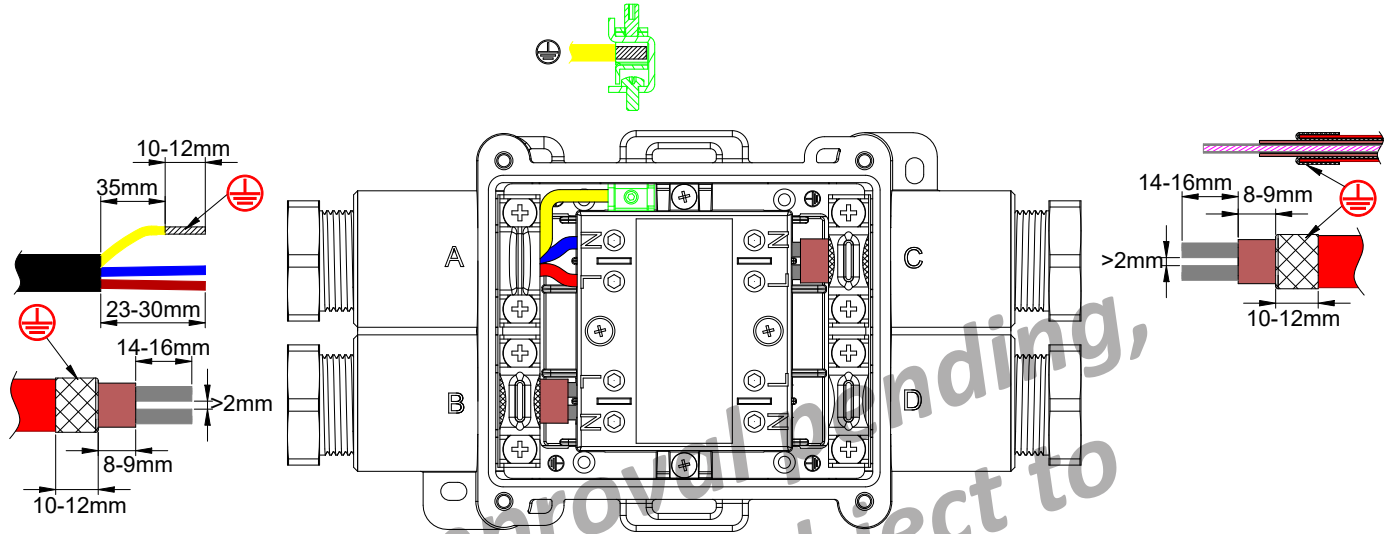

Model with 2 heating wires and one power supply cable

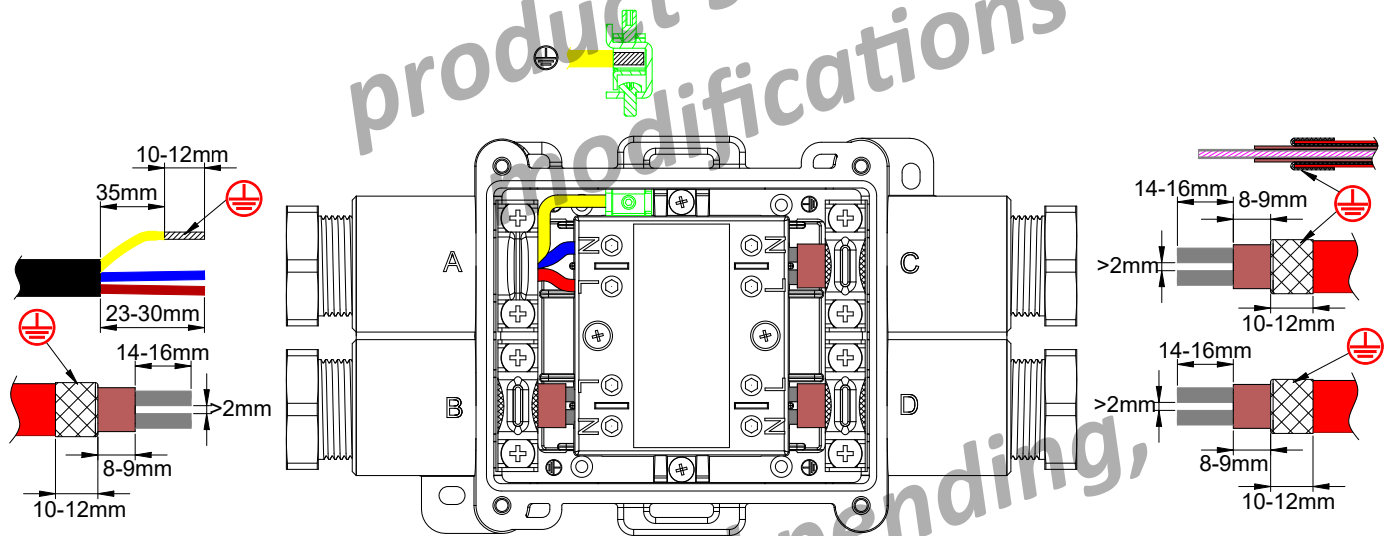

Model with 3 heating wires and one power supply cable

Self-regulating cables assembly steps

1

1: Cut the cable, slide on it the cable gland nut. Select the cable gland gasket with the compatible hole diameter and slide it on the cable

2



2: Remove external jacket on the requested length.

* These exclusive tools are available in accessories section

Explosion proof connection boxes

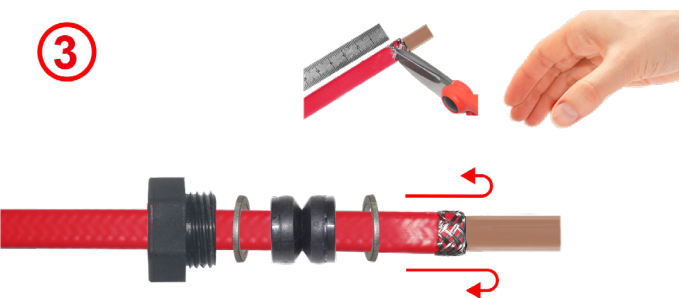
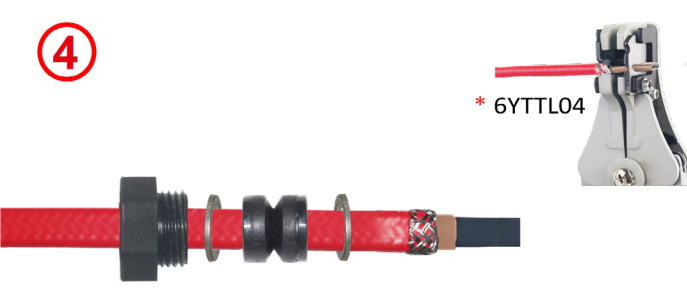
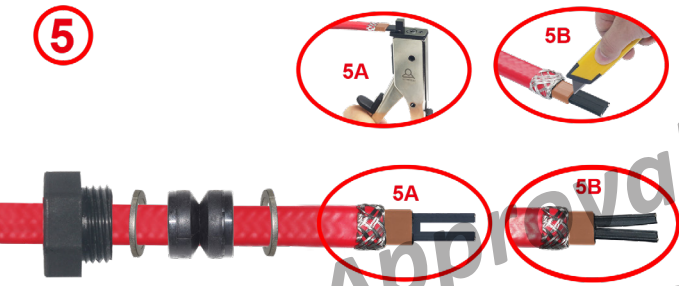

Because of permanent improvement of our products, drawings, descriptions, features used on these data sheets are for guidance only and can be modified without prior advice

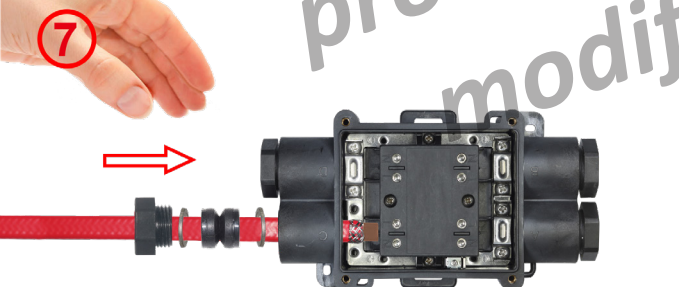
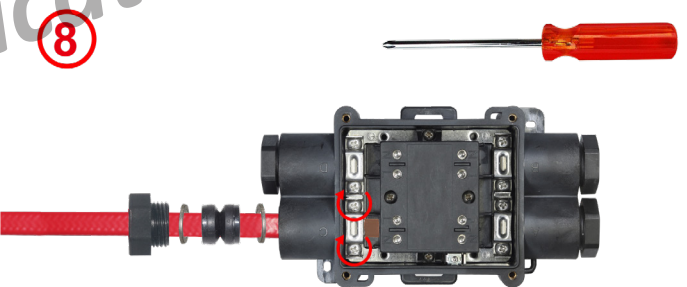
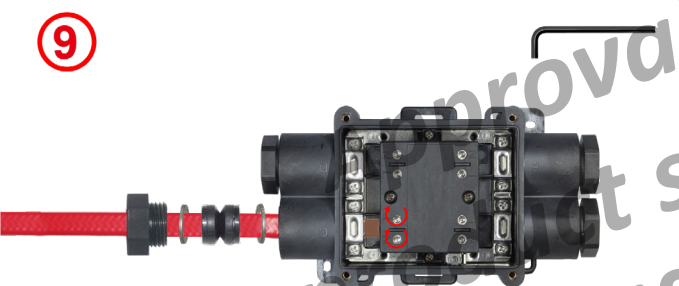
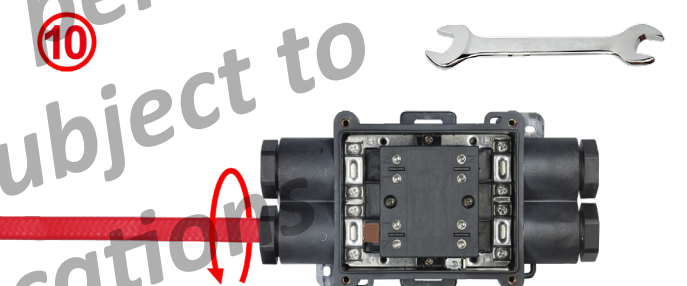
 <p>3</p>	 <p>4</p> <p>* 6YTTL04</p>
<p>3: Cut the braid at the requested length. Don't unweave it.</p>	<p>4: Strip heating zone insulation at the requested length.</p>
 <p>5</p> <p>5A 5B</p>	 <p>6</p>
<p>5: Cut the heating zone between the 2 bus wires at the requested length.</p>	<p>6: Adjust, if needed, the length of the bus wires.</p>
 <p>7</p>	 <p>8</p>
<p>7: Unscrew the saddle and remove it if necessary, then pass the cable through the cable gland. Slide the end of the self-regulating cable into the terminal block until it stops.</p>	<p>8: Tighten the saddle on the metal braid. Recommended tightening torque: 1.6 Nm.</p>
 <p>9</p>	 <p>10</p>
<p>9: Tighten the terminal screw until electrical contact is made with the conductor of the heating cable. Tightening torque is around 1.5 Nm. This tightening torque may vary depending on the thickness and hardness of the material of the semiconductor thermoplastic compound. If necessary, check the continuity with an ohmmeter by measuring the resistance between the two terminals N and L.</p>	<p>10: Slide the flat cable gasket into the cable gland and tighten the nut. Max. tightening torque 3N.m. If not yet made connect the other cable and close the lid.</p>

* These exclusive tools are available in accessories section

Round cable assembly steps

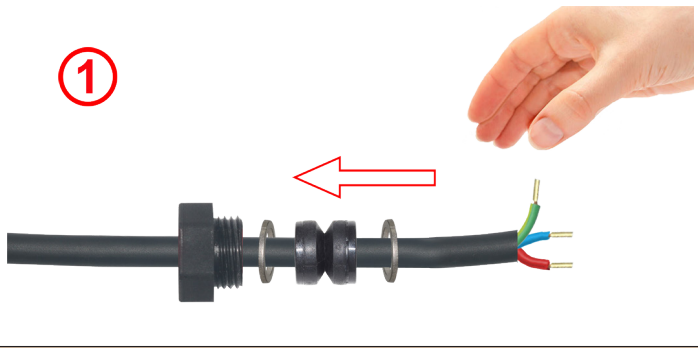
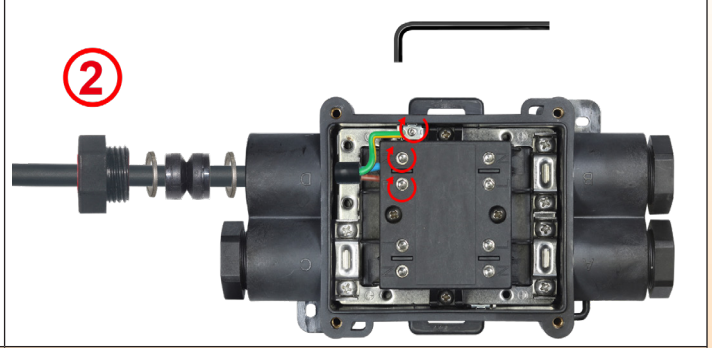
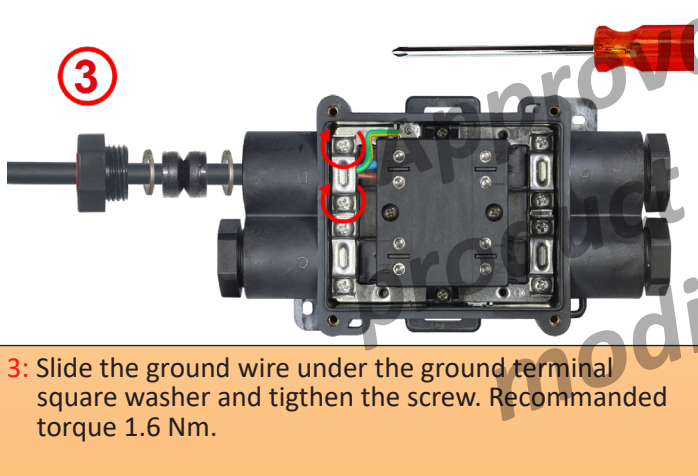
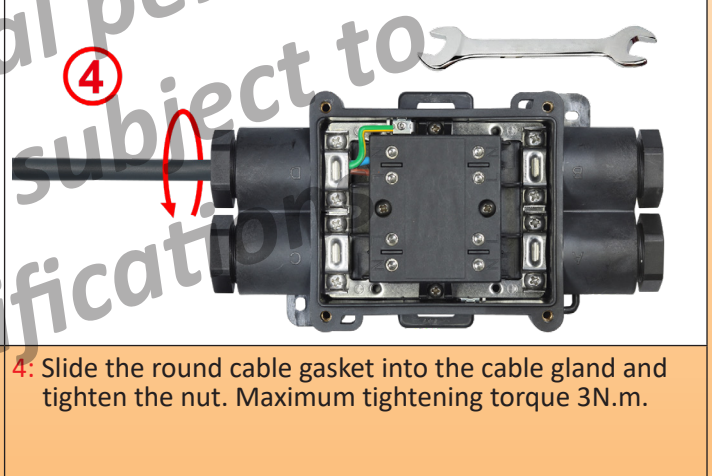
	
<p>1: Remove outer jacket on 24mm. Then strip the conductors on 10mm. Eventually, crimp cable shoes. Slide the cable gland nut on the cable. Select the compatible diameter gasket and slide it too on the cable.</p>	<p>2: Put the neutral and line wires inside the screw terminals and tighten them. Recommended torque 1.6 Nm.</p>
	
<p>3: Slide the ground wire under the ground terminal square washer and tighten the screw. Recommended torque 1.6 Nm.</p>	<p>4: Slide the round cable gasket into the cable gland and tighten the nut. Maximum tightening torque 3N.m.</p>

Approval pending,
product subject to
modifications

Because of permanent improvement of our products, drawings, descriptions, features used on these data sheets are for guidance only and can be modified without prior advice



Section 6

Mechanical thermostats inside housing, for **ambient temperature measurement, or with remote probe**



The advantages of mechanical thermostats

- Inexpensive
- Simple to use without the need for specially trained users.
- Simple connection, usually with only 2 conductors.

M20x1.5 Thermostats for mounting in cable glands holes or threads, for boxes external ambient temperature control



Because of permanent improvement of our products, drawings, descriptions, features used on these data sheets are for guidance only and can be modified without prior advice

Thread	Body diameter	Wire gauge	Sensors	Body material	Type
M20 × 1.5	Ø18.2 × 15mm	0.5mm ² (AWG24)	Disc thermostat	Anodized aluminum	49JB

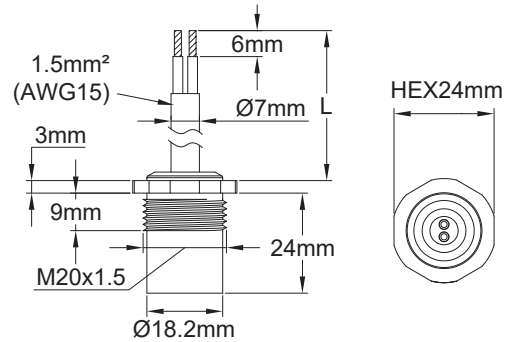

Through cabinet wall assembly versions

In a M20x1.5 thread	In a 20mm diameter drill	In a M20x1.5 thread (gasket in red)	In a 20mm diameter drill (Nut in green)

Applications

These fixed setting thermostats have been designed to be mounted in holes dia. 20mm (With a lock nut and a gasket) or in M20x1.5 threads (With a gasket), originally intended for mounting cable glands on connection boxes or control boxes. **They allow to easily install an ambient temperature control on these boxes, usually used as an anti-freeze function.** The ambient temperature measurement is then made outside, 15mm from the wall, and the system is fully waterproof.

Main features

- Housing:** Black anodized aluminum with M20x1.5 thread.
- Ingress protection:** IP66.
- Connection:** 1.5mm² two-conductor cable (AWG15), 300V insulation.
- Temperature set point:**
Open: 10 ± 3 °C (Heating off).
Close: 4 ± 3 °C (Heating on).
Other temperatures on request, consult us.
- Electric rating:** 16A 250V, 10,000 cycles.
- Accessories:**

M20 x1.5 Nylon nut		66NDM20545H25
70 shore NBR gasket		66JPN18518265

References

Cable length (L)			
300mm	1m	2m	3m
49JBDJ01006KFRF8	49JBDJ01006KFR18	49JBDJ01006KFR28	49JBDJ01006KFR38

Note: Some versions of these thermostats for applications to control ambient temperature in hazardous areas (dust or gas) are described in the catalogue 4. The thread is then M22x1.5 instead of M20x1.5, and products family reference becomes 4V.

2 parallel ways connection box for heat tracing cables, with 2 pilot lights and built-in antifreeze thermostat



2 parallel ways	Wall mounting	Wire gauge	Cables diameters		Type
		1~2.5mm ²			Y22

Applications

These boxes are particularly intended for the automatic start of **antifreeze heating of small installations**. They allow to connect a power supply cable to a conventional or self-regulating heating cable. In these models, the over-molded bimetallic, fixed-temperature thermostat is thermally isolated from the wall on which it is mounted, and its measurement surface is mechanically protected by a grid. It is located in front of the cabinet in order to be in a natural area for the circulation of ambient air. The box must therefore be mounted in a location representative of the ambient temperature around the installation to be protected. **The two indicator lights allow to quickly check the operating status.**

Main features

Mounting: Wall, by external side brackets. These tabs can be folded inwards.

Protection: IP65 (IK03 on thermostat guard, IK10 the rest of the housing)

Material: ABS-PC black glass-fiber reinforced

Screws: Stainless steel, captives

Thermostat calibration: Contact opens at 10°C (stops heating), closes at 4°C (starts heating)

Output: 2 Cable glands M20, PA6, IP66.

Comes with two sets of gaskets in NBR 70 shore for round cable from 8 to 12mm, and one set for oblong cable up to 6 × 13mm

Electrical rating: Single pole, 16A 250V (10.000 cycles).

Pilot lights: Allow to visualize the power supply and thermostat contact position (230V line and neutral power supply is mandatory for the pilot lights).

Identification: The cover has a 20x40mm recess for a riveted stainless-steel identification plate or a sticker.

Customization: Laser printing on the stainless-steel identification plate or personalized label.

Connection: Built in 4mm² screw terminal block.

Options:

- Other calibration temperatures.
- Models without pilot lights.

Reference

Y22D9J01006USUS0



Applications

This box allows to connect, with a good IP65 ingress protection, 2 rounds or flat heating cable to a round power cable or providing at the same time the continuity of the power line.

The built-in disc thermostat provides the anti-freeze function.

It can be mounted on a flat surface, or on a pipe.

Terminals positions provide easy access, wiring is simple, including for braided heating cables.

Compatible with all types of flexible heating wires, round or flat.

Main features

Material: Polyamide 66 black, 90mm × 67mm × 36mm (Cable glands not included). Excellent UV resistance.

Waterproof grade: IP65

Thermostat: rating 16A 230V, open by temperature rise at 10°C ±3°C, close at 4°C±3°C (Other temperatures on request)

Mounting: 2 removable wall mounting bracket, holes distance 96mm. Pipe mounting with cable tie also possible, by using the 2 rings located on the side of the box

Terminals:

- Screw terminals with captive toothed square washers accepting rigid or flexible conductors.
- The mechanical tightening of the cable is ensured by a screwed metal saddle, usable on round or flat cable.

This patented saddle also ensures the earthing of the metal braid of the heating cables.

- Wire gauge: 3 × 1mm² to 3 × 2.5mm²
- Maximum permissible intensity: 16A 250V

Cables outlet: with M24 cable glands, with 70 shore NBR gaskets (Silicone is available on request).

- Maximum diameter of round cables: 8; 12 or 14mm depending on the gaskets installed.

- Limit sizes of oblong cables:

- from 8 × 5 to 9.5 × 6mm
- from 9.5 × 2.5 to 11 × 3.5mm
- from 11 × 4 to 13 × 6mm
- from 12.5 × 8 to 14.2 × 9.2mm

For more information about tightening possibilities on round and oblong cables, see the catalogue page on 6YTP cable glands.

Safety sealing: supplied with 5 red plastic ties for use in the sealing holes

Easy assembly: Assembly is made with full access to terminals when cover is removed. Mounting on wall or pipe can be made with cover removed or cover assembled.

Accessories: Stainless steel bracket for mounting distant from the pipe, see accessories page 6YTQT.

Options: Model for 3 heating wires without power supply cable and model for one heating wire and 2 power supply cables.

Main part numbers

Y261SS06103004300	Includes a set of gaskets for round cables, 2 sets of gaskets for oblong cables and 2 metal tabs for pipe mounting		
References	Seals on side A*	Seals on side B*	Seals on side C*
Y261PFF610304300	Silicone seal for round cable dia. 8mm max.	Silicone seal for oblong cable max. size 13x6mm	Silicone seal for oblong cable max. size 13x6mm
Y261KNN610304300	NBR seal for round cable dia. 8mm max.	NBR seal for oblong cable max. size 13x6mm	NBR seal for oblong cable max. size 13x6mm
Y261PSS610304300	Silicone seal for round cable dia. 8mm max.	Set of Silicone seal for oblong cables max. size 9.5x6 ; 11x3.5; 13x6 and 14.2x9.2mm.	Set of Silicone seal for oblong cables max. size 9.5x6 ; 11x3.5; 13x6 and 14.2x9.2mm.
Y261KXX610304300	NBR seal for round cable dia. 8mm max.	Set of NBR seals for oblong cables max. size 9.5x6 ; 11x3.5; 13x6 and 14.2x9.2mm.	Set of NBR seals for oblong cables max. size 9.5x6 ; 11x3.5; 13x6 and 14.2x9.2mm

* Silicone seals recommended for ambient temperature higher than 80°C



3 parallel ways connection box for heat tracing cables, with built-in antifreeze thermostat

Stripping dimensions of round and oblong cables

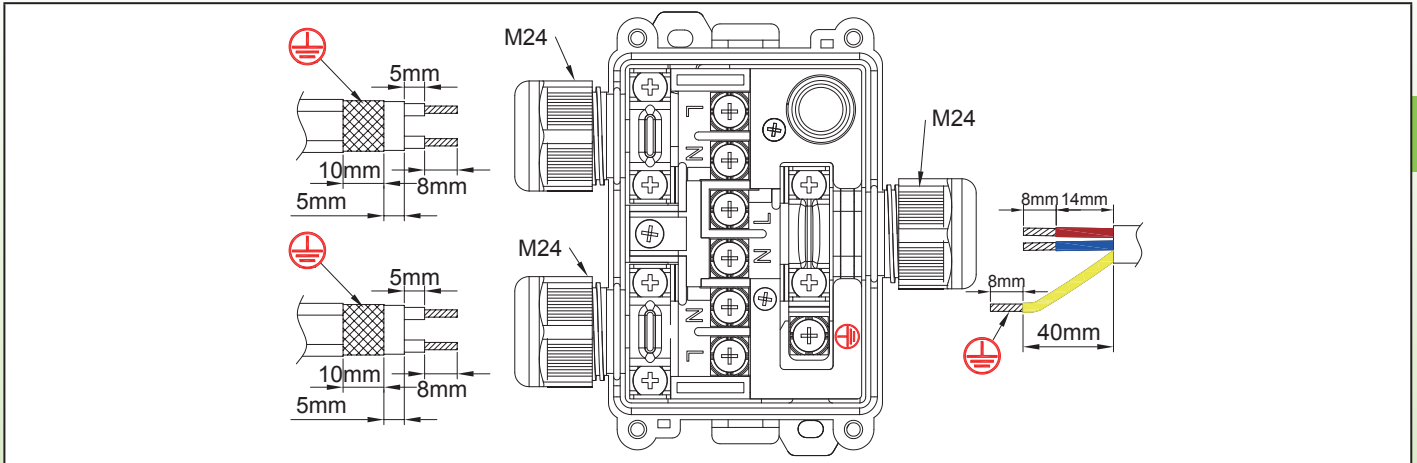

Self-regulating cables assembly steps

(More details on the different methods of preparing termination for various types of cables are available in the technical introduction).

<p>1: After selecting the cable gland seal to the recommended size for the cable type, pass the heating cable through the gland nut and its seal.</p>	<p>2: Strip the outer jacket of the heating cable to the required length.</p>
<p>3: Cut the braid to the requested size</p>	<p>4: Strip the insulating jacket around the heating part to the required length.</p>
<p>5: Cut the heating part between the two bus wires to the required length.</p>	<p>6: Strip the two bus wires over the required length.</p>

* These exclusive tools are available in accessories section

Because of permanent improvement of our products, drawings, descriptions, features used on these data sheets are for guidance only and can be modified without prior advice

3 parallel ways connection box for heat tracing cables, with built-in antifreeze thermostat



Because of permanent improvement of our products, drawings, descriptions, features used on these data sheets are for guidance only and can be modified without prior advice

<p>7: If necessary, cut the stripped bus wires to length.</p>	<p>8: Unscrew and remove the saddle, unscrew and remove the terminal screws if necessary, then pass the cable through the cable gland.</p>
<p>9: Put the bus wire and the braid at the place they will be tightened. Tighten the terminal block screws on the bus wires. Recommended torque 1.2 Nm</p>	<p>10: Replace the saddle and tighten it on the metal braid. Recommended torque 1.2 Nm</p>
<p>11: Slide the flat cable gasket into the cable gland and tighten the nut. Maximum torque 3Nm. Connect any other cables and close the lid.</p>	

Round cable assembly steps

<p>1: Remove outer insulation on round cable as requested by drawing. Eventually, crimp cable shoes. Slide the cable gland nut on the cable. Select the compatible diameter gasket and slide it on the cable</p>	<p>2: Put the neutral, line and ground wires inside the screw terminals and tighten them. Recommended torque 1.2 Nm</p>



3 parallel ways connection box for heat tracing cables, with built-in antifreeze thermostat

Because of permanent improvement of our products, drawings, descriptions, features used on these data sheets are for guidance only and can be modified without prior advice

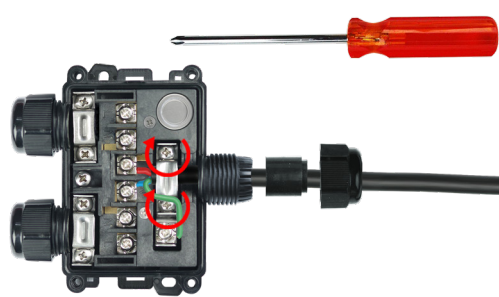
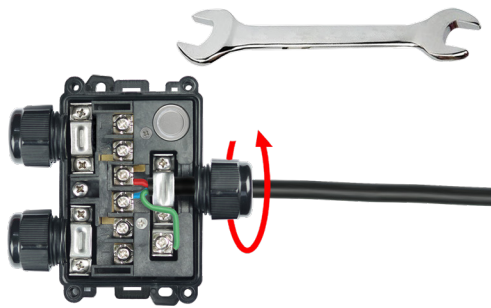
<p>3</p> 	<p>4</p> 
<p>3: Tighten the saddle screw. Recommended torque 1.6 Nm</p>	<p>4: Slide the round cable seal into the cable gland and tighten the nut. Maximum torque 3N.m.</p>

“Pigtail” bulb room thermostat, with built-in pilot light and 2 M20 cable glands for heat tracing application



Enclosure	Type	Operation	Contact	Measurement	Ranges °C	Types
IP55	Control	Mechanical	SPNC	Ambient		Y0D8 & Y0D9
Material						
PC-ABS						

Y0D8: External adjustment

Y0D9: Internal adjustment

Example of wall mounting model connected on Y25 connection boxes for antifreeze protection of livestock waters



Example of assembly on Y29 connection box with pipe mounting leg



Because of permanent improvement of our products, drawings, descriptions, features used on these data sheets are for guidance only and can be modified without prior advice

“Pigtail” bulb room thermostat, with built-in pilot light and 2 M20 cable glands for heat tracing application



Applications

Ambient temperature control in professional premises where good protection against liquid splashes or dust is requested.

Output with 2 cable glands, allowing of heat tracing cables for freeze protection.

The connection of one heating cable can be done directly. For the connection of several heating cables, it is necessary to go through an intermediate box of types Y25, Y26, Y28, Y29 (See pages of these products)

Main features

Housing: Reduced height, IP44, black PC-ABS fiberglass reinforced, UL94V0. High impact and UV resistance. 2 removable wall mounting lugs.

Cable input: Two M20 cable glands. Mounting of cable glands can be modified in 3 positions. **Special cable glands for oblong heat tracing cables are available on request. Available models are described on pages of 6YTP products**

Set point adjustment: By °C printed knob for external adjustment models, by screw driver and printed dial on internal adjustment models. °F values available as an option.

Sensing element: Liquid filled “pigtail” bulb, mounted on the side of plastic housing

Adjustment ranges: 4-40°C (40-105°F).

Electrical connections: On screw terminals. (It is possible to connect 2 wires 1.5mm² on each terminal).

Mounting: Wall mounting, by two side lugs with holes for dia. 4mm screws, 69mm distance.

This thermostat can be mounted directly on the rear side of pipe mounting connection boxes type Y29.

Contact: SPNC (open on temperature rise).

Pilot light: Neon, 230V, standard in red, parallel connection on the load

Electrical rating, resistive loads: 16A 250V, 50 ~60Hz.

Minimum storage temperature: -35°C (-30°F)



Maximum ambient temperature: 60°C (140°F)

Selection of some part numbers with cable gland seals for round cables *

Temperature ranges °C (°F)	Internal adjustment**	External adjustment**	Differential	Max temperature on bulb
4-40 (40-105)	Y0D9KD104040QB3J	Y0D8KD104040QB3J	1±0.5°C (1.8±1°F)	60°C (140°F)

* These products also exist with bulb and capillary sensing element: replace Y0D by Y0A in the reference. See the catalogue N°2 for the technical data sheets of all models and temperature ranges.

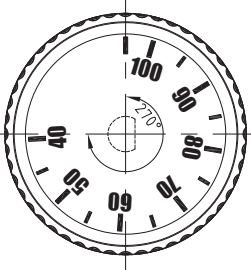
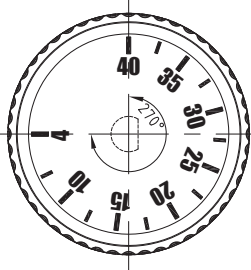

** °F printing: replace last character (J) by K.

Knob printings		*Models with bulb and capillary sensing element	
°F Printing	°C Printing	Y0A8	Y0A9
40-105°F	4-40°C		
			

Because of permanent improvement of our products, drawings, descriptions, features used on these data sheets are for guidance only and can be modified without prior advice

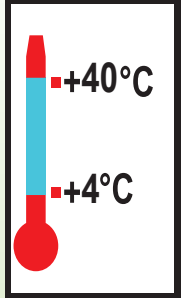
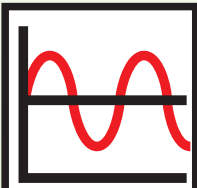
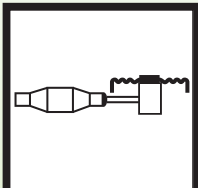
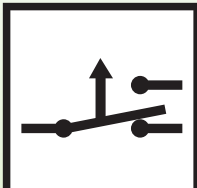

“Pigtail” bulb room thermostats with metal housing, for heat tracing

Enclosure	Type	Operation	Contact	Measurement	Ranges °C	Types
IP65, IK10	Control	Mechanical	SPDT	Ambient		Y1A8G & Y1B8G
Material						
Aluminum						

Y1B8G: External adjustment (With pilot light)

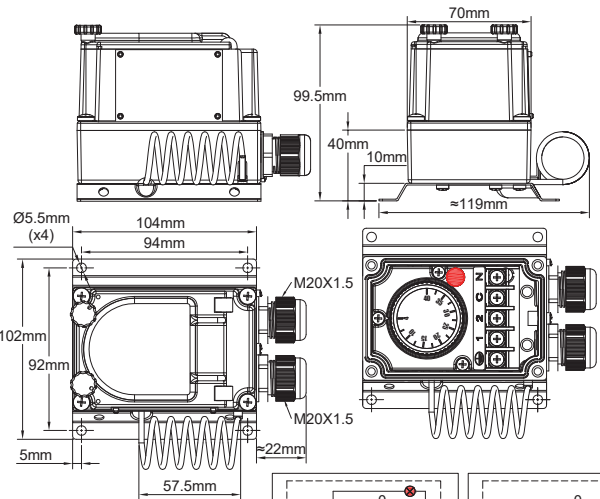

Y1A8G: Internal adjustment (Without pilot light)

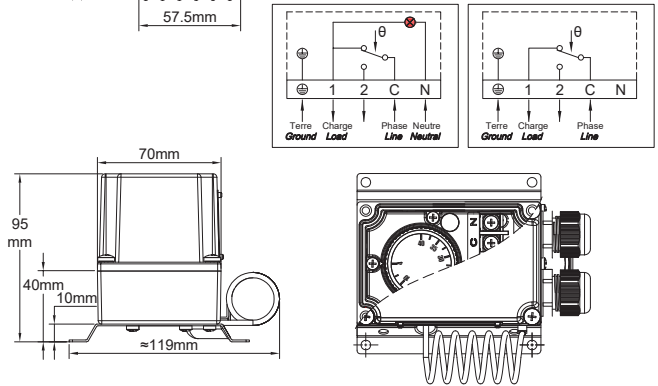

Example of assembly on two heat tracing cables of one Y1B2P, in combination with Y29 connection box



Example of assembly on two heat tracing cables, with Y27 connection box, for steel pipe antifreeze protection

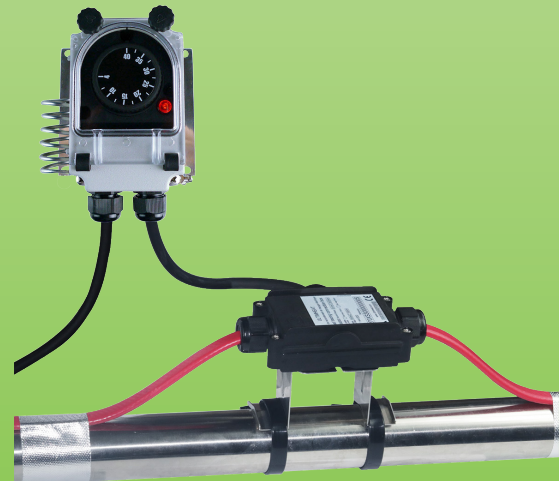

Because of permanent improvement of our products, drawings, descriptions, features used on these data sheets are for guidance only and can be modified without prior advice



“Pigtail” bulb room thermostats with metal housing, for heat tracing

Applications

- Heavy duty industrial environments. Robust and durable electromechanical system. Insensitive to voltage variations.
- Outdoor antifreeze temperature control of heaters and heat tracing cables.
- Wall mounting for indoor or outdoor temperature control of cold rooms.
- Temperature control of industrial or commercial premises.
- Green houses and livestock stables temperature control.

Housing: Aluminum, IP65, IK10. Mounted on a SUS304 stainless steel wall mounting plate which keeps the temperature sensing element away from the wall. Grey RAL7032 epoxy painting. Stainless steel captive cover screws. Captive aluminum lid.

Set point adjustment ranges: 4-40°C (40-105°F)

Set point adjustment: By °C printed knob. All types have an adjustable rotation limit system located inside the knob that allows reducing the set point adjustment span. Types with external adjustment have a transparent window. This device allows seeing the pilot light and the knob position. °F values are available as an option.

Action: Temperature control.

Sensing element: Liquid filled “pigtail” bulb, mounted on the side of plastic housing.

Electrical connections: Inside, on screw terminal connection block.

Earthing: Internal and external screw terminal.

Pilot light: Allow to visualize thermostat contact output position. Standard for all models with transparent window. Non standard and on special request only for models with plain aluminum cover.

Cable input and output: Two M20 cable glands, Black PA66.

Mounting: Wall mounting, by 4 holes for screws dia. 4 to 5mm, 94 × 92mm distance.

Identification: Metallic identification label, riveted.

Contact: SPDT

Electrical rating, resistive loads:

16A 250V, 50 ~60Hz: >100000 cycles.

Electrical rating, inductive loads:

- Open on temperature rise contact (C-1): 6A 250V, 50 ~60Hz: >100000 cycles

- Close on temperature rise contact (C-2): 0.6A 250V 50 ~60Hz: >100000 cycles.

Minimum storage temperature: -35°C (-30°F)

Maximum ambient temperature: 60°C (140°F)



Options: Models with bulb and capillary for distant measurement

For more technical information about the thermostat used inside this housing, see 8G thermostat technical data sheet in the catalog number 1.

References principales

Temperature adjustment ranges °C (°F)	References with external adjustment	References with internal adjustment	Differential °C (°F)
4-40°C (40-105°F)	Y1B8G4040AQ30001J	Y1A8G4040AQ30001J	4±2°C (7.2±3.6°F)

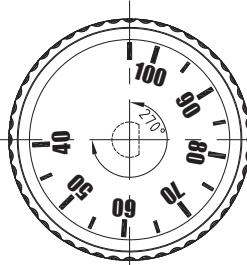
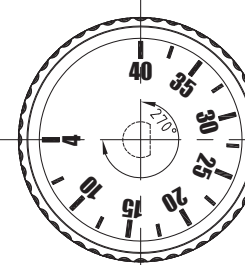

°F printing: replace last character (J) by K

Knob printings		Similar products (For more information these models, see the catalogue number 2, second edition)	
°F Printing	°C Printing	Y1R8G	Y118G
40-105°F	4-40°C	Thermostat with distant sensor and internal adjustment	Thermostat with distant sensor and adjustment under window
			

Update 2025/06/27

“Pigtail” bulb room thermostats for heat tracing

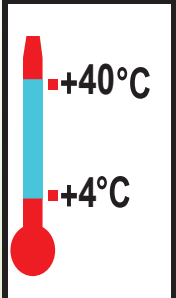
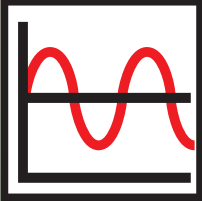
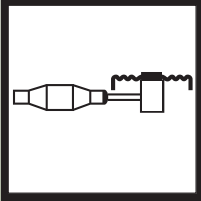
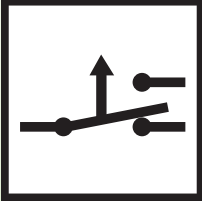

Enclosure	Type	Operation	Contact	Measurement	Ranges °C	Type
IP66 IK10	Control	Mechanical	SPDT	Ambient		YF7GNC
Material						
PA66 & PC						

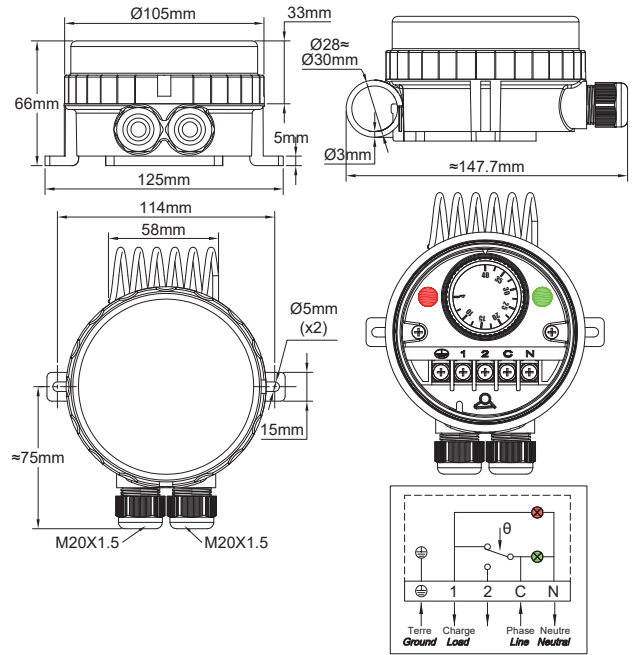

Example of assembly on 3 or more heat tracing cables, in combination with Y25 connection boxes



Example of assembly on 2 heat tracing cables, with one Y29 connection box, for metal pipe antifreeze protection

Because of permanent improvement of our products, drawings, descriptions, features used on these data sheets are for guidance only and can be modified without prior advice



“Pigtail” bulb room thermostats for heat tracing

Applications

- Equipment requesting a very strong resistance to water ingress. The transparent cover allows to visualize the set point and the 2 pilot lights. The mechanical temperature measurement is heavy duty and insensible to voltage changes.

- Outdoor antifreeze temperature control of heaters and heat tracing cables.

Wall mounting for indoor or outdoor temperature control of cold rooms.

- Temperature control of industrial or commercial premises.

- Green houses and livestock stables temperature control.

Housing: Protection class IP 66 upon EN 60529 (waterproof spray water under high pressure and sea splashes, totally dust tight). Body in black PA66, fiber glass reinforced. The transparent polycarbonate cover can be unscrewed by hand, but it is also possible to use a hook spanner. Mechanical impact resistance: IK10. High UV resistance.

Set point adjustment: By °C printed knob. All types have an adjustable rotation limit system located inside the knob that allows reducing the set point adjustment span. °F printed knobs available as an option.

Action: Temperature control. On-Off action

Sensing element: Liquid filled “pigtail” stainless steel bulb, mounted on the top side of the plastic housing.

Pilot lights: One pilot light visualizes the thermostat contact output position. The other visualizes the power supply input. Phase and neutral electrical line supply are mandatory for these pilot lights.

Set point adjustment ranges: 4-40°C (40-105°F)

Cable input and output: Two M20 cable glands, built-in black PA66.

Electrical connections: Inside, on screw terminal connection block. It is possible to connect 2 wires 1.5mm² on each terminal.

Earthing: Internal screw terminal.

Mounting: Wall mounting, by 2 legs with holes for screws dia. 4 to 5mm, 114mm distance

Identification: Identification label on backside.

Contact: SPDT

Electrical rating, resistive loads:

16A 250V, 50 ~60Hz: >100000 cycles,

Minimum storage temperature: -35°C (-30°F)

Maximum ambient temperature: 60°C (140°F)



Options: Models with remote temperature sensor

For more technical information about the thermostat mechanism used in this enclosure, see the 8G thermostat technical data sheet in catalogue N°1

Main references used in heat tracing

Temperature adjustment ranges °C (°F)	Reference	Differential °C (°F)
4-40°C (40-105°F)	YF7GNC04040023ZJ	4±2°C(7.2±3.6°F)

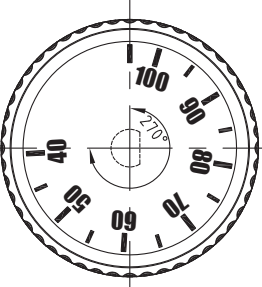
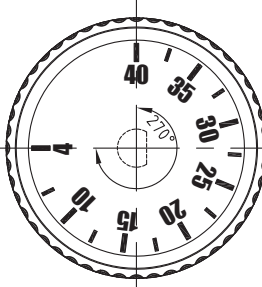
°F printing: replace last character (J) by K

Knob printings		Model with bulb and capillary for distant measurement (Technical data sheet available in catalogue number 2, second edition)
°F Printing	°C Printing	
40-105°F	4-40°C	YF9GNC
		

Update 2025/06/27

Contact us

www.ultimheat.com

Cat12-3-6-15



Because of permanent improvement of our products, drawings, descriptions, features used on these data sheets are for guidance only and can be modified without prior advice



Section 7

Electronic controllers, for ambient temperature measurement, with **built-in or remote temperature sensor.**



The advantages of electronic temperature control in heat tracing applications

- Increased accuracy.
- Different possible output actions (on certain models).
 - Adjustable differential.
- Greater distance between the probe and the control box.
- Possible separation between the probe and the control box facilitating the installation of the two separately.
 - Visible temperature display (on some models)

Digital display electronic controller, Din Rail mounting, ON-OFF, for heat tracing

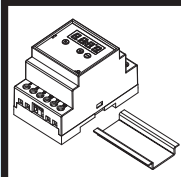
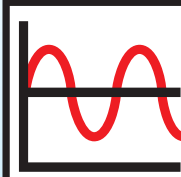
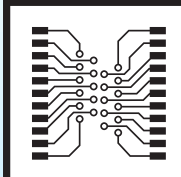
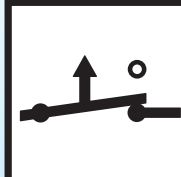
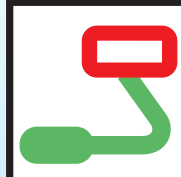

Because of permanent improvement of our products, drawings, descriptions, features used on these data sheets are for guidance only and can be modified without prior advice

Enclosure	Type	Operation	Contact	Measurement	Ranges °C	Type
Din Rail	Control	Electronic	SPNC	Distant sensor	Multi-parameters	2DNAP6
						

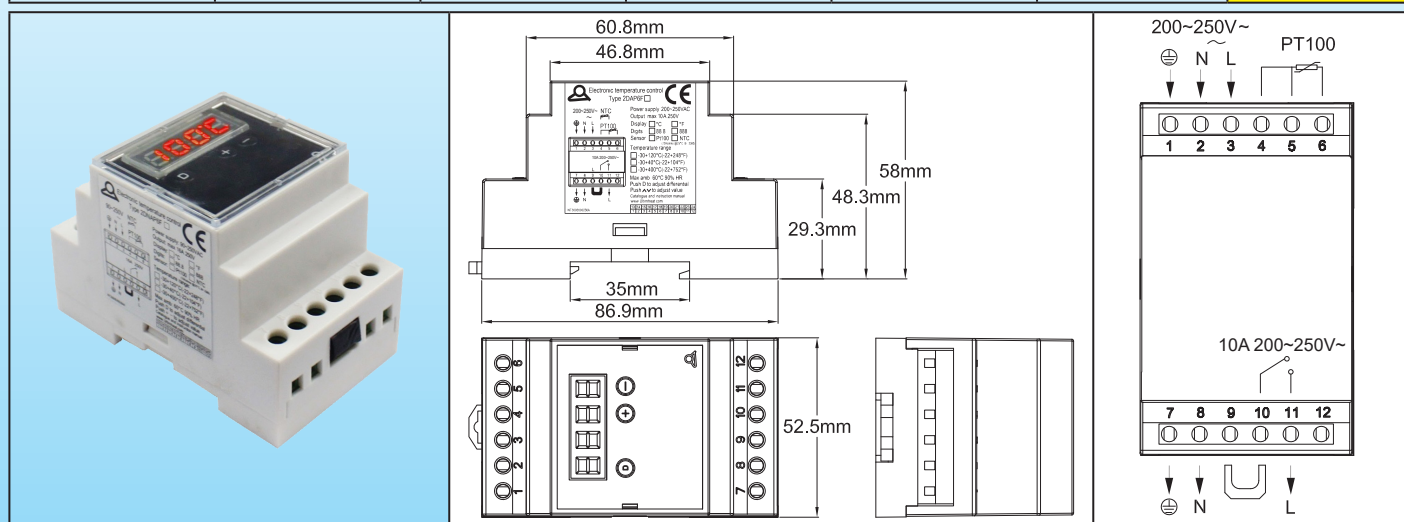

Applications

- Indoor mounting, in a box or a cabinet with Din rail, for control of frost protection and electrical tracing systems. (Defrosting and snow removal of gutters, roofs, heated parking ramps).

This electronic temperature controller with the **simplest and the most instinctive setting by end user** was designed for easy incorporation inside cabinets with DIN rail mounting. It can be used by untrained operators.

It provides simple On Off action temperature control.

It is possible to set °C or °F display, heating or cooling relay output, decimal display, sensor type and temperature range by internal Dip switches (Without access by end user).

End user has access to set point and differential setting only.

Adjustment of maximum temperature can be set without need to open the control.

Technical features

Dimensions: 86.9 × 58 × 52.5mm

Display: 3+1 digits, LED. The fourth digit is used to display °C or °F, upon setting made.

Set point setting: In normal use, the display shows the measured temperature. Push "+" or "-" keys will display the set point value, and at that time it can be adjusted with "+" and "-" keys. No action during 5 seconds will register the new set point value and bring back display to measured value.

Temperature differential setting: In normal use, the display shows the measured temperature. Push "D" key will display the differential value, at that time it can be adjusted with "+" and "-" keys. Push "D" again or no action during 5 seconds will register the new differential value and bring back display to the measured value.

Action: On-Off

Temperature sensor: Pt100 (2 or 3 wires) or NTC 10Kohms @25°C, B= 3380 (2 wires) Temperature sensor can be selected by a dip switch on circuit (No access to final user)

Accuracy: ±1% of scale

Temperature adjustment ranges:

-30+120°C (-20+250°F), with 1° display

-30,0 to +40,0°C (-20,0 + 99,9°F), with 1/10° display

-30+400°C (-20+750°F), with 1° display

Temperature range and decimal digit can be selected by a dip switch on circuit (No access to final user).

Power supply: 200 to 250V~, 50Hz or 60Hz.

Relay output: SPNO when there is no power supply, 10A 200~250V res., 100,000 cycles. Output Led displays relay position

Relay action: Heating or cooling, open or close on temperature rise output relay action can be selected by a dip switch on circuit (No access to final user)

Digital display electronic controller, Din Rail mounting, ON-OFF, for heat tracing



°C or °F display: can be selected by a dip switch on circuit (No access to final user).

Maximum possible set point adjustment by user: Push “D” button more than 10 seconds, display shows the maximum temperature that can be set by the user. Then it is possible to adjust this value with “+” and “-”. Push again on “D” or do nothing during 5 seconds will register the maximum possible setting value and control will come back to the measured value.

Ambient: -20+60°C, 10-90% RH

Power: <4W

Fail safe safety:

- If no power supply, relay output contact will open
- If Pt100 sensor or NTC is broken or not connected properly, relay output contact will open and display will show “EEE”
- If measured temperature is higher than allowed by the set range, display will show HHH
- If measured temperature is lower than -30.0°C or -20.0°F, display will show LLL

Electrical connections:

- Power input: Neutral, phase, ground, with 2.5mm² terminals
- Power output: Neutral, phase, ground, with 2.5mm² terminals for direct connection to the load.
- Temperature sensor: three 2.5mm² screw terminal

One removable jumper provides a potential free relay output for applications needing a separate circuit for relay, external timer or other.

Internal parameter settings: Process is given on request to approved distributors. This allows to store only one product and set parameters upon end user request.

Options: Waterproof wall mounting box

Standards: CE certificate by TUV, and ROHS and Reach components.

Main references used in heat tracing (Temperature sensor not included*)

References	Temperature range	Sensor	Display
2DNAP6FE	-30, 0 to + 40, 0°C	Pt100	88.8C (°C)
2DNAP6FA	-30 + 120°C	NTC	888C (°C)
2DNAP6FF	-20.0 + 99.9°F	Pt100	88.8F (°F)
2DNAP6FB	-20 + 250°F	NTC	888F (°F)

* For compatible temperature sensors, see TSR5 and TNR6 products pages in this catalogue.

Because of permanent improvement of our products, drawings, descriptions, features used on these data sheets are for guidance only and can be modified without prior advice



Electronic room thermostats for heat tracing, metal box

Because of permanent improvement of our products, drawings, descriptions, features used on these data sheets are for guidance only and can be modified without prior advice

Enclosure	Type	Operation	Contact	Measurement	Ranges °C	Types
IP65, IK10	Control	Electronic	SPNC	Ambient		Y1A2P & Y1B2P
Material						
Aluminum						

Y1B2P: External adjustment (With pilot light)

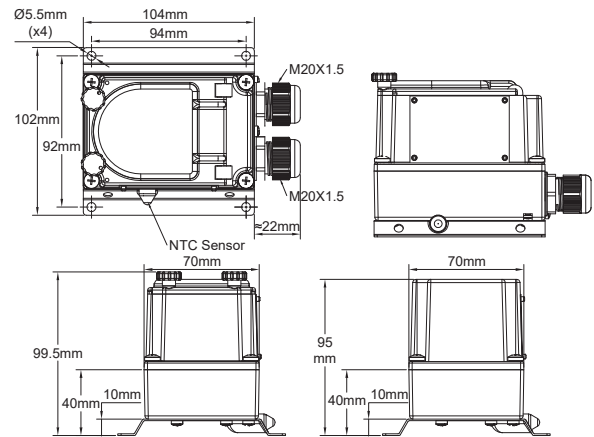

Y1A2P: Internal adjustment (Without pilot light)

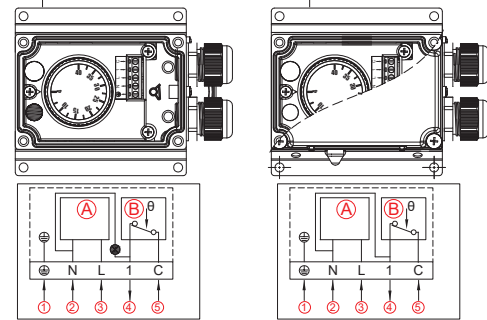
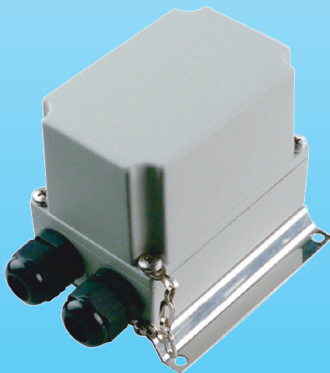

- (A) Electronic circuit
(B) Relay Max 16A 240V res.
- ① Ground
② Power supply 90-240V Neutral
③ Power supply 90-240V Line
- ④ Relay contact output
⑤ Relay contact Power supply

Example of assembly on two heat tracing cables of one Y1B2P, in combination with Y29 connection box



Example of assembly on two heat tracing cables, with Y26 connection box with stainless steel elevated bracket, for pipe antifreeze protection.

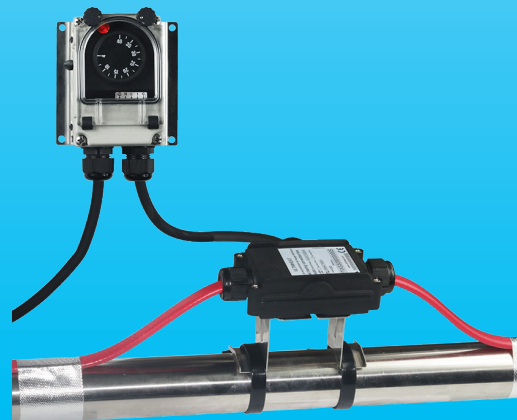



Applications

- Heavy duty industrial environments
- Outdoor antifreeze temperature control of heaters and heat tracing cables.
- Wall mounting for indoor or outdoor temperature control of cold rooms.
- Temperature control of industrial or commercial premises.
- Green houses and livestock stables temperature control.

Technical features

Housing: Aluminum, IP65, IK10. Mounted on a SUS304 stainless steel wall mounting plate which keeps the temperature sensing element away from the wall. Grey RAL7032 epoxy painting. Stainless steel captive cover screws. Captive aluminum lid.

Operation: Microprocessor electronic control thermostat.

Adjustment ranges: -35-35°C (-30+95°F), 0-10°C (32-50°F), 4-40°C (40-105°F).

Set point adjustment: By °C printed knob. All types have an adjustable rotation limit system located inside the knob that allows reducing the set point adjustment span. Types with external adjustment have a transparent window. This device allows seeing the pilot light and the knob position. °F values are available as an option.

Sensing element: NTC probe, mounted on the side of plastic housing.

Cable input and output: Two M20 cable glands, Black PA66. Internal electrical connection on screw terminals. 2 phase power supply (Line+ Neutral, 220~250V, 50Hz~60Hz) are mandatory.

Earthing: Internal and external screw terminal.

Pilot light: Allow to visualize thermostat contact output position. Standard for all models with transparent window. Non- standard and on special request only for models with plain aluminum cover.

Mounting: Wall mounting, by 4 holes for screws dia. 4 to 5mm, 94 × 92mm distance.

Identification: Metallic identification label, riveted.

Contact: SPST. 16A (2.6), 250VAC. Open on temperature rise.

Electrical life: >100.000 cycles.

Minimum storage temperature: -35°C (-30°F)

Maximum ambient temperature: 60°C (140°F)

Options: Models with remote temperature sensor

For more technical information on the electronic part, see 2PE2N6 thermostat technical data sheet in catalog N°1

Main references used in heat tracing

Temperature adjustment ranges °C (°F)	Differential °C (°F)	References with external adjustment	References with internal adjustment
-35-35°C (-30+95°F)	0.5~0.8°C (0.9~1.4°F)	Y1B2PN6F235035AJ	Y1A2PN6F235035AJ
4-40°C (40-105°F)	0.5~0.8°C (0.9~1.4°F)	Y1B2PN6F204040AJ	Y1A2PN6F204040AJ

°F printing: replace last character (J) by K.

Knob printings				Similar products (For more information these models, see the catalogue number 2, second edition)	
°F Printing		°C Printing		Y1G2P	Y1I2P
-30+95°F	40+105°F	-35+35°C	4-40°C	Electronic temperature control with distant sensor and internal adjustment	Electronic temperature control with distant sensor and adjustment under window



Electronic room thermostats for heat tracing

Enclosure	Type	Operation	Contact	Measurement	Ranges °C	Type
IP66, IK10	Control	Electronic	SPNC	Ambient		YF62NC
Material						
PA66 & PC						

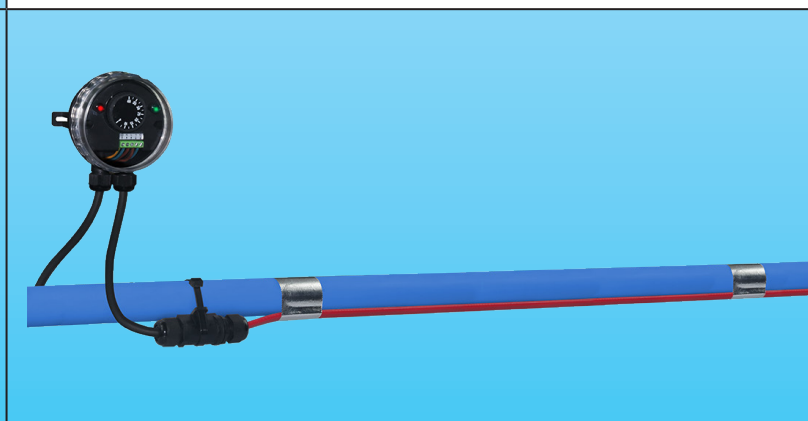
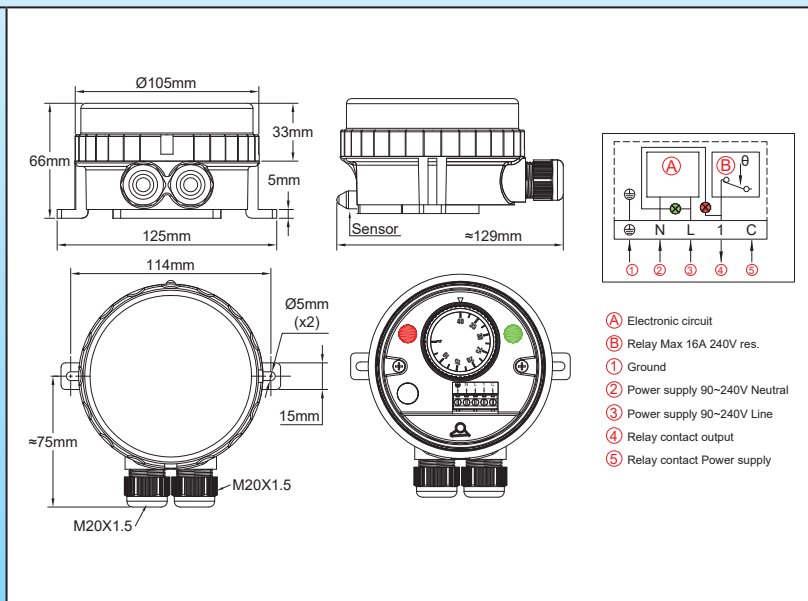

Example of assembly on two heat tracing cables, in combination with Y29 connection box

Example of assembly on one heat tracing cable, with Y24 connection box, for PVC pipe antifreeze protection

Applications

- Equipment requesting a very strong resistance to water ingress. The transparent cover allows to visualize the set point and the 2 pilot lights.
- Outdoor antifreeze temperature control of heaters and heat tracing cables.
- Wall mounting for indoor or outdoor temperature control of cold rooms.
- Temperature control of industrial or commercial premises.
- Green houses and livestock stables temperature control.
- **Very small differential**

Technical features

Housing: Protection class IP 66 upon EN 60529 (waterproof spray water under high pressure and sea splashes, totally dust tight). Body in black PA66, fiber glass reinforced. The transparent polycarbonate cover can be unscrewed by hand, but it is also possible to use a hook spanner. Mechanical impact resistance: IK10. High UV resistance.



Electronic room thermostats for heat tracing

Set point adjustment: By °C printed knob. All types have an adjustable rotation limit system located inside the knob that allows reducing the set point adjustment span. °F printed knobs available as an option.

Operation: Microprocessor electronic thermostat.

Sensing element: NTC probe, mounted on the top of the plastic housing.

Pilot lights: One pilot light visualizes the thermostat contact output position. The other visualizes the power supply input. Phase and line 230V power supply is mandatory for these pilot lights.

Set point adjustment ranges: -35-35°C (-30+95°F), 0-10°C (32-50°F), 4-40°C (40-105°F).

Differential: Differential is preset at the minimum value, but can be increased with a potentiometer located under the set point adjustment knob.

Cable input and output: Two M20 cable glands, built-in, black PA66.

Electrical connections: Inside, on screw terminal connection block. It is possible to connect 2 wires 1.5mm² on each terminal.

Earthing: Internal screw terminal.

Mounting: Wall mounting, by 2 legs with holes for screws dia. 4 to 5mm, 114mm distance.

Identification: Identification label on backside.

Contact: SPST. 16A (2.6), 250VAC. Open on temperature rise.

Electrical life: >100.000 cycles.

Minimum storage temperature: -35°C (-30°F).

Maximum ambient temperature: 60°C (140°F).

Options: Models with remote temperature sensor

For more technical information see 2PE2N6 thermostat technical data sheet in catalog N°1.

Main references used in heat tracing

References with open on temperature rise contact	Temperature adjustment ranges °C (°F)*	Minimum differential °C (°F)
YF62NC350350000J	-35+35°C (-30+95°F)	0.5~0.8°C (0.9~1.4°F)
YF62NC000100000J	0+10°C (32-50°F)	0.5~0.8°C (0.9~1.4°F)
YF62NC040400000J	+4+40°C (40-105°F)	0.5~0.8°C (0.9~1.4°F)

* °F printing: replace last character (J) by K.

Knob printings

°C Printing			°F Printing		
-35+35°C	0-10°C	4-40°C	-30+95°F	32-50°F	40+105°F

Model with remote sensor

(Technical data sheet available in catalogue number 2, second edition)



**Electronic thermostat, NTC sensor,
for heat trace pipe temperature control, remote wall mounting**



Because of permanent improvement of our products, drawings, descriptions, features used on these data sheets are for guidance only and can be modified without prior advice

Temperature ranges	Mounting	Adjustment	Sensor	Action type	Types
-35+35°C (-30+95°F) 0-10°C (32-50°F) 4-40°C (40-105°F) 30-90°C (85-190°F) 30-110°C (85-230°F) 20-125°C (68-260°F)	Wall mounting	Printed knob	NTC thermistor	On-Off	Y8WR-X Y8WR-Y

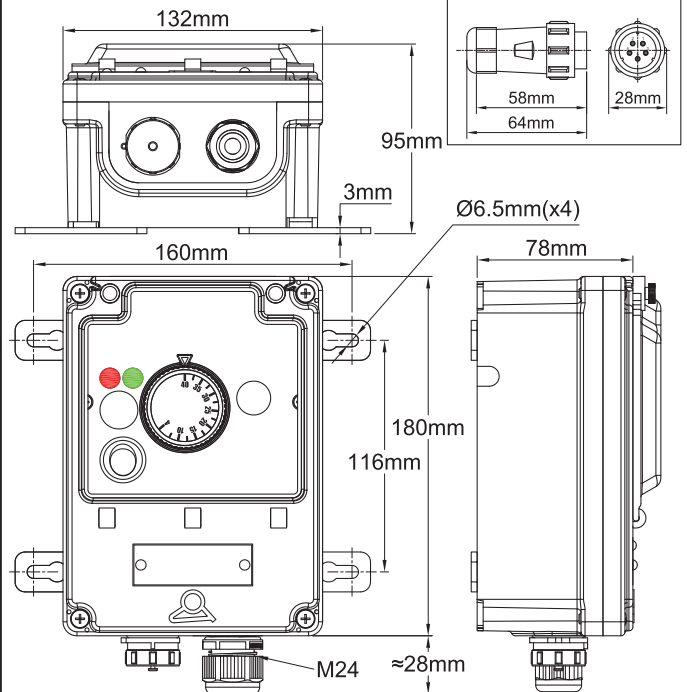
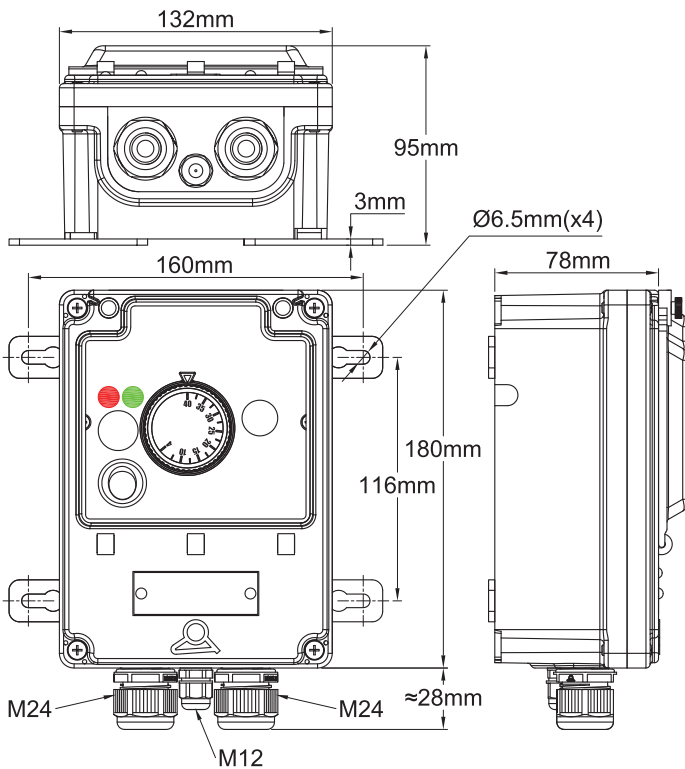

Model with 3 cable glands (2 × M24 + 1 × M12): Y8WR-X

Model with one 5 ways connector and one M24 cable gland: Y8WR-Y

Electronic thermostat, NTC sensor, for heat trace pipe temperature control, remote wall mounting

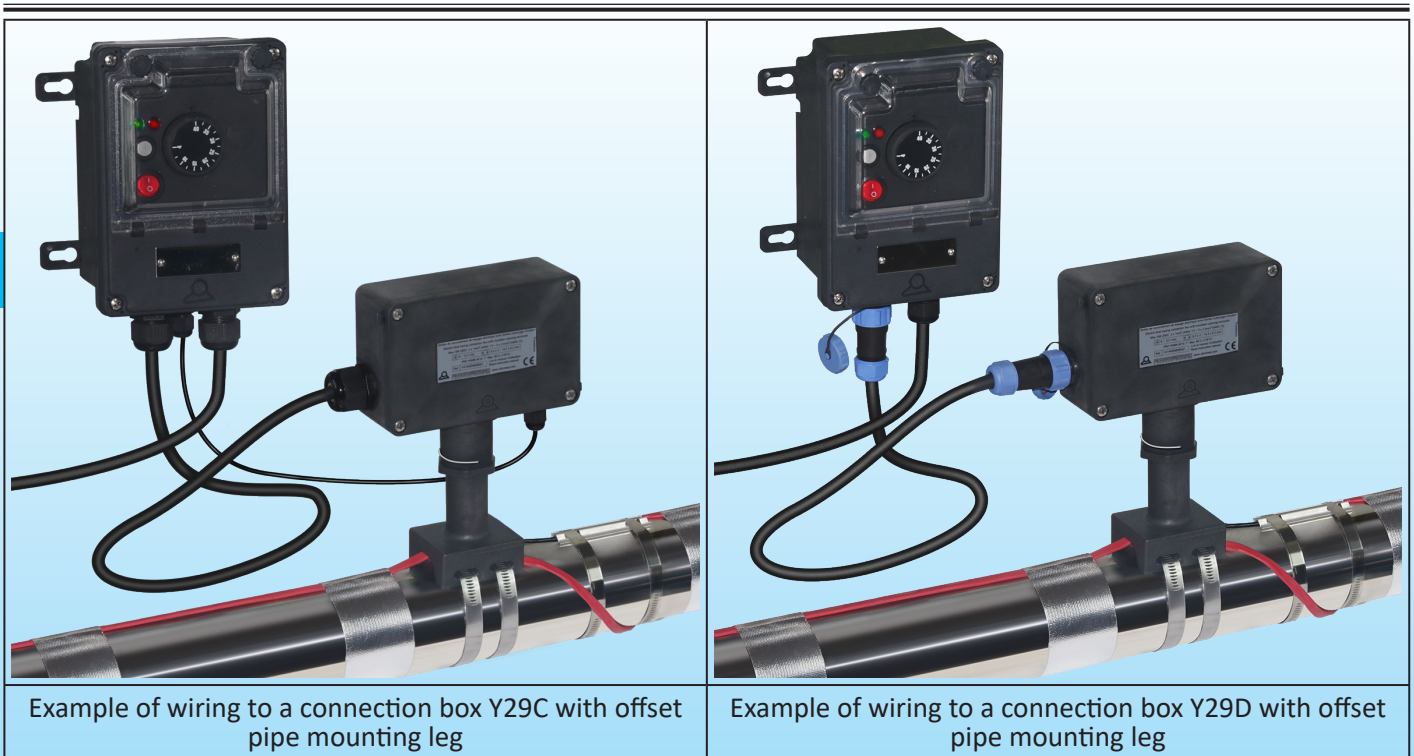

Example of wiring to a connection box Y29C with offset pipe mounting leg

Example of wiring to a connection box Y29D with offset pipe mounting leg

Applications

These waterproof control boxes with wall mounting allow **remote** control of the surface temperature of the pipes. **The connection to the heating elements is via a connection box** with or without **offset mounting foot**, type Y26, Y27, Y28, Y29, or with a 3-conductor power cable and a separate NTC temperature sensor cable, or by an offset mounting foot connection box type Y29B and a **single 5-conductor cable** equipped with a 5-way connector. The use of this model is simple and intuitive, **similar to electromechanical thermostats**, and does not need specially trained users. **The use of a wired temperature measurement sensor, which can be disconnected, allows to overcome the problems of wall crossing of bulb thermostats, the capillary of which cannot be cut, and to proceed with installation of connection and control boxes after mounting the heating cables and the temperature sensor, installation of the pipe insulation and installation of the insulation protection sheath.**

Main features

Enclosure: IP69K, reinforced PA66, with polycarbonate window access. Sealable cover and window.

Wall mounting: Four removable and rotatable legs.

Electrical connection:

- On internal terminal block for power supply on all models.
- On the model with 3 cable glands: On internal terminal block for the output and the temperature sensor.
- On the model with output by 5-way connector, the internal wiring of the power output and the temperature sensor to the connector is carried out.

Cable glands:

- Three cable glands model: Two M24 cable glands for power supply and power output and one M12 cable gland for the temperature sensor.
- 5-way connector model: A 5-way female connector mounted on the wall of the housing and a 5-way male connector to be mounted on cable, and an M24 cable gland for the power supply cable.

Miscellaneous devices: Main illuminated switch and safety fuse.

Electronic thermostat: Adjustment by knob printed in °C or in °F.

Action: ON-Off. (The differential adjustment is possible by a potentiometer accessible by removing the knob)

Temperature sensor: NTC, R @ 25°C: 10 Kohms (± 1%), B @ 25/50° 3380 Kohms (± 1%). Interchangeable sensors.

Power output: By 16A 230V resistive relay

Power supply: 220-230V AC, 50-60Hz.

Self-check: Open sensor circuit detection.

Ambient temperature: -10 to 60°C, 20 to 85% relative humidity, non-condensing.

Option: Pipe mounting bracket. Screwed on the back of the case, it allows mounting on a horizontal or vertical tube, at a distance of about 50mm. (See accessories 6YTPT).

Because of permanent improvement of our products, drawings, descriptions, features used on these data sheets are for guidance only and can be modified without prior advice

**Electronic thermostat, NTC sensor,
for heat trace pipe temperature control, remote wall mounting**



Main part numbers, temperature sensor not included (With °C printed knob*)

Temperature ranges	Model with 3 cable glands (2 × M24 +1 × M12)	Model with one 5 ways connector and one M24 cable gland
-35+35°C (-30+95°F)	Y8WRC02100000AUX	Y8WRC02100000AUY
0-10°C (32-50°F)	Y8WRR02100000AUX	Y8WRR02100000AUY
4-40°C (40-105°F)	Y8WRD02100000AUX	Y8WRD02100000AUY
30-90°C (85-190°F)	Y8WRE02100000AUX	Y8WRE02100000AUY
30-110°C (85-230°F)	Y8WRF02100000AUX	Y8WRF02100000AUY
20-125°C (68-260°F)	Y8WRM02100000AUX	Y8WRM02100000AUY

* For °F printed knobs, replace 100 by 102 in the reference.

** For models with backside mounted stainless steel bracket for pipe mounting, replace 021 by V21 in the reference.



Example of assembly with option of backside mounting bracket 6YTPT on horizontal pipe

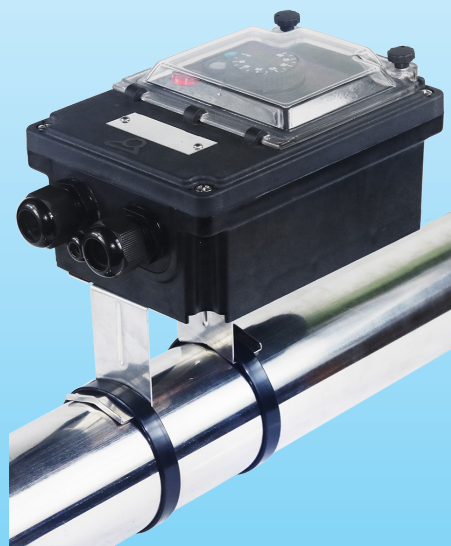

Example of assembly with option of backside mounting bracket 6YTPT on vertical pipe

Wiring

<p align="center">Power connection on 3 cables glands model</p>	<p align="center">Temperature sensor connection on 3 cables glands model</p>	<p align="center">Power and temperature sensor connections on connector model</p>

Because of permanent improvement of our products, drawings, descriptions, features used on these data sheets are for guidance only and can be modified without prior advice

Electronic temperature controller with **digital display**, **NTC sensor**,
for heat trace **pipe temperature control**, **remote wall mounting**



Temperature ranges	Mounting	Adjustment	Sensor	Action type	Types
-45+120°C (-49+250°F)	Wall mounting	Digital	NTC thermistor	On-Off	Y8WH-X Y8WH-Y

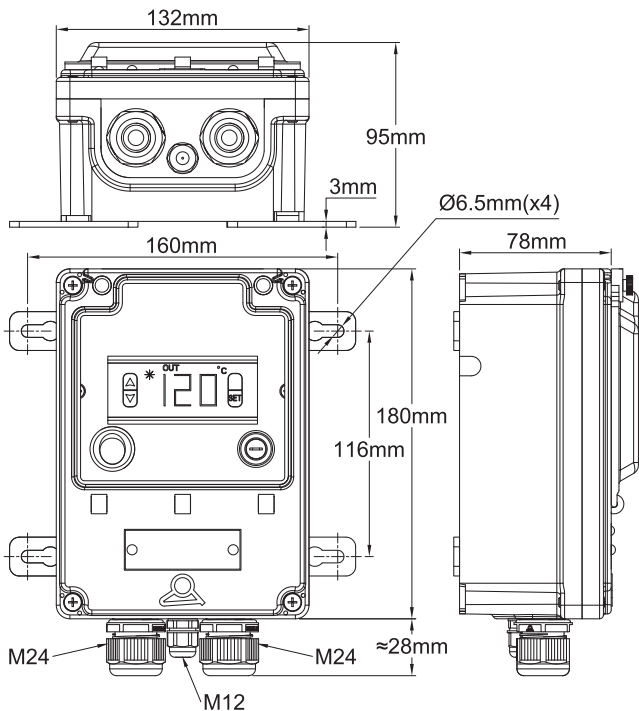

Model with 3 cable glands (2 × M24 + 1 × M12): Y8WH-X

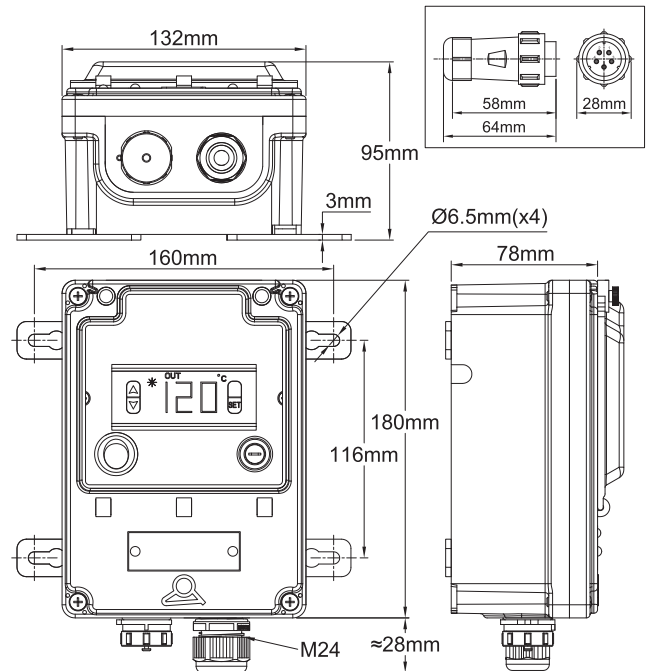

Model with one 5 ways connector and one M24 cable gland: Y8WH-Y

Because of permanent improvement of our products, drawings, descriptions, features used on these data sheets are for guidance only and can be modified without prior advice

Electronic temperature controller with **digital display**, **NTC sensor**,
for heat trace **pipe temperature control**, **remote wall mounting**



Because of permanent improvement of our products, drawings, descriptions, features used on these data sheets are for guidance only and can be modified without prior advice

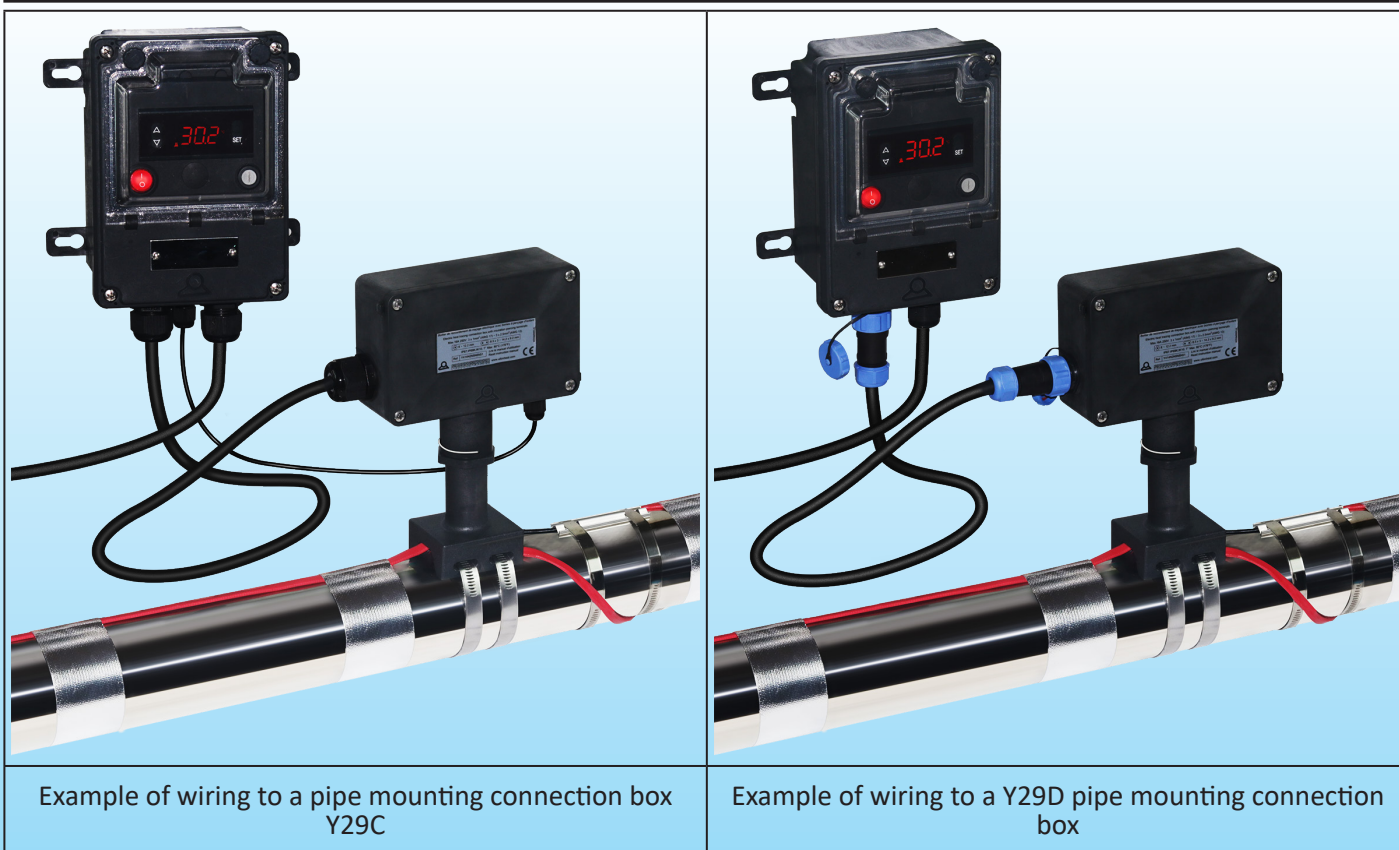

Example of wiring to a pipe mounting connection box Y29C

Example of wiring to a Y29D pipe mounting connection box

Applications

These waterproof control boxes with wall mounting allow **remote** control of the surface temperature of the pipes. **The connection to the heating elements is via a connection box** with or without offset mounting foot type Y26, Y27, Y28, Y29, or with a 3-conductor power cable and a separate NTC temperature sensor cable, or by an offset mounting foot connection box type Y29B and a **single 5-conductor cable** equipped with a 5-way connector. The use this model with **digital display** is simple and intuitive, and does not need specially trained users.

The use of a wired temperature measurement sensor, which can be disconnected, allows to overcome the problems of wall crossing of bulb thermostats, the capillary of which cannot be cut, and to proceed with installation of connection and control boxes after mounting the heating cables and the temperature sensor, installation of the pipe insulation and installation of the insulation protection sheath.

Main features

Enclosure: IP69K, reinforced PA66, with polycarbonate window access. Sealable cover and window.

Wall mounting: Four removable and rotatable legs.

Electrical connection:

- On internal terminal block for power supply on all models.
- On the model with 3 cable glands: On internal terminal block for the output and the temperature sensor.
- On the model with output by 5-way connector, the internal wiring of the power output and the temperature sensor to the connector is carried out.

Cable glands:

- Three cable glands model: Two M24 cable glands for power supply and power output and one M12 cable gland for the temperature sensor.
- 5-way connector model: A 5-way female connector mounted on the wall of the housing and a 5-way male connector to be mounted on cable, and an M24 cable gland for the power supply cable.

Switching devices: Main illuminated switch and safety fuse

Controller: With very simple end-user interface. Change of set point is made without password, with up and down keys.

Action: On-Off with adjustable differential.

Display: Can be selected in °C or °F

Sensor input: NTC, R@25°C: 10 Kohms (±1%), B@25/50°C: 3380 (±1%).

Power output: 16A 230V res. relay.

Display: 3 digits

Power supply: AC 220-230V 50-60Hz.

Accuracy: ±1°C (±2°F) or 0.3% end of scale ± one digit.

Self-testing: Over-scale, under-scale, and open sensor circuit.

Electronic temperature controller with digital display, NTC sensor, for heat trace pipe temperature control, remote wall mounting



Ambient temperature: -10 to 60°C, 20 to 85% relative humidity, non-condensing.

Options:

- Pt100 or K thermocouple sensor.
- Pipe mounting bracket. Screwed on the back of the case, it allows mounting on a horizontal or vertical tube, at a distance of about 50mm. (See accessories 6YTQT).

Main part numbers*, temperature sensor not included

Part numbers	Output to heating elements and temperature sensors
Y8WHQ02100000AUX	Model with 3 cable glands (2 × M24 +1 × M12)
Y8WHQ02100000AUY	Model with one 5 ways connector and one M24 cable gland

* For models with backside mounted stainless steel bracket for pipe mounting, replace 021 by V21 in the reference.

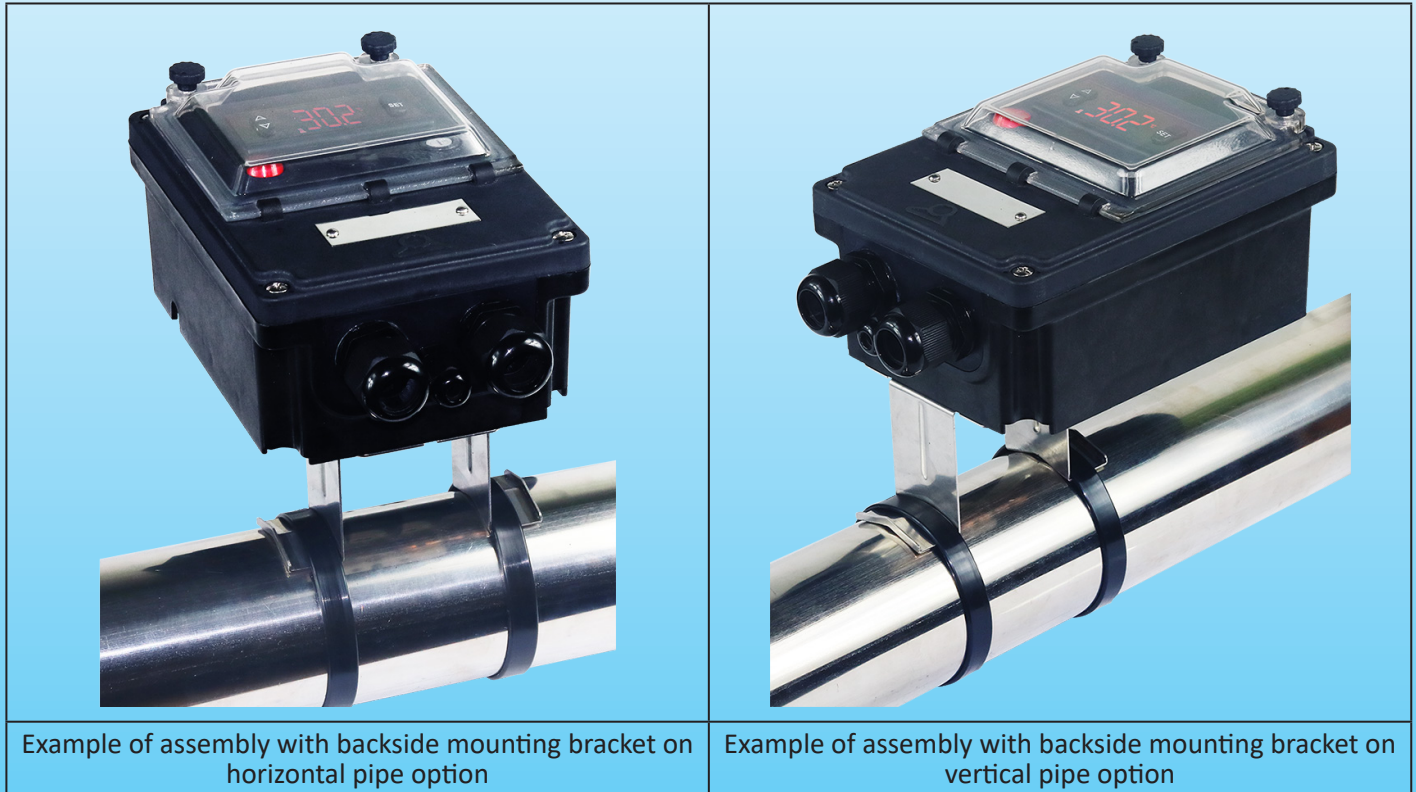

Example of assembly with backside mounting bracket on horizontal pipe option

Example of assembly with backside mounting bracket on vertical pipe option

Wiring

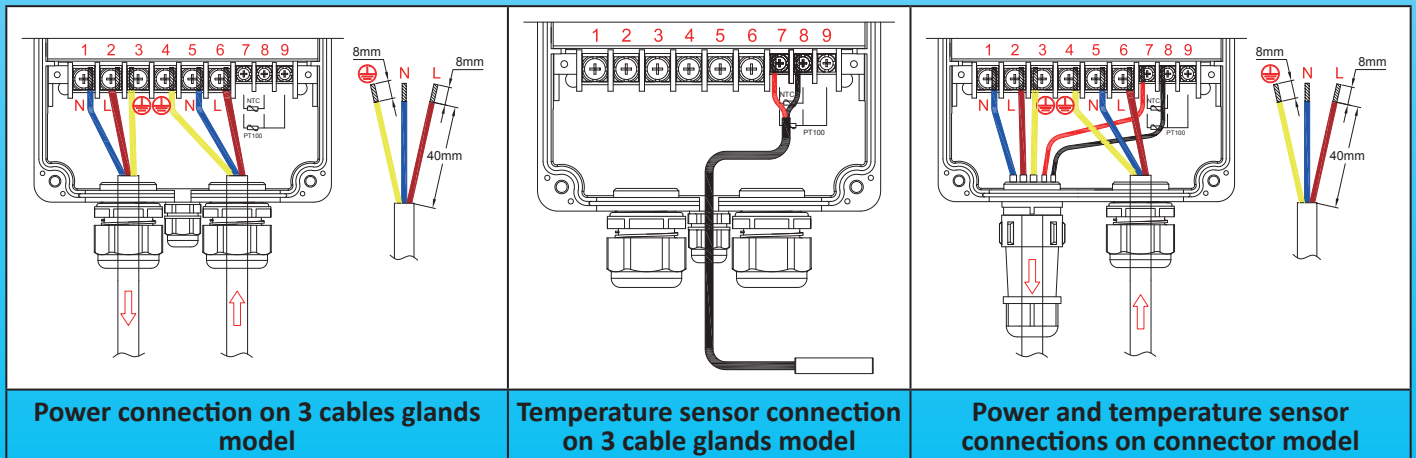

Power connection on 3 cables glands model

Temperature sensor connection on 3 cable glands model

Power and temperature sensor connections on connector model

Electronic temperature controller with **double digital display, multi-sensors, PID or ON-OFF action, for heat trace pipe temperature control, remote wall mounting**



Because of permanent improvement of our products, drawings, descriptions, features used on these data sheets are for guidance only and can be modified without prior advice

Temperature ranges	Mounting	Adjustment	Sensor	Action type	Types
Multi-parameters	Wall mounting	Digital double display	Multi-parameters	Multi-parameters	Y8WJ-X Y8WJ-Y

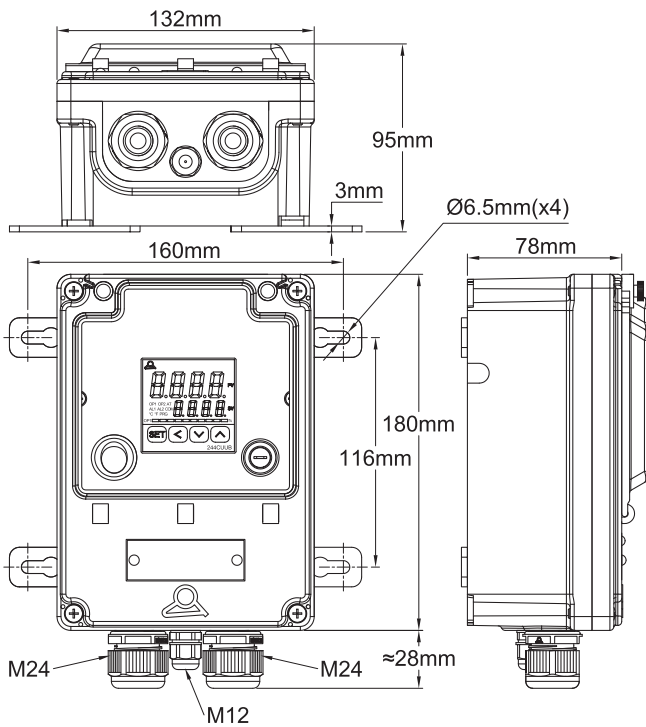

Model with 3 cable glands (2 × M24 +1 × M12): Y8WJ-X

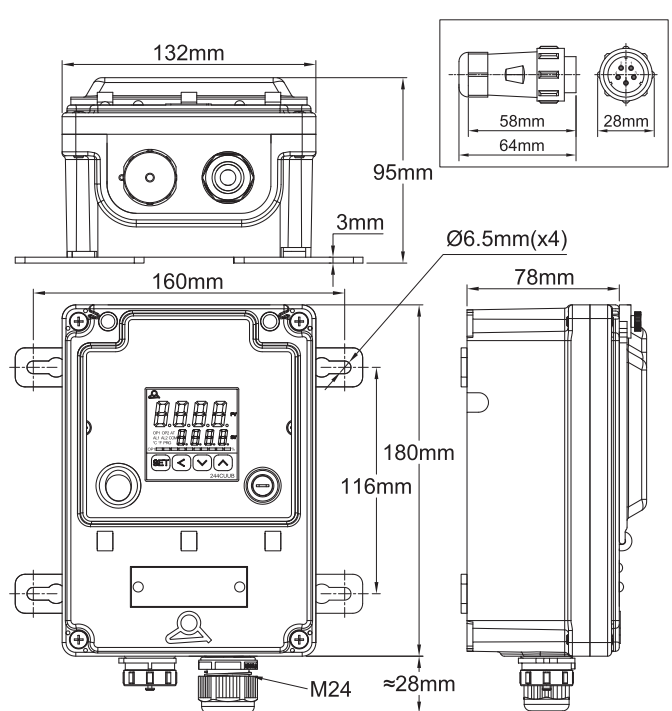

Model with one 5 ways connector and one M24 cable gland: Y8WJ-Y



Example of wiring to a pipe mounting connection box Y29C

Example of wiring to a Y29D pipe mounting connection box

Applications

These waterproof control boxes with wall mounting allow **remote** control of the surface temperature of the pipes. **The connection to the heating elements is via a connection box** with or without offset mounting foot type Y26, Y27, Y28, Y29, or with a 3-conductor power cable and a separate NTC temperature sensor cable, or by an offset mounting foot connection box type Y29B and a **single 5-conductor cable** equipped with a 5-way connector.

The electronic controller used is designed to be **the most universal**. It is totally configurable. Its use requires reading and understanding of its instructions of use.

It includes an auto-tune function allowing automatic adjustment of PID parameters. The incorporation of a microprocessor using Fuzzy Logic technology makes it possible to reach a predetermined setpoint as quickly as possible, with a minimum of overheat during disturbances related to the ramp-up or the external load. A 20A 250V solid state relay board is included in standard.

The temperature sensor input is configurable, and in particular allows the **use of Pt100 RTD**

The use of a wired temperature measurement sensor, which can be disconnected, allows to overcome the problems of wall crossing of bulb thermostats, the capillary of which cannot be cut, and to proceed with installation of connection and control boxes after mounting the heating cables and the temperature sensor, installation of the pipe insulation and installation of the insulation protection sheath.

Main features

Enclosure: IP69K, reinforced PA66, with polycarbonate window access. Sealable cover and window.

Wall mounting: Four removable and rotatable legs.

Electrical connection:

- On internal terminal block for power supply on all models.
- On the model with 3 cable glands: On internal terminal block for the output and the temperature sensor.
- On the model with output by 5-way connector, the internal wiring of the power output and the temperature sensor to the connector is carried out.

Cable glands:

- Three cable glands model: Two M24 cable glands for power supply and power output and one M12 cable gland for the temperature sensor.
- 5-way connector model: A 5-way female connector mounted on the wall of the housing and a 5-way male connector to be mounted on cable, and an M24 cable gland for the power supply cable.

Switching devices: Main illuminated switch and safety fuse.

Controller: Double display, of process value and of set-point.

Action: PID with automatic parameters adjustment by auto-tune function. It can also be set in ON-OFF action with adjustable differential

Sensor input: Configurable for Pt100, K thermocouple and other sensors

Electronic temperature controller with double digital display, multi-sensors, PID or ON-OFF action, for heat trace pipe temperature control, remote wall mounting



Because of permanent improvement of our products, drawings, descriptions, features used on these data sheets are for guidance only and can be modified without prior advice

Power output: 20A 230V solid state relay.

Alarm: 3A 230V relay.

Display: 4 digits display configurable in °C or °F

Power supply: AC 220-230V 50-60Hz.

Accuracy: ±1°C (±2°F) or 0.3% end of scale ± one digit.

Self-testing: Over-scale, under-scale, and open sensor circuit.

Ambient temperature: -10 to 60°C, 20 to 85% relative humidity, non-condensing.

Option: Pipe mounting bracket. Screwed on the back of the case, it allows mounting on a horizontal or vertical tube, at a distance of about 50mm. (See accessories 6YTPT).

Main part numbers*, temperature sensor not included

Part numbers	Output to heating elements and temperature sensors
Y8WJU021D0000AUX	Model with 3 cable glands (2 × M24 +1 × M12)
Y8WJU021D0000AUY	Model with one 5 ways connector and one M24 cable gland

* For models with backside mounted stainless steel bracket for pipe mounting, replace 021 by V21 in the reference

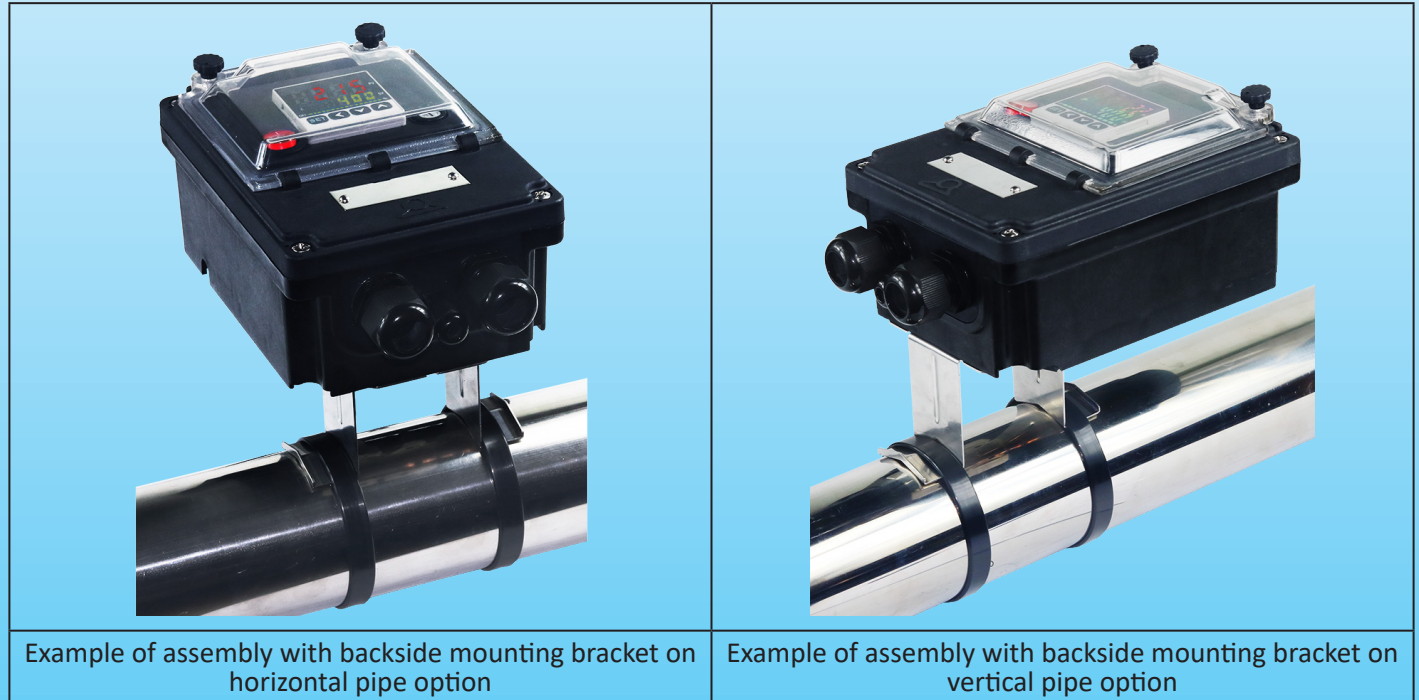

Example of assembly with backside mounting bracket on horizontal pipe option

Example of assembly with backside mounting bracket on vertical pipe option

Wiring

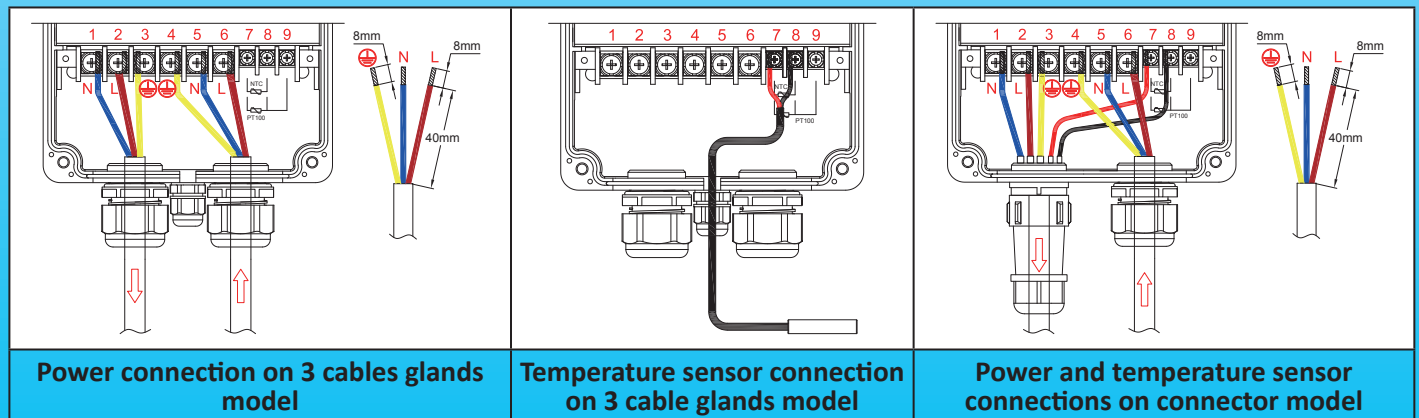

Power connection on 3 cables glands model

Temperature sensor connection on 3 cable glands model

Power and temperature sensor connections on connector model

Electronic thermostat, **NTC sensor**, for heat trace **pipe temperature control, vertical foot mounting on pipe**



Because of permanent improvement of our products, drawings, descriptions, features used on these data sheets are for guidance only and can be modified without prior advice

Temperature ranges	Mounting	Adjustment	Sensor	Action type	Types
-35+35°C (-30+95°F) 0-10°C (32-50°F) 4-40°C (40-105°F) 30-90°C (85-190°F) 30-110°C (85-230°F) 20-125°C (68-260°F)	Vertical foot mounting on pipe	Printed knob	NTC thermistor	On-Off	Y8WR-Z

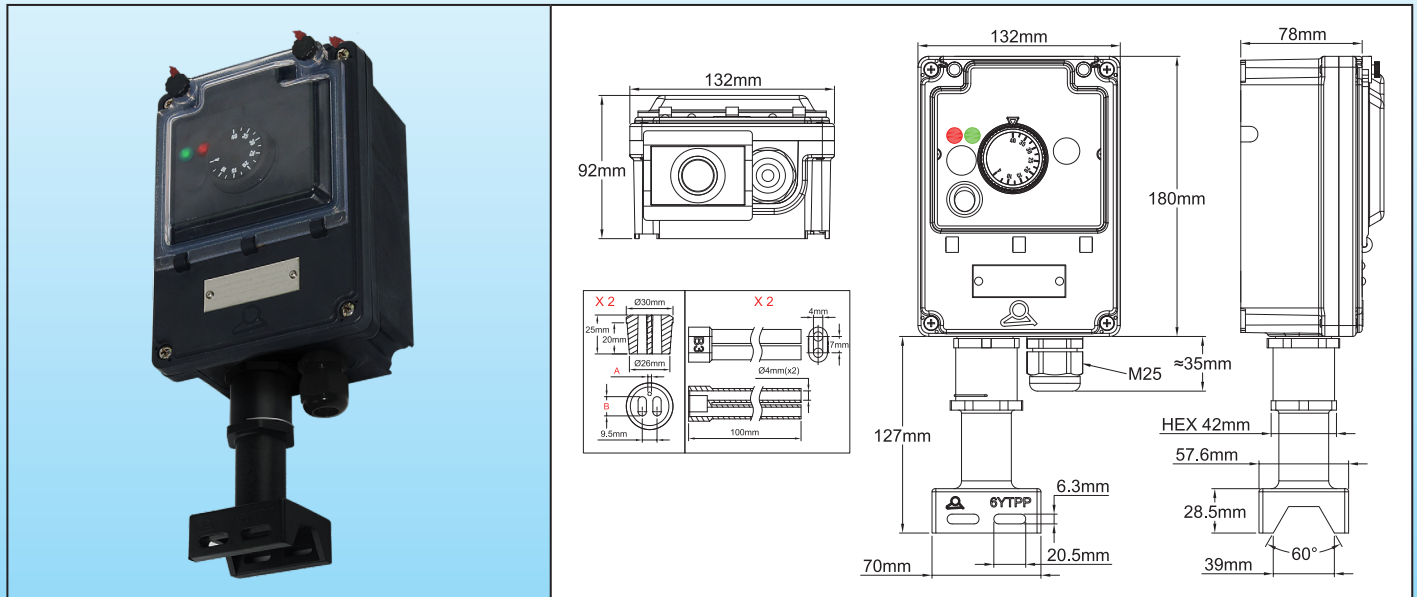

Example of assembly on pipe

Applications

These waterproof control boxes designed for **vertical mounting on pipes** allow to control the surface temperature of pipes **on site**. The connection to the heating elements and the temperature sensor is made by a pipe mounting foot incorporating the seal.

The use of this model is simple and intuitive, similar to electromechanical thermostats, and **does not need specially trained users**.

The use of a wired temperature measurement sensor, which can be disconnected, overcomes the wall crossing problems of bulb thermostats, the capillary of which cannot be cut. Then proceeding to installation of the temperature control unit after mounting the heating cables and the temperature sensor is possible, as well as after installation of the pipe insulation and its protective sheath if they exist.



Main features

- Enclosure:** IP69K, reinforced PA66, with polycarbonate window access. Sealable cover and window.
- Assembly:** Pipe mounting by PPS foot with heating cables crossing watertight seal. Two passages are provided in the foot for tightening it on the pipe by two nylon ties or metal hose clamps.
- Cable gland and foot:** Mounted on a removable board, facilitating assembly. This board has an M25 cable gland for the power supply cable. The heating cables exit through the foot. (The PPS foot is shipped unassembled on the box)
- Foot gasket:** Is mounted inside the foot as standard, a silicone seal designed for two heating cables and one hole for temperature sensor cable dia. 2 to 3mm. (For more information about these seals, see the catalogue page on 6YTPP pipe mounting legs)
- Accessories:** Are included two flexible boots in silicone with two bus wire funnels, length 100mm, intended to shield the conductors of the self-regulating cables after cutting off the heating zone. (For more information about these boots, see the accessories pages 6YTNB in this catalogue).
- Electrical connection:** On internal terminal block with screw terminals
- Cable gland:** One M25 cable gland for the power supply cable.
- Miscellaneous devices:** Main illuminated switch and safety fuse.
- Electronic thermostat:** Adjustment by knob printed in °C or in °F.
- Action:** ON-Off. (The differential adjustment is possible by a potentiometer accessible by removing the knob)
- Temperature sensor:** NTC, R @ 25°C: 10 Kohms (± 1%), B @ 25/50° 3380 Kohms (± 1%). Interchangeable sensors.
- Power output:** By 16A 230V resistive relay
- Power supply:** 220-230V AC, 50-60Hz.
- Self-check:** Open sensor circuit detection.
- Ambient temperature:** -10 to 60°C, 20 to 85% relative humidity, non-condensing.
- Option:** pipe seals with different cables section holes (See the range of 6YTRP seals in the various accessories pages)

Main part numbers, **temperature sensor not included*** (With °C printed knob**)

Temperature ranges	Part numbers***		
	Two holes for heating cables from 11x4mm to 13x6mm and one hole for temperature sensor cable diameter 2 to 3mm (Seal reference 6YTP11)	Two holes for heating cables from 9.5x2.5mm to 11x3.5mm and one hole for temperature sensor cable diameter 2 to 3mm (Seal reference 6YTP1).	Two holes for heating cables from 8x5mm to 9.5x6mm and one hole for temperature sensor cable diameter 2 to 3mm (Seal reference 6YTP21).
-35+35°C (-30+95°F)	Y8WRC02100200AUZ	Y8WRC02100100AUZ	Y8WRC02100300AUZ
0-10°C (32-50°F)	Y8WRR02100200AUZ	Y8WRR02100100AUZ	Y8WRR02100300AUZ
4-40°C (40-105°F)	Y8WRD02100200AUZ	Y8WRD02100100AUZ	Y8WRD02100300AUZ
30-90°C (85-190°F)	Y8WRE02100200AUZ	Y8WRE02100100AUZ	Y8WRE02100300AUZ
30-110°C (85-230°F)	Y8WRF02100200AUZ	Y8WRF02100100AUZ	Y8WRF02100300AUZ
20-125°C (68-260°F)	Y8WRM02100200AUZ	Y8WRM02100100AUZ	Y8WRM02100300AUZ

* For compatible temperature sensors, see the page on TNR6 products in this catalogue
 ** For °F printed knobs, replace 100 by 102 in the reference
 *** This seal is shipped with a plug allowing to use only one heating cable.

Because of permanent improvement of our products, drawings, descriptions, features used on these data sheets are for guidance only and can be modified without prior advice



Wrench for leg assembly (To be ordered separately)

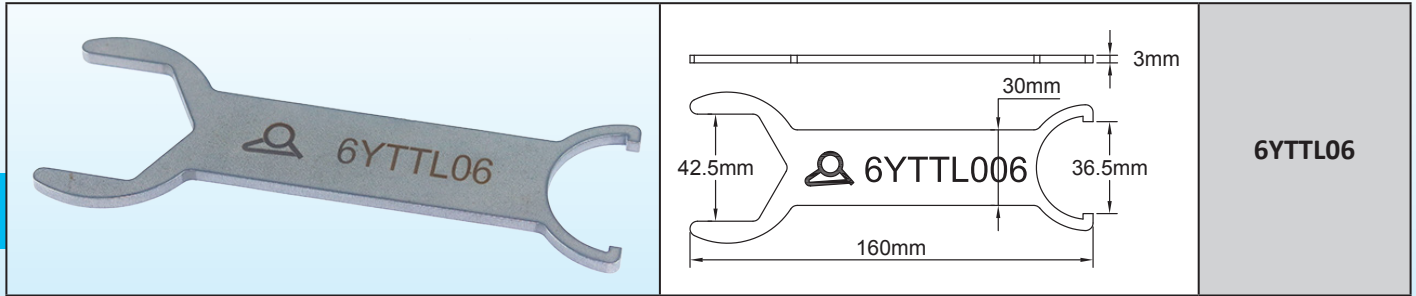

Stripping dimensions of the braided self-regulating cables, and of the power supply cable and their wiring.

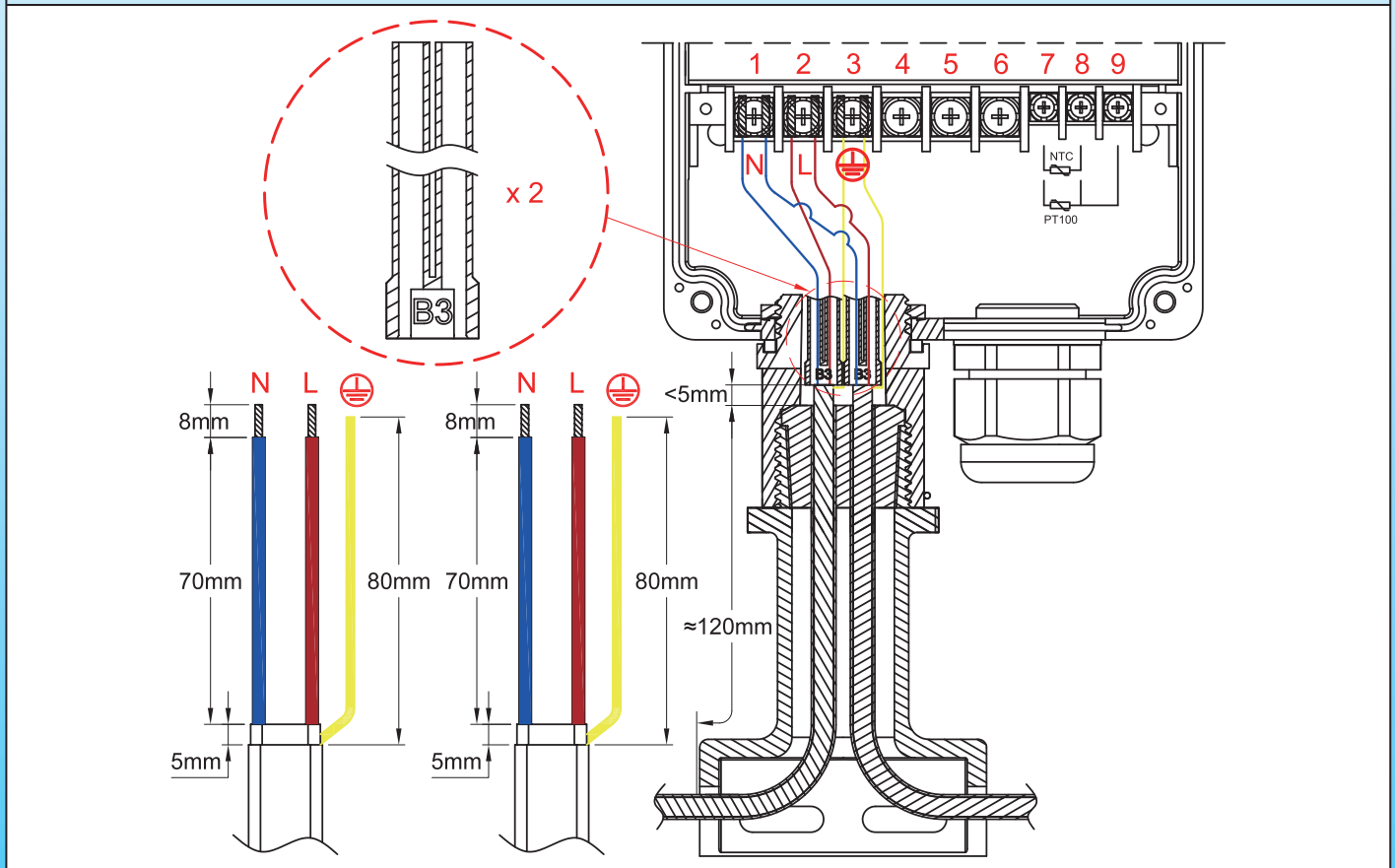

Self-regulating cables assembly steps

<p>1</p> <p>* 6YTTL04</p> <p>1: Cut the cable, remove the external jacket on the requested length</p>	<p>2</p> <p>2: Unweave the braid on all this length with a tool with round edges or a screw driver. (For more details about this step #2, read the technical introduction)</p>
--	---

* These exclusive tools are available in accessories section

Electronic thermostat, NTC sensor, for heat trace pipe temperature control, vertical foot mounting on pipe



Because of permanent improvement of our products, drawings, descriptions, features used on these data sheets are for guidance only and can be modified without prior advice

<p>3</p>	<p>4</p> <p>* 6YTTL04</p>
<p>3: Twist the braid to make a round wire.</p>	<p>4: Remove the electric insulation sleeving on the requested length.</p>
<p>5</p> <p>* 6YTTL05</p>	<p>6</p> <p>* 6YTTL04</p>
<p>5: Cut and remove the heating section between the two bus wires on the requested length</p>	<p>6: Strip off the semiconductor plastic remaining on the bus wire ends to the requested length.</p>
<p>7</p>	<p>8</p>
<p>7: Cut the stripped bus wires and the ground wire to the requested length.</p>	<p>8: Place the foot on the heating cables and on the temperature sensor cable, bringing them out from above, then slide the gasket over the cables. The outer insulating sheath must protrude from the gasket.</p>
<p>9</p>	<p>10</p>
<p>9: Fill the mouth of the silicone boot with silicone resin (RTV).</p>	<p>10: Slide the boot over the conductors of the heating cables, leaving the earth conductor outside.</p>

* These exclusive tools are available in accessories section

Electronic thermostat, NTC sensor, for heat trace pipe temperature control, vertical foot mounting on pipe



Because of permanent improvement of our products, drawings, descriptions, features used on these data sheets are for guidance only and can be modified without prior advice

<p>11</p>	<p>12</p>
<p>11: Compress the seal by screwing the upper part of the foot. When tightening is complete, a small spring comes to block the assembly (To disassemble, it is necessary to remove this small semi-circular spring).</p>	<p>12: Place the gasket in the upper recess of the foot, then the control unit above. Orient the housing according to the desired position, then place and tighten the toothed nut until it locks.</p>
<p>13</p>	

13: Connect the conductors and the temperature sensor according to the wiring diagram. Connect the power supply cable. Close the control box.

Stripping dimensions and wiring of the power supply cable

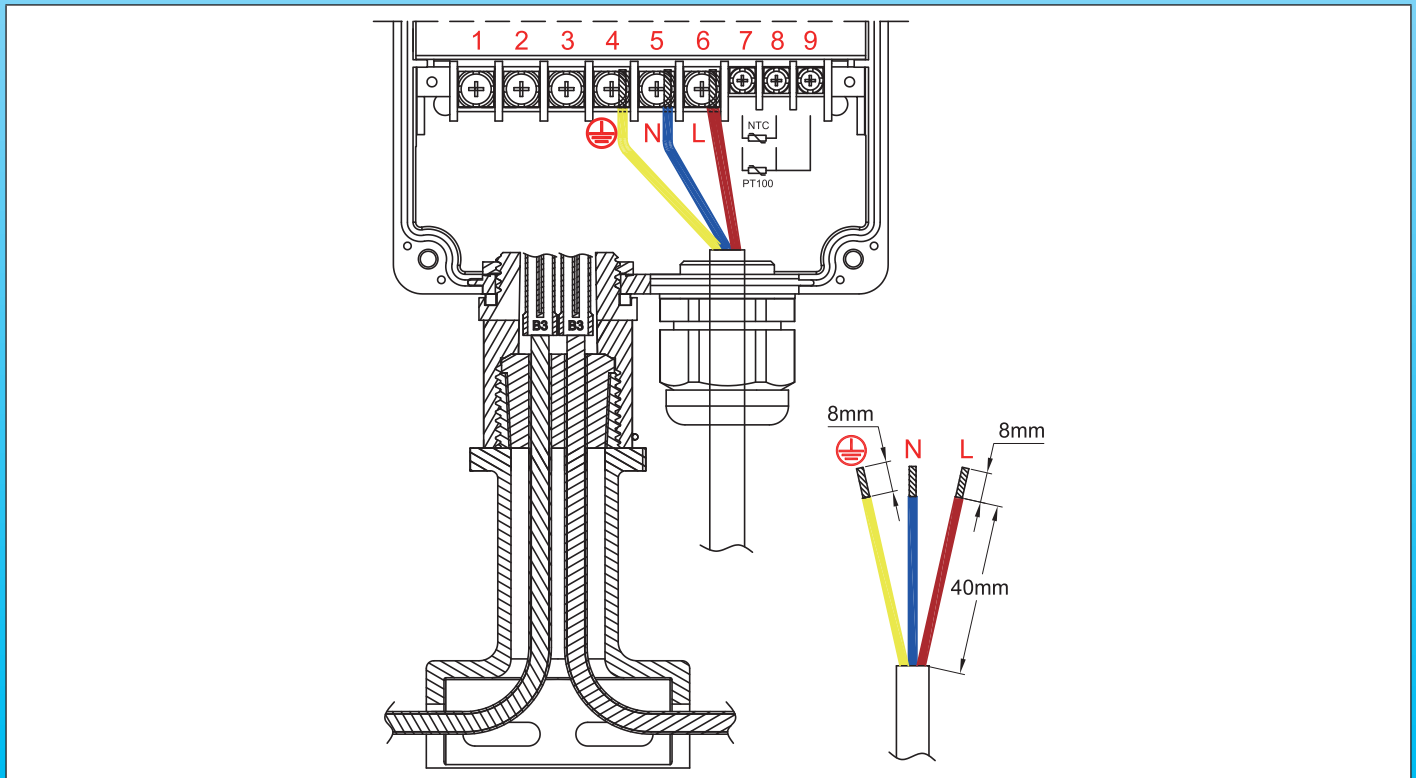

Electronic temperature controller with **digital display**, **NTC sensor**, for heat trace **pipe temperature control**, **vertical foot mounting on pipe**



Because of permanent improvement of our products, drawings, descriptions, features used on these data sheets are for guidance only and can be modified without prior advice

Temperature ranges	Mounting	Adjustment	Sensor	Action type	Type
-45+120°C (-49+250°F)	Vertical foot on pipe	Digital	NTC thermistor	On-Off	Y8WH-Z

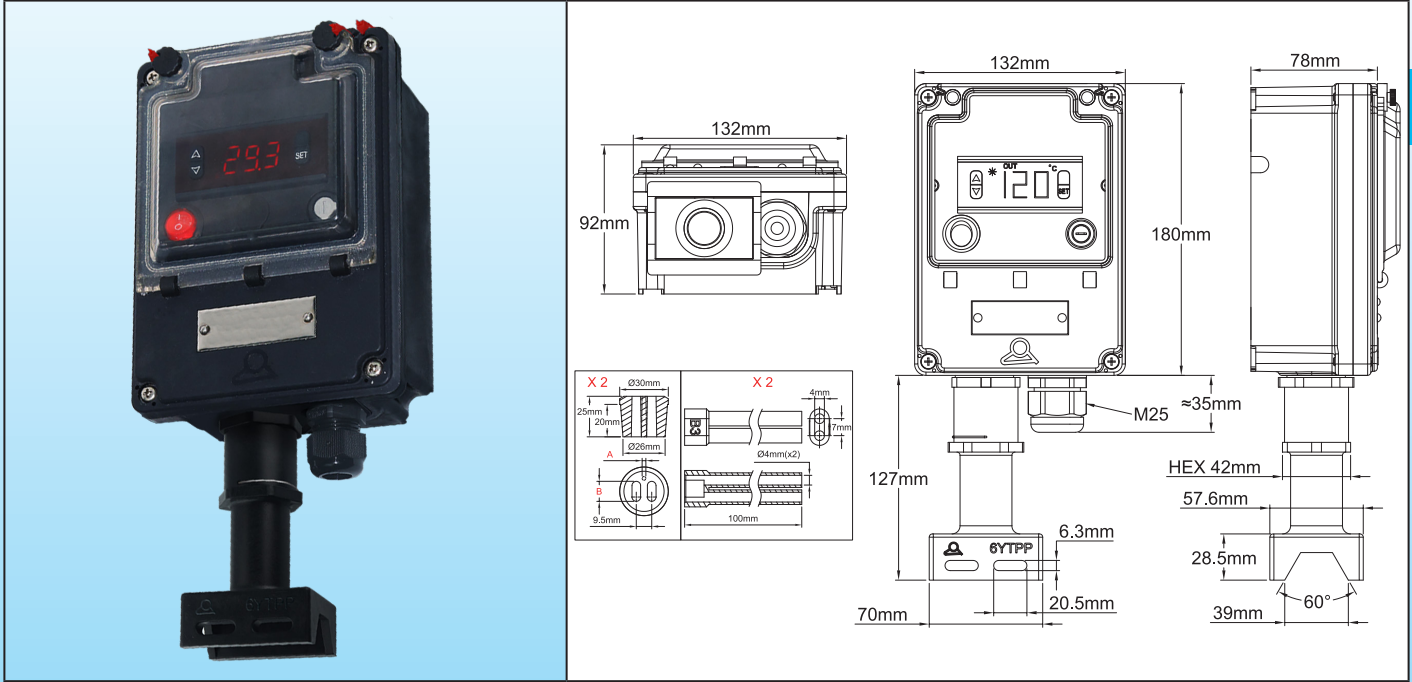

Example of assembly on pipe

Applications

These waterproof control boxes designed for **vertical mounting on pipes** allow to control the surface temperature of pipes **on site**. The connection to the heating elements and the temperature sensor is made by a pipe mounting foot incorporating the seal.

The use this model is simple. **The use of a wired temperature measurement sensor, which can be disconnected, overcomes the wall crossing problems of bulb thermostats, the capillary of which cannot be cut. Then proceeding to installation of the temperature control unit after mounting the heating cables and the temperature sensor is possible, as well as after installation of the pipe insulation and its protective sheath if they exist.**



Main features

- Enclosure:** IP69K, reinforced PA66, with polycarbonate window access. Sealable cover and window.
- Assembly:** Pipe mounting by PPS foot with heating cables crossing watertight seal. Two passages are provided in the foot for tightening it on the pipe by two nylon ties or metal hose clamps.
- Cable gland and foot:** Mounted on a removable board, facilitating assembly. This board has an M25 cable gland for the power supply cable. The heating cables exit through the foot. (The PPS foot is shipped unassembled on the box)
- Foot gasket:** Is mounted inside the foot as standard, a silicone seal designed for two heating cables and one hole for temperature sensor cable dia. 2 to 3mm. (For more information about these seals, see the catalogue page on 6YTPP pipe mounting legs)
- Accessories:** Are included two flexible boots in silicone with two bus wire funnels, length 100mm, intended to shield the conductors of the self-regulating cables after cutting off the heating zone. (For more information about these boots, see the accessories pages 6YTNB in this catalogue).
- Electrical connection:** On internal terminal block with screw terminals
- Cable gland:** One M25 cable gland for the power supply cable.
- Miscellaneous devices:** Main illuminated switch and safety fuse.
- Controller:** With very simple end-user interface. Change of set point is made without password, with up and down keys.
- Action:** On-Off with adjustable differential.
- Display:** Can be selected in °C or °F
- Sensor input:** NTC, R@25°C: 10 Kohms (±1%), B@25/50°C: 3380 (±1%).
- Power output:** 16A 230V res. relay.
- Display:** 3 digits
- Power supply:** AC 220-230V 50-60Hz.
- Accuracy:** ±1°C (±2°F) or 0.3% end of scale ± one digit.
- Self-testing:** Over-scale, under-scale, and open sensor circuit.
- Ambient temperature:** -10 to 60°C, 20 to 85% relative humidity, non-condensing.
- Options:**
 - Pt100 or K thermocouple sensor.

Part numbers, **temperature sensor not included****

Part numbers	Holes in the leg seal*		
Y8WHQ02100200AUZ	Two holes for heating cables from 11x4mm to 13x6mm and one hole for temperature sensor cable diameter 2 to 3mm (Seal reference 6YTP11).		
Y8WHQ02100100AUZ	Two holes for heating cables from 9.5x2.5mm to 11x3.5mm and one hole for temperature sensor cable diameter 2 to 3mm (Seal reference 6YTP1).		
Y8WHQ02100300AUZ	Two holes for heating cables from 8x5mm to 9.5x6mm and one hole for temperature sensor cable diameter 2 to 3mm (Seal reference 6YTP21).		

* This seal is shipped with a plug allowing to use only one heating cable
 ** For compatible temperature sensors, see the page on TNR6 products in this catalogue.

Because of permanent improvement of our products, drawings, descriptions, features used on these data sheets are for guidance only and can be modified without prior advice

Because of permanent improvement of our products, drawings, descriptions, features used on these data sheets are for guidance only and can be modified without prior advice

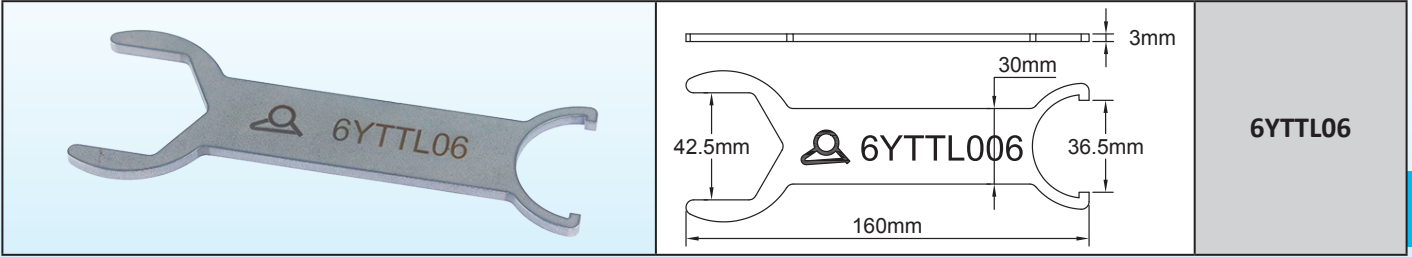

Wrench for leg assembly (To be ordered separately)

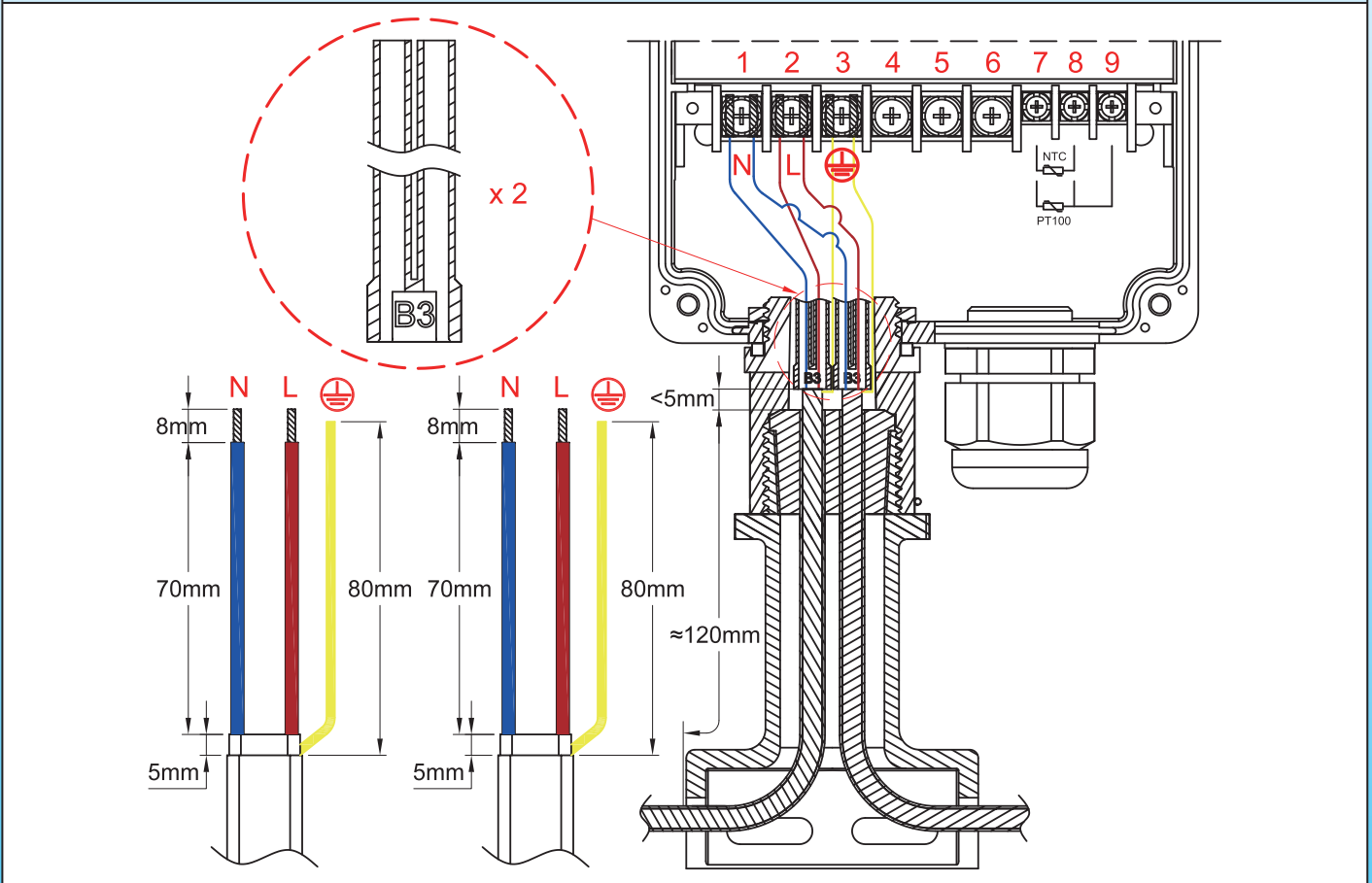

Stripping dimensions of the braided self-regulating cables

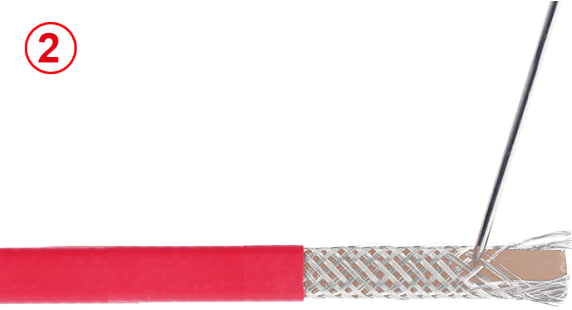

Self-regulating cables assembly steps

<p>1</p>  <p>* 6YTTL04</p> 	<p>2</p> 
<p>1: Cut the cable, remove the external jacket on the requested length</p>	<p>2: Unweave the braid on all this length with a tool with round edges or a screw driver. (For more details about this step #2, read the technical introduction).</p>

* These exclusive tools are available in accessories section

Electronic temperature controller with digital display, NTC sensor, for heat trace pipe temperature control, vertical foot mounting on pipe





Because of permanent improvement of our products, drawings, descriptions, features used on these data sheets are for guidance only and can be modified without prior advice

<p>3: Twist the braid to make a round wire</p>	<p>4: Remove the electric insulation sleeving on the requested length.</p>
<p>5: Cut and remove the heating section between the two bus wires on the requested length.</p>	<p>6: Strip off the semiconductor plastic remaining on the bus wire ends to the requested length.</p>
<p>7: Cut the stripped bus wires and the ground wire to the requested length.</p>	<p>8: Place the foot on the heating cables and on the temperature sensor cable, bringing them out from above, then slide the gasket over the cables. The outer insulating sheath must protrude from the gasket.</p>
<p>9: Fill the mouth of the silicone boot with silicone resin (RTV).</p>	<p>10: Slide the boot over the conductors of the heating cables, leaving the earth conductor outside.</p>

* These exclusive tools are available in accessories section

Electronic temperature controller with **digital display**, **NTC sensor**, for heat trace **pipe temperature control**, vertical foot mounting on pipe 

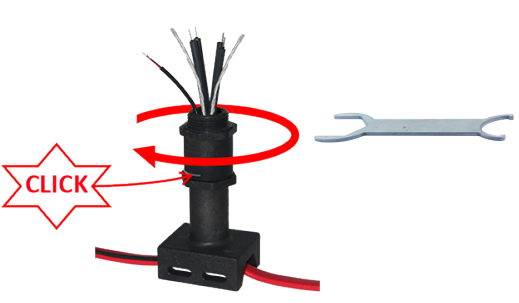
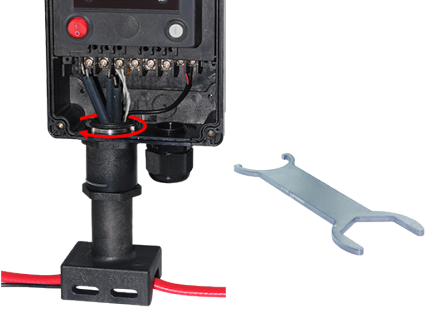
Because of permanent improvement of our products, drawings, descriptions, features used on these data sheets are for guidance only and can be modified without prior advice

	
<p>11: Compress the seal by screwing the upper part of the foot. When tightening is complete, a small spring comes to block the assembly (To disassemble, it is necessary to remove this small semi-circular spring).</p>	<p>12: Place the gasket in the upper recess of the foot, then the control unit above. Orient the housing according to the desired position, then place and tighten the toothed nut until it locks.</p>
	
<p>13: Connect the conductors and the temperature sensor according to the wiring diagram. Connect the power supply cable. Close the control box</p>	

Stripping dimensions and wiring of the power supply cable

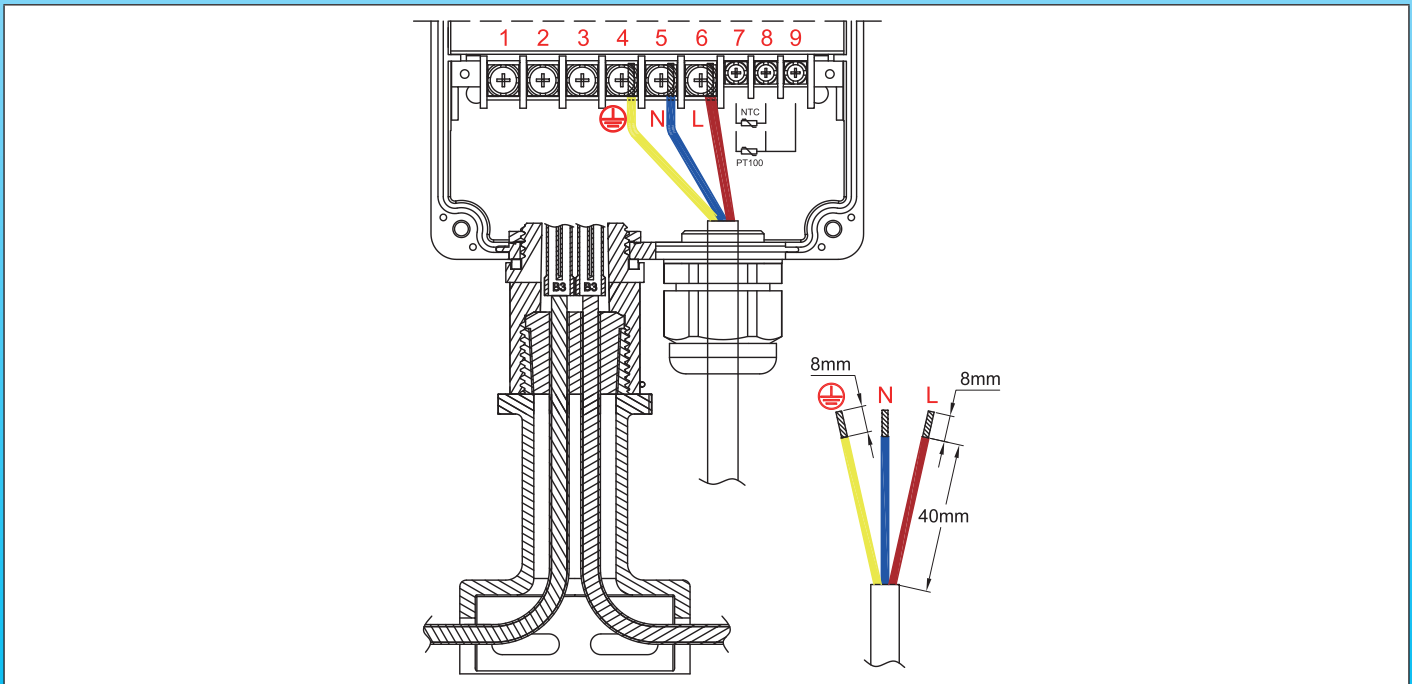



Because of permanent improvement of our products, drawings, descriptions, features used on these data sheets are for guidance only and can be modified without prior advice

The temperature sensor input is configurable, and in particular allows the **use of Pt100 RTD**

The use of a wired temperature measurement sensor, which can be disconnected, allows to overcome the problems of wall crossing of bulb thermostats, the capillary of which cannot be cut, and to proceed with installation of connection and control boxes after mounting the heating cables and the temperature sensor, installation of the pipe insulation and installation of the insulation protection sheath.

Main features

Enclosure: IP69K, reinforced PA66, with polycarbonate window access. Sealable cover and window.

Wall mounting: Four removable and rotatable legs.

Assembly: Pipe mounting by PPS foot with heating cables crossing watertight seal. Two passages are provided in the foot for tightening it on the pipe by two nylon ties or metal hose clamps.

Cable gland and foot: Mounted on a removable board, facilitating assembly. This board has an M25 cable gland for the power supply cable. The heating cables exit through the foot. (The PPS foot is shipped unassembled on the box)

Foot gasket: Is mounted inside the foot as standard, a silicone seal designed for two heating cables and one hole for temperature sensor cable dia. 2 to 3mm. (For more information about these seals, see the catalogue page on 6YTPP pipe mounting legs)

Accessories: Are included two flexible boots in silicone with two bus wire funnels, length 100mm, intended to shield the conductors of the self-regulating cables after cutting off the heating zone. (For more information about these boots, see the accessories pages 6YTNB in this catalogue).

Electrical connection: On internal terminal block with screw terminals

Cable gland: One M25 cable gland for the power supply cable.

Switching devices: Main illuminated switch and safety fuse

Controller: Double display, of process value and of set-point

Action: PID with automatic parameters adjustment by auto-tune function. It can also be set in ON-OFF action with adjustable differential

Sensor input: Configurable for Pt100, K thermocouple and other sensors

Power output: 20A 230V solid state relay.

Alarm: 3A 230V relay.

Display: 4 digits display configurable in °C or °F

Power supply: AC 220-230V 50-60Hz.

Accuracy: ±1°C (±2°F) or 0.3% end of scale ± one digit.

Self-testing: Over-scale, under-scale, and open sensor circuit.

Ambient temperature: -10 to 60°C, 20 to 85% relative humidity, non-condensing.

Part numbers, **temperature sensor not included****

References	Holes in the leg seal*
Y8WJU021D0200AUZ	
Y8WJU021D0100AUZ	
Y8WJU021D0300AUZ	

* This seal is shipped with a plug allowing to use only one heating cable.

** For compatible temperature sensors, see the page on TSR5 products in this catalogue.



Wrench for leg assembly (To be ordered separately)

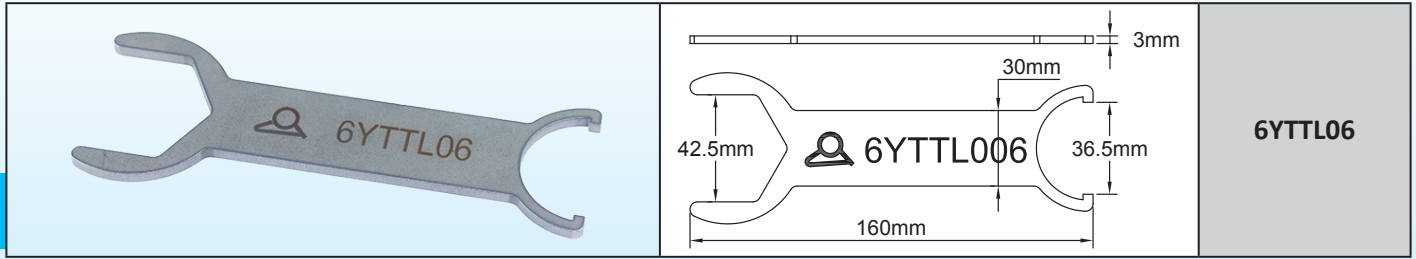

Stripping dimensions of the braided self-regulating cables

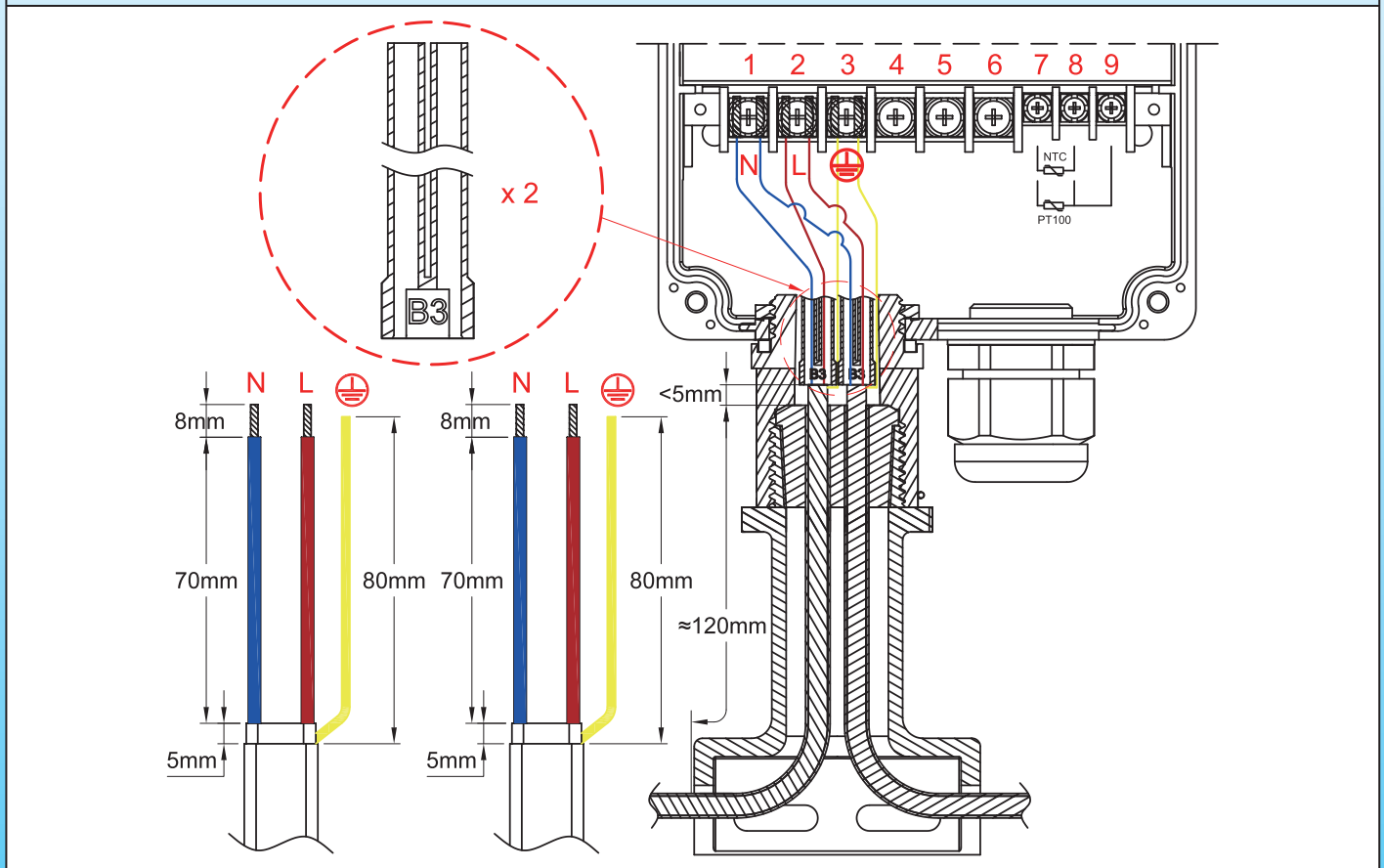

Self-regulating cables assembly steps







<p>1</p> <p>* 6YTTL04</p>	<p>2</p>
<p>1: Cut the cable, remove the external jacket on the requested length</p>	<p>2: Unweave the braid on all this length with a tool with round edges or a screw driver. (For more details about this step #2, read the technical introduction).</p>

* These exclusive tools are available in accessories section

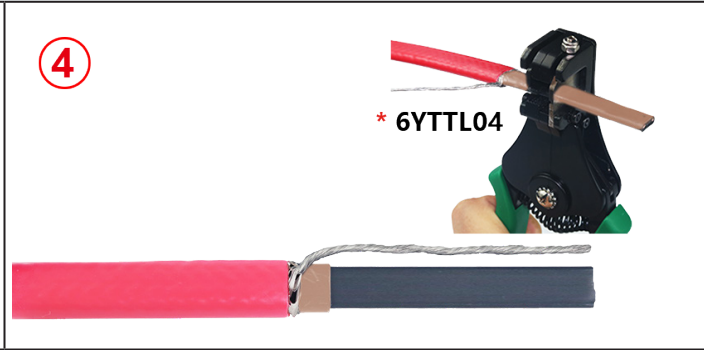
Electronic temperature controller with **double digital display, multi-sensors, PID or ON-OFF action**, for heat trace **pipe temperature control, vertical foot mounting on pipe**

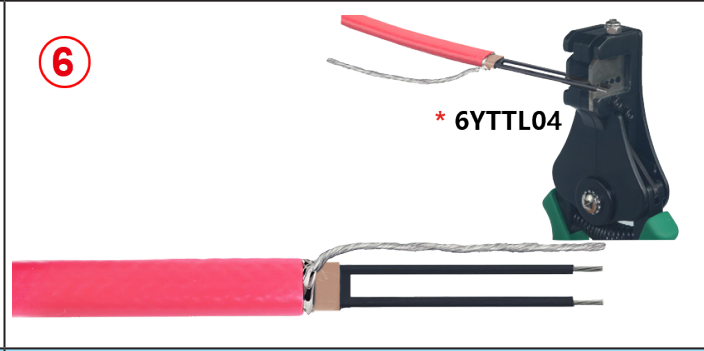

Because of permanent improvement of our products, drawings, descriptions, features used on these data sheets are for guidance only and can be modified without prior advice

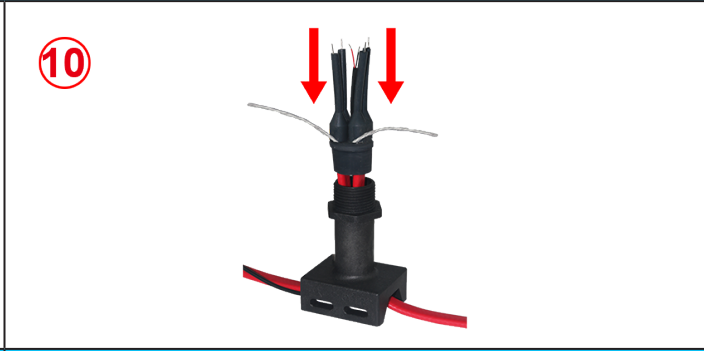
	
<p>3: Twist the braid to make a round wire.</p>	<p>4: Remove the electric insulation sleeving on the requested length.</p>
	
<p>5: Cut and remove the heating section between the two bus wires on the requested length.</p>	<p>6: Strip off the semiconductor plastic remaining on the bus wire ends to the requested length.</p>
	
<p>7: Cut the stripped bus wires and the ground wire to the requested length.</p>	<p>8: Place the foot on the heating cables and on the temperature sensor cable, bringing them out from above, then slide the gasket over the cables. The outer insulating sheath must protrude from the gasket.</p>
	
<p>9: Fill the mouth of the silicone boot with silicone resin (RTV).</p>	<p>10: Slide the boot over the conductors of the heating cables, leaving the earth conductor outside.</p>

* These exclusive tools are available in accessories section



<p>11</p>	<p>12</p>
<p>11: Compress the seal by screwing the upper part of the foot. When tightening is complete, a small spring comes to block the assembly (To disassemble, it is necessary to remove this small semi-circular spring)</p>	<p>12: Place the gasket in the upper recess of the foot, then the control unit above. Orient the housing according to the desired position, then place and tighten the toothed nut until it locks.</p>
<p>13</p>	
<p>13: Connect the conductors and the temperature sensor according to the wiring diagram. Connect the power supply cable. Close the control box.</p>	

Stripping dimensions and wiring of the power supply cable

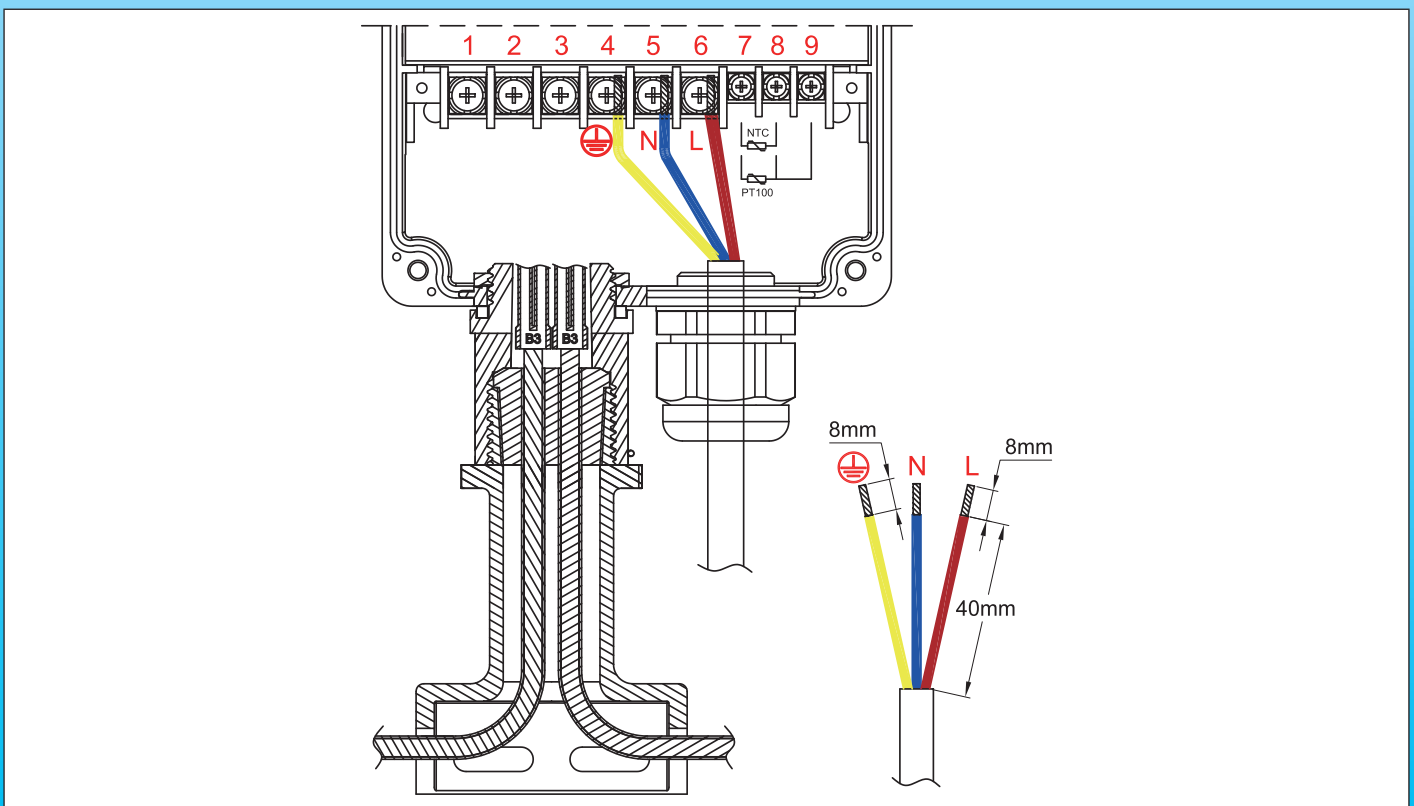

Temperature sensors: **100 Ohms platinum RTD, dia. 5mm × 30mm stainless steel probe** for use in heat tracing.



Because of permanent improvement of our products, drawings, descriptions, features used on these data sheets are for guidance only and can be modified without prior advice

Temperature range	Cable insulation	Probe protection	Temperature sensing device	Signal type	Type
20- 200°C (120- 390°F)	FEP	Stainless steel probe, dia.5mm × 30mm	Pt100 platinum resistance	Ohms, linear	TSR5

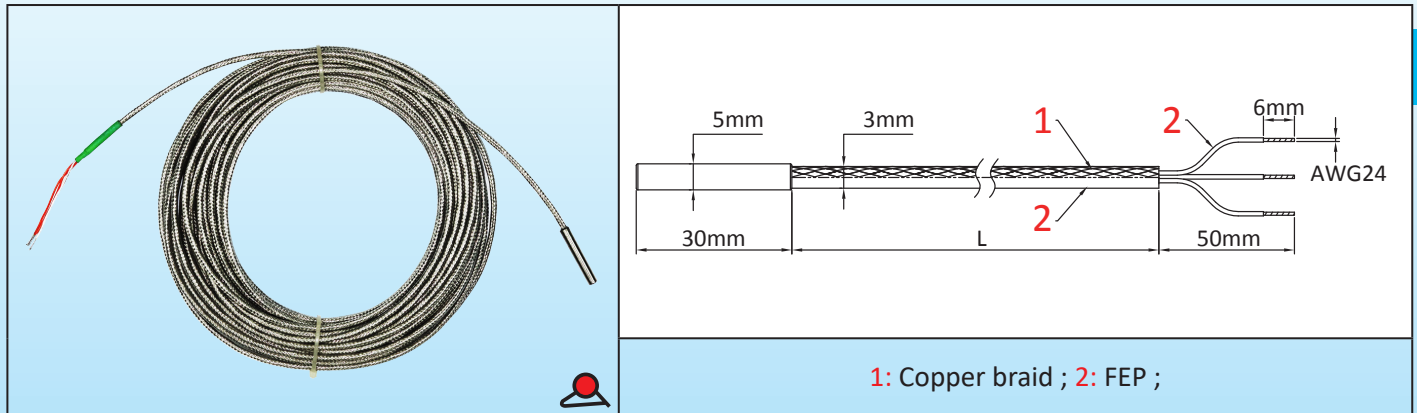

1: Copper braid ; 2: FEP ;

Main applications

The main advantage of these PT100 sensors in the temperature measurement of flexible heating elements is their robustness. Because of their small size, they can be glued or incorporated into flexible flat elements. They are resistant to shocks and vibrations, but their reaction time is longer, and they are more expensive than models with encapsulated measuring element.

Main features

The platinum resistivity has excellent repeatability, and high accuracy over an extended temperature range. The resistance variation curve of platinum as a function of temperature is much more linear than that of thermocouples or thermistors. Electronic controllers using Pt100 are simpler and less expensive than thermocouple ones. In addition, they do not need temperature-compensated cable such as thermocouples. Pt100 are used worldwide and are interchangeable, using the DIN 43760 curve.

Construction: A platinum film is deposited on a ceramic substrate, conductors are welded to it, and the whole is inserted in a stainless-steel protection probe.

Mounting: The end with the measuring element Pt100 is then fixed on the flexible heating element with a protective cap of type 9BFS3, 9BFM1, or 9BFV2 (see technical pages on the silicone caps), which can be vulcanised or glued.

Temperature range: Use temperature limited to 200°C due to FEP insulated cable.

Accuracy and tolerances:

- Nominal value at 0°C: 100 Ohms.
- Nominal value at 100°C: 138.51 Ohms

The international standard IEC 751-1983 and DIN EN 60751 2009-05 give the parameters of the temperature response curve.

Class B, the most common, has a tolerance of ± 0.3°C at 0°C. (± 0.12 Ω at 0°C).

Color Code: The two red wires are connected together to their solder on one of the terminals of the ceramic substrate, and the white wire is connected to the other terminal.

Cable composition: 3 × 0.35mm², (AWG24), FEP insulation + braid + FEP sleeving, T 200°C, O.D. 3mm

Main parts numbers (Accuracy class B)

Part number	Cable length (mm)
TSR50030I0200BK6	200
TSR50030I0500BK6	500
TSR50030I1000BK6	1000
TSR50030I2000BK6	2000
TSR50030I3000BK6	3000

Note: These temperature sensors are not manufactured by Ultimheat, and the information given is that of our suppliers.

Temperature sensors: **10 kohms NTC**,
dia. 6mm × 30mm nickel plated copper probe for use in heat tracing.



Temperature range	Cable insulation	Probe protection	Temperature sensing device	Signal type	Type
20 - 120°C (68 - 390°F)	FEP	Nickel plated copper probe, dia.6mm × 30mm	10 Kohms thermistor	Ohms Logarithmic	TNR6

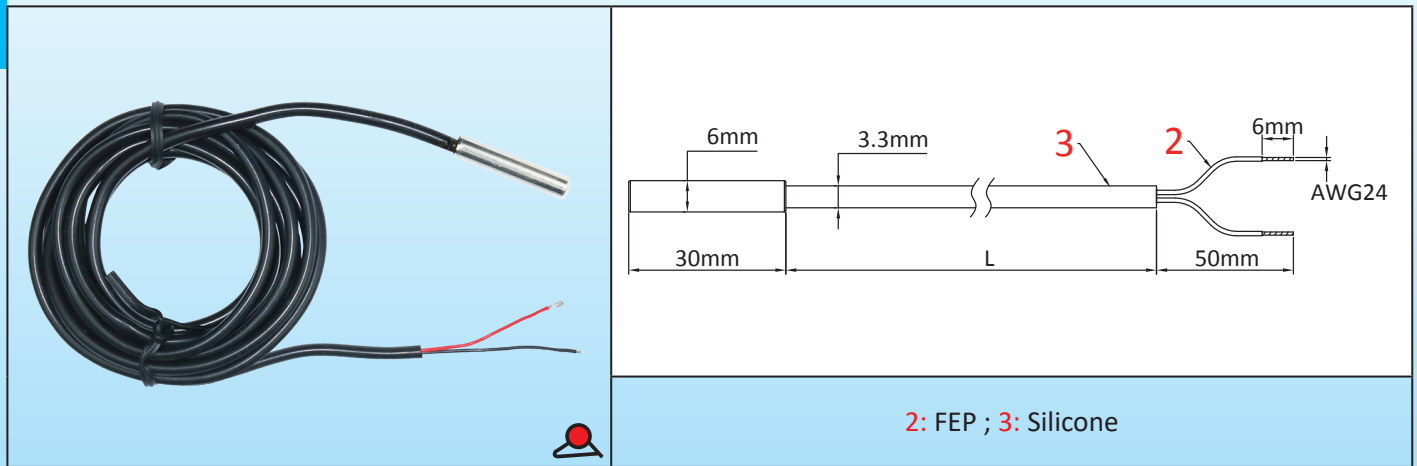

Main applications

The main advantage of these NTC sensors in the temperature measurement of flexible heating elements is their robustness and a relatively short response time. Because of their small size, they can be glued or incorporated into flexible flat elements. They are resistant to shocks and vibrations, but their temperature resistance is limited.

Main features

The thermistor is particularly economical. Its accuracy is correct for temperature ranges from 0 to 120°C. Its resistance decreases logarithmically with temperature. Its repeatability is good, but the interchangeability of the sensors between different suppliers is average. This is the reason why most electronic controllers using these thermistor sensors have a zero-correction system. These regulators are generally simple and inexpensive.

Construction: The measuring element is a glass bead encasing the sintered alloy with a negative temperature coefficient, from which two wires emerge. The conductors of the connecting cable are welded therein, and the assembly is inserted into a nickel-plated copper protection tube with low thermal inertia.

Mounting: The end with the NTC measuring element is then attached to the flexible heating element with a protective cap of type 9BFS4, 9BFM2 or 9BFV3 (see technical pages on silicone caps), which can be vulcanized or bonded.

Temperature range: The operating temperature is limited to 120°C.

Accuracy and tolerances:

- Nominal value at 25°C: 10 Kohms ± 1%. B = 3380 ± 1%

Color Code: The two conductors are identical in color and each corresponds to one of the terminals of the thermistor. Due to the high resistance of the measuring element, a third conductor is not necessary.

Composition of the cable: 2 × 0.35mm², (AWG24) silicone insulation with FEP sleeving, outer diameter 3.3mm.

Main parts numbers (accuracy class 1%)

Part number	Cable length (mm)
TNR60030C02001F4	200
TNR60030C05001F4	500
TNR60030C10001F4	1000
TNR60030C20001F4	2000
TNR60030C30001F4	3000

Note: These temperature sensors are not manufactured by Ultimheat, and the information given is that of our suppliers.

Because of permanent improvement of our products, drawings, descriptions, features used on these data sheets are for guidance only and can be modified without prior advice



Main features

Pt 100 3 wires RTD temperature sensor:

- Connection: 3 wires 0.5mm² (AWG24), FEP insulation + metallic braid + FEP. The 2 white wires are connected to one pole of the Pt100, the red wire to the other pole.

Negative temperature coefficient (NTC) thermistor temperature sensor:

- Connection: Black 2 wires 0.5mm² cable (AWG24), FEP + Silicone insulation. A black wire, a red wire. Each of these wires corresponds to a pole of the thermistor. Resistance variation curve: value 10 Kilo-ohms at 25°C, coefficient B 3380.

K thermocouple sensor:

- Connection: Green 2 wire 0.5mm² cable (AWG24), FEP + FEP insulation. Colour code according to IEC 584-3. The white wire is negative, the green wire is positive. (Colour code upon other standards on request).

J thermocouple sensor:

- Connection: Black 2 wire 0.5mm² cable (AWG24), FEP + FEP insulation. Colour code according to IEC 584-3. The white wire is negative, the black wire is positive. (Colour code upon other standards on request).

Accessoires:

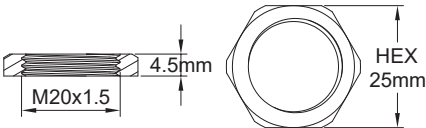
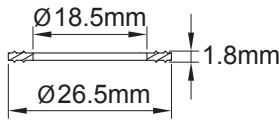
M20 x1.5 Nylon nut		66NDM20545H25
70 shore NBR gasket		66JPN18518265

References

Sensor type	Cable length (L)			
	300mm	1m	2m	3m
Pt100	TSJBD150A0302BK6	TSJBD150A1002BK6	TSJBD150A2002BK6	TSJBD150A3002BK6
NTC (10 Kohms @ 25°C)	TNJBD150A03022F6	TNJBD150A10022F6	TNJBD150A20022F6	TNJBD150A30022F6
Thermocouple K	TPJBD150A03022D6	TPJBD150A10022D6	TPJBD150A20022D6	TPJBD150A30022D6
Thermocouple J	TJJBD150A03022D6	TJJBD150A10022D6	TJJBD150A20022D6	TJJBD150A30022D6

Because of permanent improvement of our products, drawings, descriptions, features used on these data sheets are for guidance only and can be modified without prior advice



Section 8

Various assemblies made on heating cables **supplied by customer**



Why we make assemblies on heating wires supplied by customers?

- We have the knowledge of the multiple techniques for connecting heating cables and we use the technique most suited to each model.
- Our state-of-the-art industrial equipment, with the production of hundreds of thousands of various cable connections each year, is generally more efficient than that available to our customers.
- Thanks to this equipment, assembly times and costs are greatly reduced.
- The finish is professional and the operation is guaranteed and tested.

Thermostats **overmolded** on heat tracing cables supplied by customer



Because of permanent improvement of our products, drawings, descriptions, features used on these data sheets are for guidance only and can be modified without prior advice

Heating cable type	Plug style	Cord length	Cables gauge	Set point		Type
Self-regulating, constant power, Serial	Euro UL	2m 3m	2 × 0.75mm ² 2 × 1mm ² 3 × 1mm ² 3 × 1.5mm ²	4±3°C		49C

A: Plug (Model depends of country)
B: Power supply cable
C: PA66 overmolding on the power supply cord
D: Heating cable (Supplied by customer)
E: PA66 overmolding of the cable termination
F: Fixed temperature setting disc thermostat

Applications

This system allows to make a set comprising a power supply cord, a heating cable and an anti-freeze thermostat in a **professional, waterproof and economical manner**. Overmolding a disc thermostat on a heating cable allows to switch it on when the ambient temperature falls below a certain threshold, and to switch it off when the temperature rises. Overmolding improves the mechanical strength of the assembly and provides a superior ingress protection to water. **Thanks to the special process developed in our laboratories, Polyamide 66 injection molding does not overheat the disc of the thermostat, avoiding in this way the set point temperature drift that this operation usually brings. The production is carried out in the factory only, with the heating cable supplied by the customer.** It is compatible with all types of flat or round heating cables of the self-regulating parallel type or of constant power, or of the serial type with two conductors side by side. The cable may or may not include a metal braid and an outer jacket. The plug is variable depending on the country of destination, the voltage, the intensity and the number of conductors. A MOQ of 1000 pieces is required.

Main features

- Material:** Overmolding in flexible black polyamide. Excellent UV resistance.
- Part sensitive to temperature:** Stainless steel cup, not over molded to improve temperature measurement.
- Ingress protection:** IP67
- Contact:** Open by temperature rise.
- Electrical rating:**
 - 10A Resistive, 250V AC, 100,000 cycles, or 16A Resistive, 250V AC, 30,000 cycles
- Temperature calibration:** Contact opens at 10±3°C and closes at 4±3°C. Contact us for other temperatures.
- Power supply cord:**
 - For heating cables **with** metal braid: Three conductors, type H05VVF (PVC insulation), with European or US overmolded plug. Section depending on the power of the heating cable used.
 - For heating cables **without** metal braid: Two conductors, type H05VVF (PVC insulation), with European or US overmolded plug without earth. Section depending on the power of the heating cable used.
- Connection of heating cable:** **This device is over-molded on heating cable supplied by the customer only. The molding tools are then adapted to the dimensions of cables.**
- Options:**
 - Other thermostat set point calibration
 - Blister or customer packaging
 - Other style of plug (UK, Japan, Australia).
 - Other type of cable insulation (Rubber, Rubber + PVC).

Thermostats **overmolded** on heat tracing cables supplied by customer

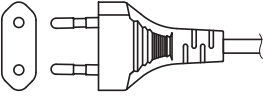
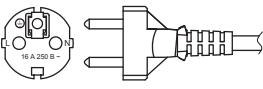
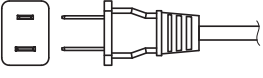
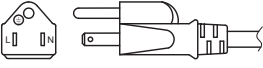

Main part numbers (with thermostat opens at 10±3°C and closes at 4±3°C)

Type	Plug	Maximum rating	Cable gauge	Cord length	Part number
 4	Europe (CEE 7/16 "Europlug")	6A 250V	2 × 0.75mm ²	2m	49C0 TT PPP8 LLLA 4
	Europe (CEE 7/16 "Europlug")	6A 250V	2 × 0.75mm ²	3m	49C0 TT PPP8 LLLB 4
	Europe (CEE 7/16 "Europlug")	6A 250V	2 × 1mm ²	2m	49C0 TT PPP8 LLLC 4
	Europe (CEE 7/16 "Europlug")	6A 250V	2 × 1mm ²	3m	49C0 TT PPP8 LLLD 4
 1	Europe (CEE 7/7)	10A 250V	3 × 1mm ²	2m	49C0 TT PPP8 LLLE 1
	Europe (CEE 7/7)	10A 250V	3 × 1mm ²	3m	49C0 TT PPP8 LLLF 1
	Europe (CEE 7/7)	16A 250V	3 × 1.5mm ²	2m	49C0 TT PPP8 LLLG 1
	Europe (CEE 7/7)	16A 250V	3 × 1.5mm ²	3m	49C0 TT PPP8 LLLH 1
 3	USA (Nema 1/15)	10A 125V	2 × AWG18 (2 × 0.75mm ²)	2m	49C0 TT PPP8 LLLJ 3
	USA (Nema 1/15)	10A125V	2 × AWG18 (2 × 0.75mm ²)	3m	49C0 TT PPP8 LLLK 3
 2	USA, Canada (NEMA 5-15)	10A 125V	3 × AWG18 (3 × 0.75mm ²)	2m	49C0 TT PPP8 LLLL 2
	USA, Canada (NEMA 5-15)	10A 125V	3 × AWG18 (3 × 0.75mm ²)	3m	49C0 TT PPP8 LLLM 2
	USA, Canada (NEMA 5-15)	13A 125V	3 × AWG16 (3 × 1.25mm ²)	2m	49C0 TT PPP8 LLLN 2
	USA, Canada (NEMA 5-15)	13A 125V	3 × AWG16 (3 × 1.25mm ²)	3m	49C0 TT PPP8 LLLP 2
	USA, Canada (NEMA 5-15)	15A 125V	3 × AWG14 (3 × 2mm ²)	2m	49C0 TT PPP8 LLLQ 2
	USA, Canada (NEMA 5-15)	15A 125V	3 × AWG14 (3 × 2mm ²)	3m	49C0 TT PPP8 LLLR 2

TT: Variable characters, depends of the type of cable supplied by the customer (Self-regulating with PE core, self-regulating with silicone core, constant power, serial with 2 conductors side by side, with or without braid or grounding ribbon, etc.).

PPP: Total cable power in decawatts.

V: Supply voltage, with 8 = 230V (220-240V) and 6 = 115V (110-120V).



LLL: length L2 of the heating cable in decimetres.

Because of permanent improvement of our products, drawings, descriptions, features used on these data sheets are for guidance only and can be modified without prior advice

Overmolding of terminations heating cable supplied by customer



Because of permanent improvement of our products, drawings, descriptions, features used on these data sheets are for guidance only and can be modified without prior advice

Heating cable type	Plug style	Cord length	Cables gauge		Type
Self-regulating, constant power, Serial	Euro UL	2m 3m	$2 \times 0.75\text{mm}^2$ $2 \times 1\text{mm}^2$ $3 \times 1\text{mm}^2$ $3 \times 1.5\text{mm}^2$		

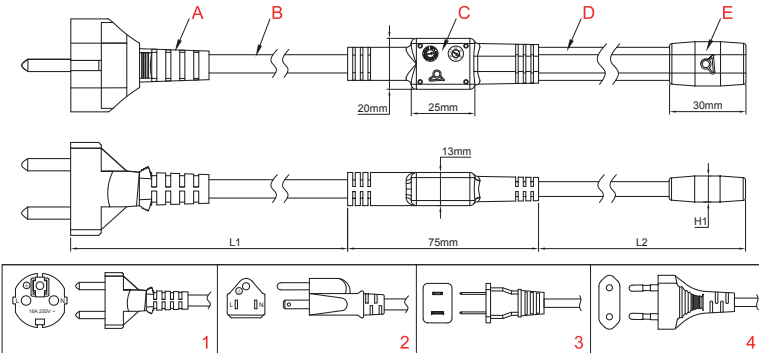
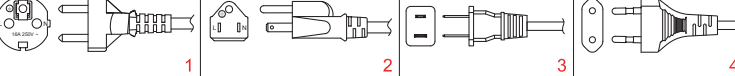
	
	
<p>A: Plug (Model depends of country) B: Power supply cable C: PA66 overmolding on the power supply cord D: Heating cable (Supplied by customer) E: PA66 overmolding of the cable termination</p>	

Applications

This system makes it possible to produce a set comprising a power cable and a heating cable in a **professional, waterproof and economical manner. The production is carried out in the factory only, with the heating cable supplied by the customer.**

It is compatible with all types of flat or round heating cables of the self-regulating parallel type or of constant power, or of the serial type with two conductors side by side. The cable may or may not include a metal braid and an outer jacket. The plug is variable depending on the country of destination, the voltage, the intensity and the number of conductors.

A minimum of production of 1000 pieces is required.

Main features

Material: Overmolding in flexible black polyamide. Excellent UV resistance.

Waterproof: IP67

Power supply cord:

- For heating cables **with** metal braid: Three conductors, type H05VVF (PVC insulation), with European or US overmolded plug. Section depending on the power of the heating cable used.

- For heating cables **without** metal braid: Two conductors, type H05VVF (PVC insulation), with European or US overmolded plug without earth. Section depending on the power of the heating cable used.

Options:

- Blister or customer packaging
- Other style of plug (UK, Japan, Australia).
- Other type of cable insulation (Rubber, Rubber + PVC).

Overmolding of terminations heating cable supplied by customer

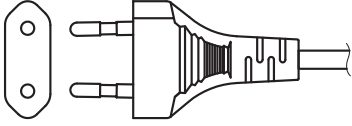
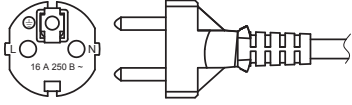
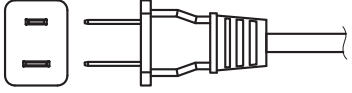
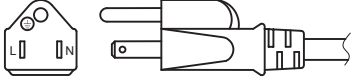

Main part numbers

Type	Plug	Maximum rating	Cable gauge	Cord length	Part number
 4	Europe (CEE 7/16 "Europlug")	6A 250V	2 × 0.75mm ²	2m	9UW TT PPPP8 LLLA 4
	Europe (CEE 7/16 "Europlug")	6A 250V	2 × 0.75mm ²	3m	9UW TT PPPP8 LLLB 4
	Europe (CEE 7/16 "Europlug")	6A 250V	2 × 1mm ²	2m	9UW TT PPPP8 LLLC 4
	Europe (CEE 7/16 "Europlug")	6A 250V	2 × 1mm ²	3m	9UW TT PPPP8 LLLD 4
 1	Europe (CEE 7/7)	10A 250V	3 × 1mm ²	2m	9UW TT PPPP8 LLLE 1
	Europe (CEE 7/7)	10A 250V	3 × 1mm ²	3m	9UW TT PPPP8 LLLF 1
	Europe (CEE 7/7)	16A 250V	3 × 1.5mm ²	2m	9UW TT PPPP8 LLLG 1
	Europe (CEE 7/7)	16A 250V	3 × 1.5mm ²	3m	9UW TT PPPP8 LLLH 1
 3	USA (Nema 1/15)	10A 125V	2 × AWG18 (2 × 0.75mm ²)	2m	9UW TT PPPP8 LLLJ 3
	USA (Nema 1/15)	10A125V	2 × AWG18 (2 × 0.75mm ²)	3m	9UW TT PPPP8 LLLK 3
 2	USA, Canada (NEMA 5-15)	10A 125V	3 × AWG18 (3 × 0.75mm ²)	2m	9UW TT PPPP8 LLLL 2
	USA, Canada (NEMA 5-15)	10A 125V	3 × AWG18 (3 × 0.75mm ²)	3m	9UW TT PPPP8 LLLM 2
	USA, Canada (NEMA 5-15)	13A 125V	3 × AWG16 (3 × 1.25mm ²)	2m	9UW TT PPPP8 LLLN 2
	USA, Canada (NEMA 5-15)	13A 125V	3 × AWG16 (3 × 1.25mm ²)	3m	9UW TT PPPP8 LLLP 2
	USA, Canada (NEMA 5-15)	15A 125V	3 × AWG14 (3 × 2mm ²)	2m	9UW TT PPPP8 LLLQ 2
	USA, Canada (NEMA 5-15)	15A 125V	3 × AWG14 (3 × 2mm ²)	3m	9UW TT PPPP8 LLLR 2

TT: Variable characters, depends of the type of cable supplied by the customer (Self-regulating with PE core, self-regulating with silicone core, constant power, serial with 2 conductors side by side, with or without braid or grounding ribbon, etc.).

PPPP: Total cable power in watts.

V: Supply voltage, with 8 = 230V (220-240V) and 6 = 115V (110-120V).

LLL: Length L2 of the heating cable in decimetres.

Because of permanent improvement of our products, drawings, descriptions, features used on these data sheets are for guidance only and can be modified without prior advice



Because of permanent improvement of our products, drawings, descriptions, features used on these data sheets are for guidance only and can be modified without prior advice

Section 9

Heating cables terminations and small accessories



Silicone molded parts

- We have developed a range covering the various applications in heating cables, because this solution is often the most economical and easy to implement.
- Molding ourselves flexible silicone caps for over 10 years to protect electrical connections in electrothermal applications, our experience allows us to offer effective technical solutions.

Small accessories

- The complete integration in our factory of the cutting, stamping and welding operations of the stainless steel parts is at the origin of the various accessories for fixing the boxes and the heating cables.

Overmolded cord with built in anti-freeze thermostat. For use on oblong **parallel type** heating cables, **self-regulating or constant power**. Connection by crimping or soldering.
Insulation by shrinkable sleeve



Because of permanent improvement of our products, drawings, descriptions, features used on these data sheets are for guidance only and can be modified without prior advice

Temperature	Plug style	Cord length	Cables gauge		Type
Open $10^{\circ}\text{C} \pm 3^{\circ}\text{C}$ Close $4^{\circ}\text{C} \pm 3^{\circ}\text{C}$	Euro UL	2m 3m	$3 \times 1\text{mm}^2$ $3 \times 1.5\text{mm}^2$		

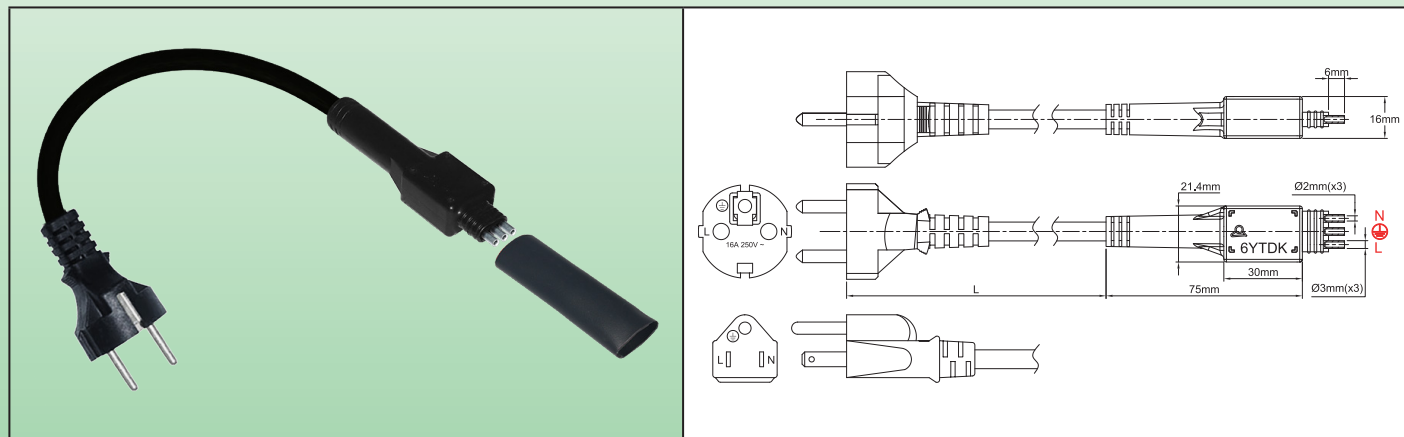

Applications

This system allows to **professionally, waterproof and economically** connect a power cord including a frost protection fixed temperature thermostat on a heating cable. **Assembly is possible on the field or in the workshop**, and does not require special tools.

It is compatible with all types of flat or round parallel heating cables. It is particularly suitable for domestic installations for frost protection of meters, pumps, pipes.

Main features

Material: Thermostat body overmolded in black polyamide. Excellent UV resistance.

Thermostat: Electrical rating 16A 230V, contact opens by temperature rise to $10^{\circ}\text{C} \pm 3^{\circ}\text{C}$, closes by temperature drop to $4^{\circ}\text{C} \pm 3^{\circ}\text{C}$. (Other temperatures on request)

Water resistance: IP66

Fixing: Can be fixed on a tube using a nylon hose clamp.

Connection cord: Type H05VVF (PVC insulation) with three conductors, with European or US overmolded plug. (Other models possible with minimum order). Gauge $3 \times 1\text{mm}^2$ or $3 \times 1.5\text{mm}^2$ depending on the power of the heating cable used.

Options:

- Custom OEM versions
- Other style of plug (UK, Japan, Australia).
- Other type of cable insulation (Rubber, Rubber + PVC).
- Cable and plug without earth conductor.

Main part numbers

Plug	Cable gauge	Cord length	Part numbers *
Europe (CEE 7/7, 16A)	$3 \times 1\text{mm}^2$	2m	6YTDKABPE2001060
Europe (CEE 7/7, 16A)	$3 \times 1.5\text{mm}^2$	2m	6YTDKAAPE2001060
Europe (CEE 7/7, 16A)	$3 \times 1\text{mm}^2$	3m	6YTDKABPE3001060
Europe (CEE 7/7, 16A)	$3 \times 1.5\text{mm}^2$	3m	6YTDKAAPE3001060
USA, Canada (NEMA 5-15, 3 Pin - 15 Amp)	$3 \times 1\text{mm}^2$	2m	6YTDKABPU2001060
USA, Canada (NEMA 5-15, 3 Pin - 15 Amp)	$3 \times 1.5\text{mm}^2$	2m	6YTDKAAPU2001060
USA, Canada (NEMA 5-15, 3 Pin - 15 Amp)	$3 \times 1\text{mm}^2$	3m	6YTDKABPU3001060
USA, Canada (NEMA 5-15, 3 Pin - 15 Amp)	$3 \times 1.5\text{mm}^2$	3m	6YTDKAAPU3001060

* Double wall shrinkable sleeve **not included**.

Overmolded cord with built in anti-freeze thermostat. For use on oblong **parallel type** heating cables, **self-regulating or constant power**. Connection by crimping or soldering.
Insulation by shrinkable sleeve



Heating cable wiring dimensions

(See the technical introduction for the cable end stripping operations, which are different depending of the model of the cable)

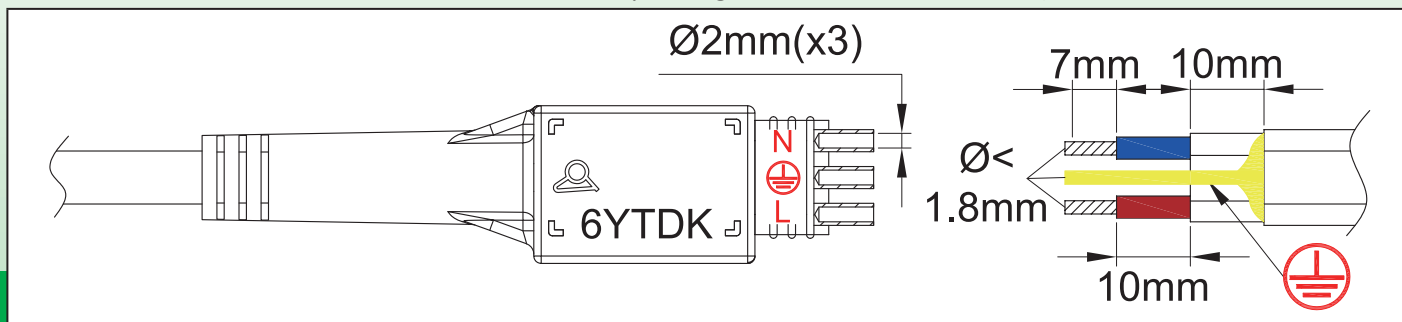

Assembly steps of the thermostatic cord on self-regulating cable

(See the technical introduction for constant power cable)

<p>1</p> <p>* 6YTTL04</p>	<p>2</p>
<p>1: Strip the outer jacket of the heating cable to the required length.</p>	<p>2: Unweave the braid on all this length with a tool with round edges or a screw driver. (For more details about this step #2, read the technical introduction).</p>
<p>3</p>	<p>4</p>
<p>3: Twist the braid to make a round wire.</p>	<p>4: Check that ground conductor diameter is smaller than 1.8mm. If more than this value, trim some small wires.</p>
<p>5</p> <p>* 6YTTL04</p>	<p>6</p> <p>* 6YTTL04</p>
<p>5: Remove the electric insulation sleeve on the requested length.</p>	<p>6: Cut and remove the heating section between the two bus wires on the requested length.</p>

* These exclusive tools are available in accessories section

Overmolded cord with built in anti-freeze thermostat. For use on oblong **parallel type** heating cables, **self-regulating or constant power**. Connection by crimping or soldering.
Insulation by shrinkable sleeve



Because of permanent improvement of our products, drawings, descriptions, features used on these data sheets are for guidance only and can be modified without prior advice

<p>7</p> <p>* 6YTTL04</p>	<p>8</p>
<p>7: Strip off the semiconductor plastic remaining on the bus wire ends to the requested length.</p>	<p>8: Cut the conductors and the earth wire of the heating cable to the same length</p>
<p>9</p>	<p>10</p>
<p>9: Slide a double wall shrinkable tube on the heating cable.</p>	<p>10: Insert wires inside the tubular terminals, and crimp or tin solder them.</p>
<p>11</p>	<p>12</p>
<p>11: Slide the shrinkable tube over the thermostat body ribs.</p>	<p>12: Shrink the sleeve with hot air gun.</p>

* These exclusive tools are available in accessories section

Overmolded cord with built in anti-freeze thermostat. For use on oblong **parallel type** heating cables, **self-regulating or constant power**. Connection by crimping or soldering.
Insulation by silicone boot with RTV filling



Temperature	Plug style	Cord length	Cables gauge		Type
Open $10^{\circ}\text{C} \pm 3^{\circ}\text{C}$ Close $4^{\circ}\text{C} \pm 3^{\circ}\text{C}$	Euro UL	2m 3m	$3 \times 1\text{mm}^2$ $3 \times 1.5\text{mm}^2$		6YTDKB

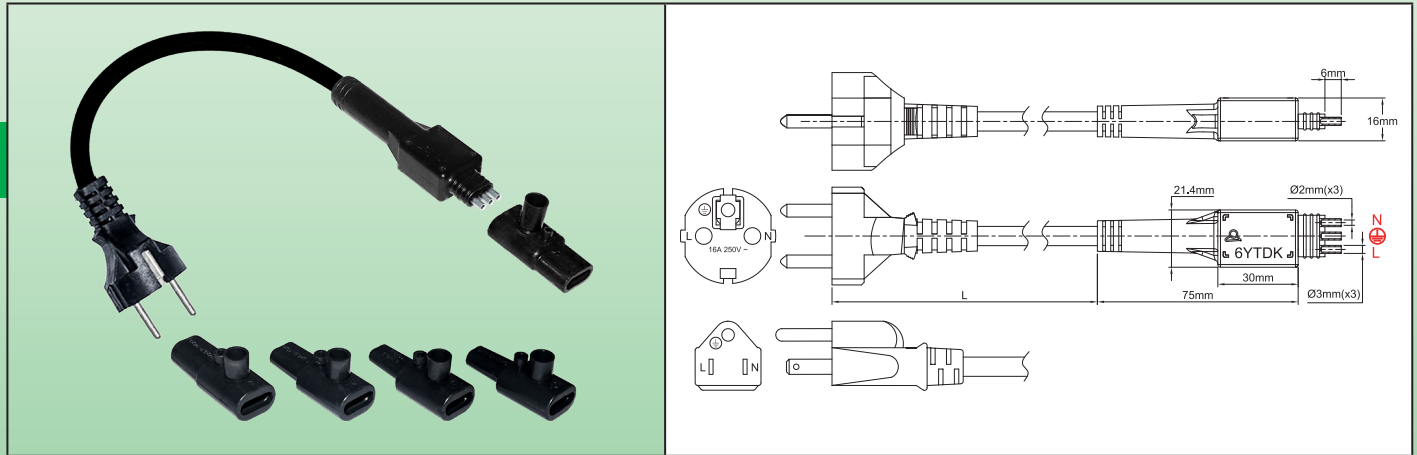

Applications

This system allows to **professionally, waterproof and economically** connect a power cord including a frost protection fixed temperature thermostat on a heating cable. **Assembly is possible on the field or in the workshop**, and does not require special tools.

It is compatible with all types of flat or round parallel heating cables. It is particularly suitable for domestic installations for frost protection of meters, pumps, pipes.

Main features

Material: Thermostat body overmolded in black polyamide. Excellent UV resistance.

Thermostat: Electrical rating 16A 230V, contact opens by temperature rise to $10^{\circ}\text{C} \pm 3^{\circ}\text{C}$, closes by temperature drop to $4^{\circ}\text{C} \pm 3^{\circ}\text{C}$. (Other temperatures on request)

Water resistance: IP66

Fixing: Can be fixed on a tube using a nylon hose clamp.

Connection cord: Type H05VVf (PVC insulation) with three conductors, with European or US overmolded plug. (Other models possible with minimum order). Gauge $3 \times 1\text{mm}^2$ or $3 \times 1.5\text{mm}^2$ depending on the power of the heating cable used.

Options:

- Custom OEM versions
- OEM versions with only one dimension of silicone sleeve.
- Other style of plug (UK, Japan, Australia).
- Other type of cable insulation (Rubber, Rubber + PVC).
- Cable and plug without earth conductor.

Main part numbers

Plug	Cable gauge	Cord length	Part number with silicone boots K1	Part number with silicone boots K2	Part number with silicone boots K3	Part number with silicone boots K4
Europe (CEE 7/7, 16A)	$3 \times 1\text{mm}^2$	2m	6YTDKBBPE2001061	6YTDKBBPE2001062	6YTDKBBPE2001063	6YTDKBBPE2001064
Europe (CEE 7/7, 16A)	$3 \times 1.5\text{mm}^2$	2m	6YTDKBAPE2001061	6YTDKBAPE2001062	6YTDKBAPE2001063	6YTDKBAPE2001064
Europe (CEE 7/7, 16A)	$3 \times 1\text{mm}^2$	3m	6YTDKBBPE3001062	6YTDKBBPE3001062	6YTDKBBPE3001062	6YTDKBBPE3001062
Europe (CEE 7/7, 16A)	$3 \times 1.5\text{mm}^2$	3m	6YTDKBAPE3001061	6YTDKBAPE3001062	6YTDKBAPE3001063	6YTDKBAPE3001064
USA, Canada (NEMA 5-15, 3 Pin - 15 Amp)	$3 \times 1\text{mm}^2$	2m	6YTDKBBPU2001061	6YTDKBBPU2001062	6YTDKBBPU2001063	6YTDKBBPU2001064

Overmolded cord with built in anti-freeze thermostat. For use on oblong **parallel type** heating cables, **self-regulating or constant power**. Connection by crimping or soldering.
Insulation by silicone boot with RTV filling



Because of permanent improvement of our products, drawings, descriptions, features used on these data sheets are for guidance only and can be modified without prior advice

Plug	Cable gauge	Cord length	Part number with silicone boots K1	Part number with silicone boots K2	Part number with silicone boots K3	Part number with silicone boots K4
USA, Canada (NEMA 5-15, 3 Pin - 15 Amp)	3 × 1.5mm ²	2m	6YTDBAPU2001061	6YTDBAPU2001062	6YTDBAPU2001063	6YTDBAPU2001064
USA, Canada (NEMA 5-15, 3 Pin - 15 Amp)	3 × 1mm ²	3m	6YTDBBPU3001061	6YTDBBPU3001062	6YTDBBPU3001063	6YTDBBPU3001064
USA, Canada (NEMA 5-15, 3 Pin - 15 Amp)	3 × 1.5mm ²	3m	6YTDBAPU3001061	6YTDBAPU3001062	6YTDBAPU3001063	6YTDBAPU3001064

Silicone boots (Part numbers are for boots spare parts alone)

For heating cables from 9 × 5 to 9.5 × 6mm	Part number 6YTNK1	For heating cables from 8.7 × 3.5 to 11 × 3.5mm	Part number 6YTNK2
For heating cables from 11.5 × 4.5 to 13 × 6mm	Part number 6YTNK3	For heating cables from 14 × 8.7 to 14.2 × 9.2mm	Part number 6YTNK4

Heating cable wiring dimensions



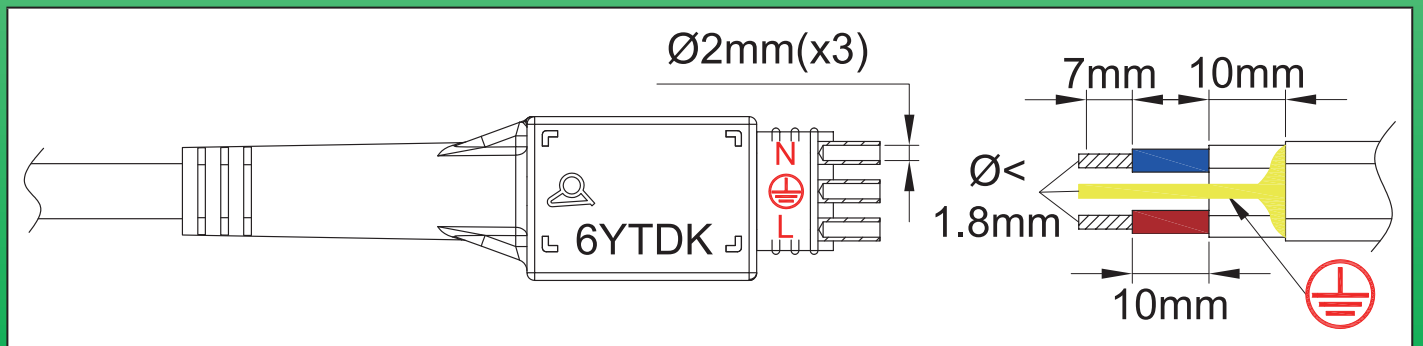



(See the technical introduction for the cable end stripping operations, which are different depending of the model of the cable)



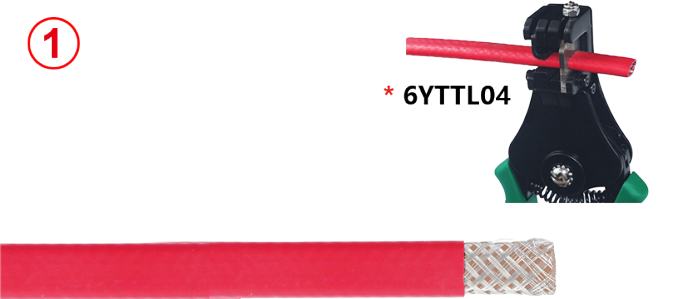

Assembly steps of the thermostatic cord with self-regulating cable

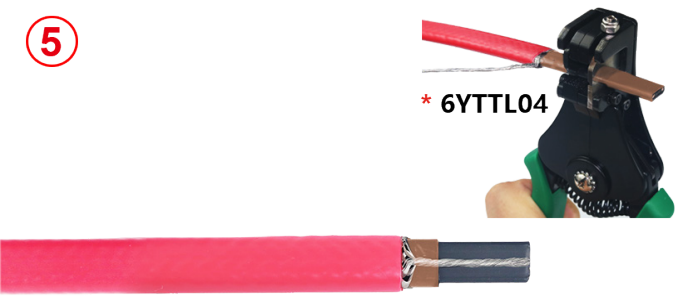
(See the technical introduction for assembly on constant power cables)

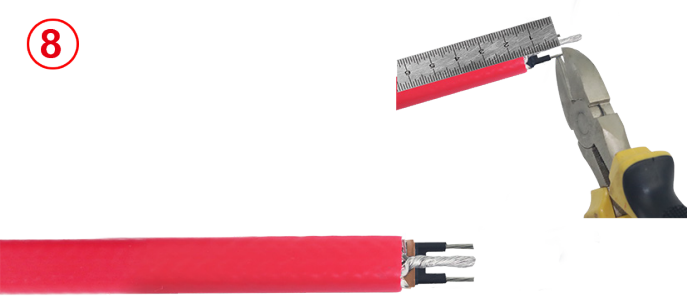
<p>①</p>  <p>* 6YTTL04</p>	<p>②</p> 
<p>1: Strip the outer jacket of the heating cable to the required length</p>	<p>2: Unweave the braid on all this length with a tool with round edges or a screw driver. (For more details about this step #2, read the technical introduction).</p>
<p>③</p> 	<p>④</p> 
<p>3: Twist the braid to make a round wire</p>	<p>4: Check that ground conductor diameter is smaller than 1.8mm. If more than this value, trim some small wires.</p>
<p>⑤</p>  <p>* 6YTTL04</p>	<p>⑥</p>  <p>* 6YTTL04</p>
<p>5: Remove the electric insulation sleeve on the requested length.</p>	<p>6: Cut and remove the heating section between the two bus wires on the requested length.</p>
<p>⑦</p>  <p>* 6YTTL04</p>	<p>⑧</p> 
<p>7: Strip off the semiconductor plastic remaining on the bus wire ends to the requested length.</p>	<p>8: Cut the conductors and the earth wire of the heating cable to the same length</p>

* These exclusive tools are available in accessories section

Overmolded cord with built in anti-freeze thermostat. For use on oblong **parallel type** heating cables, **self-regulating or constant power**. Connection by crimping or soldering.
Insulation by silicone boot with RTV filling



Because of permanent improvement of our products, drawings, descriptions, features used on these data sheets are for guidance only and can be modified without prior advice

<p>9: Slide a silicone boot with matching dimensions on the heating cable.</p>	<p>10: Insert wires inside the tubular terminals, and crimp or tin solder them.</p>
<p>11: Drop a few RTV silicone on the thermostat body ribs.</p>	<p>12: Slide the silicone boot on the thermostat body ribs</p>
<p>13: Put on horizontal position and fill with RTV silicone by the funnel. Let cure during 24 hours. Don't energize during the curing time.</p>	<p>14: After curing, cut the filling funnel.</p>

Silicone sleeves for connection of **heating cables and power supply cords on thermostats** (field or workshop assembly). Installation on the free end of the heating cable, for oblong heating cables, limited to **series models with two side by side bus wires**. Connection by soldering. Sealing of the connection by silicone sleeve + RTV.



Material	Pull test nominal strength	Cables types	Assembly		Type
Silicone	>12DaN*	Oblongs	Silicone RTV filling		6YTNL

* Variable value from 12 to 21DaN depending on the models and sections of cables. See the test results in the technical introduction

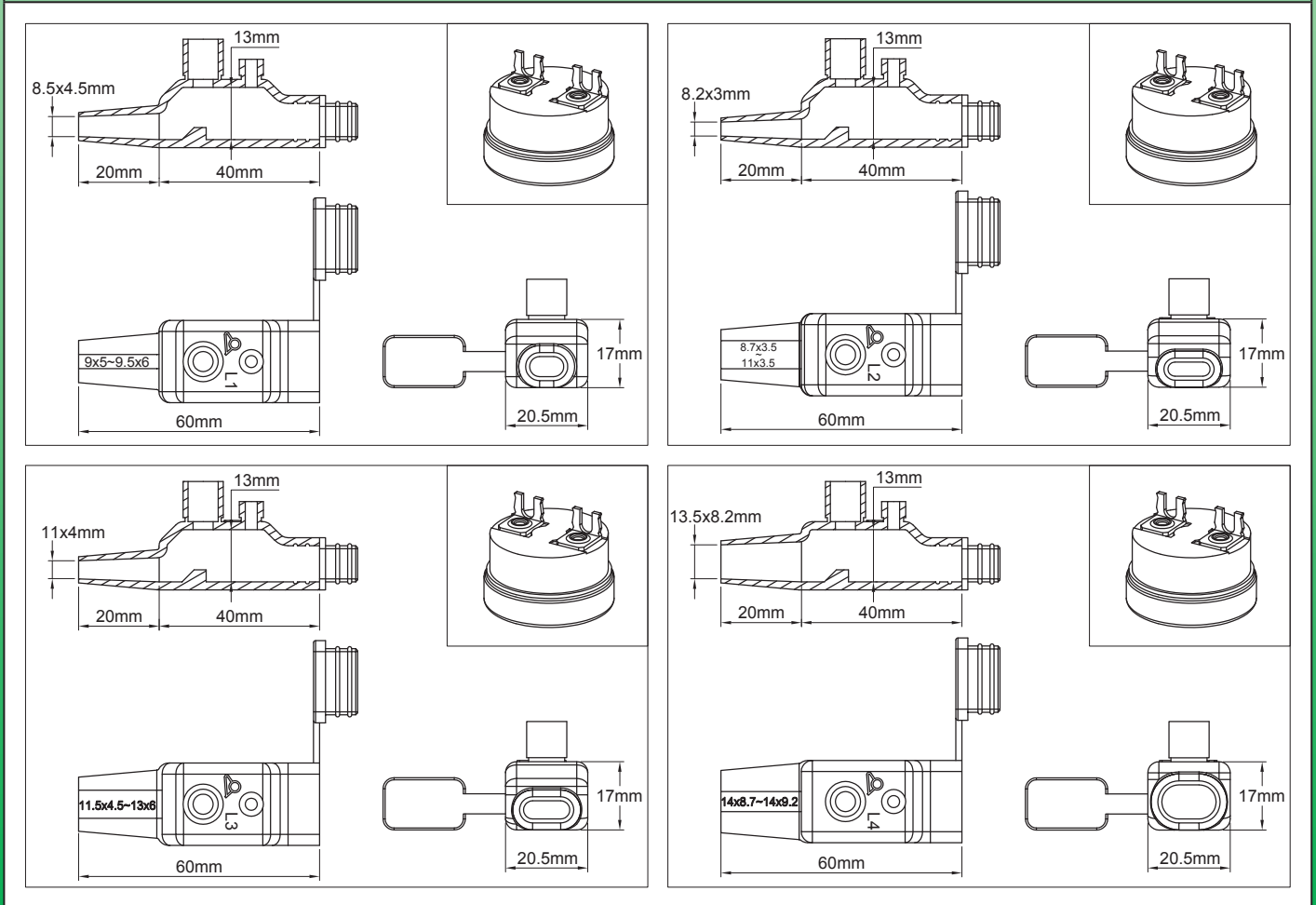
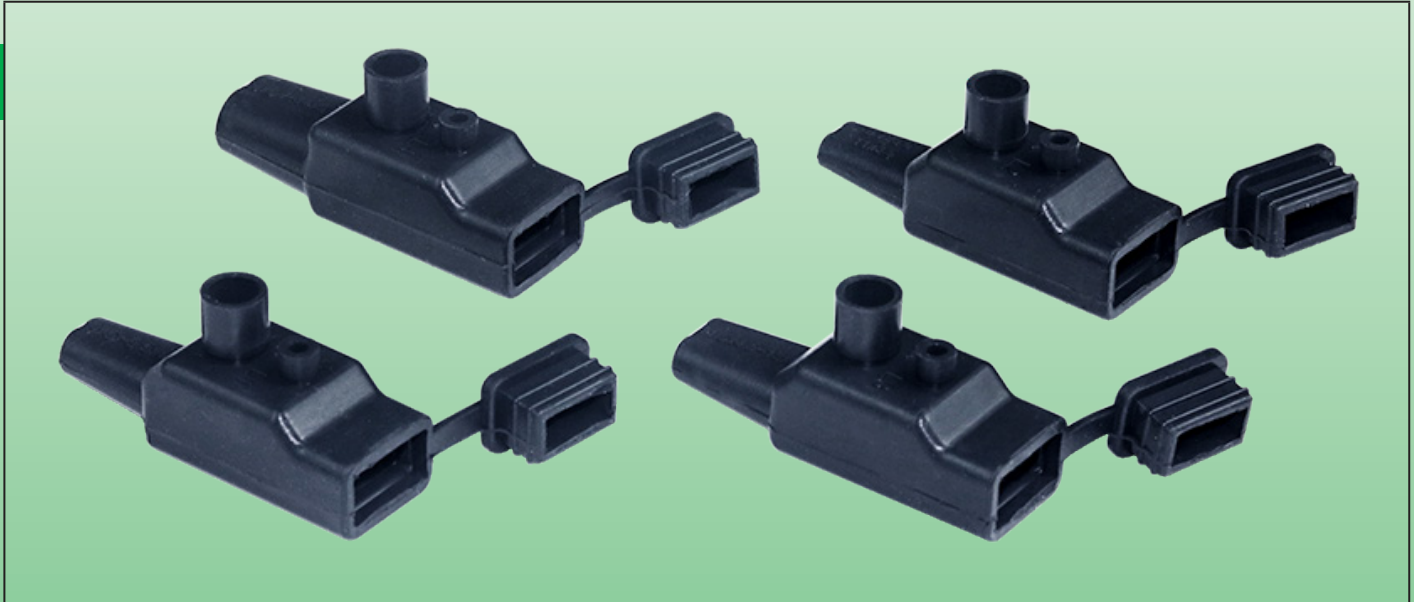

Because of permanent improvement of our products, drawings, descriptions, features used on these data sheets are for guidance only and can be modified without prior advice

Silicone sleeves for connection of **heating cables and power supply cords on thermostats** (field or workshop assembly). Installation on the free end of the heating cable, for oblong heating cables, limited to **series models with two side by side bus wires**. Connection by soldering. Sealing of the connection by silicone sleeve + RTV.



Applications

These silicone caps allow to install by an **economical and waterproof** way, in the workshop or even on the field, a **fixed temperature disc thermostat at the free end of a series heating cable with two-conductors side by side**. At the same time, they close and seal this end. They eliminate the use of heat shrink sleeves. These caps are more particularly intended for domestic applications. They cannot be used on parallel cables of self-regulating or of constant power types.

Main features

Boot material: UL 94-VO, black or orange silicone (other colors on request). Temperature resistance 220°C.

Boot dimensions: The elasticity of the silicone, higher than 200%, allows it to fit the exact shape of the cable. We recommend selecting a cap that is slightly smaller than the cable section to avoid the resin tearing during the filling.

Thermostat: It is possible to deliver this boot with a thermostat for soldering on the wires of the heating cable. Open temperature $10 \pm 3^\circ\text{C}$, close temperature $4 \pm 3^\circ\text{C}$, electrical rating 16A 250V. Other temperatures on request.

Options: We can produce any special dimensions or design with MOQ of 1000 pieces.

Main part numbers (Black silicone*)

Reference of the boot alone	Hole dimension	Minimum and maximum** cable dimensions	Boot identification
6YTNL01N09800045	8.5 × 4.5mm	9 × 5mm ~ 9.5 × 6mm	L1
6YTNL02N08620032	8.2 × 3mm	8.7 × 3.5mm ~ 11 × 3.5mm	L2
6YTNL03N13006075	11 × 4mm	11.5 × 4.5mm ~ 13 × 6mm	L3
6YTNL04N10005546	13.5 × 8.2mm	14 × 8.7mm ~ 14 × 9.2mm	L4

* Orange colour, replace the 8th character N by M.

** The maximum dimensions are given for information only and can be increased within the elastic limit of the silicone.

Thermostat part number (To be ordered separately).

	Open temperature	Close temperature	Reference
	$10 \pm 3^\circ\text{C}$	$4 \pm 3^\circ\text{C}$	4911EJ01006CUSV0



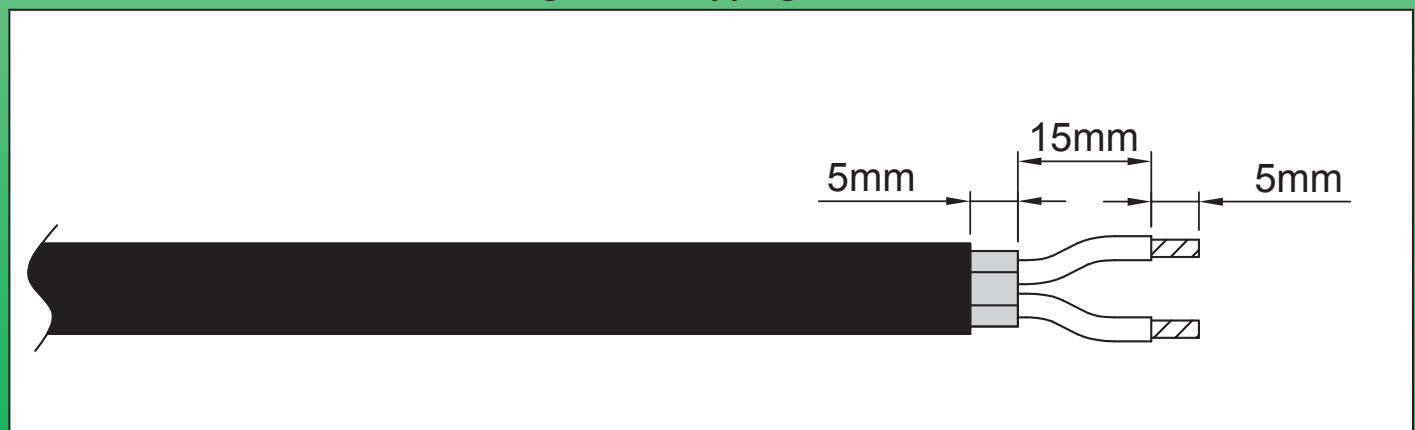







Heating wires stripping dimensions



Silicone sleeves for connection of **heating cables and power supply cords on thermostats** (field or workshop assembly). Installation on the free end of the heating cable, for oblong heating cables, limited to **series models with two side by side bus wires**. Connection by soldering. Sealing of the connection by silicone sleeve + RTV.

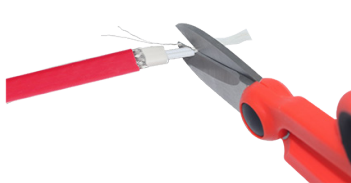

Methods of incorporating a fixed setting disc thermostat on a serial type heating cable with 2 wires side by side.

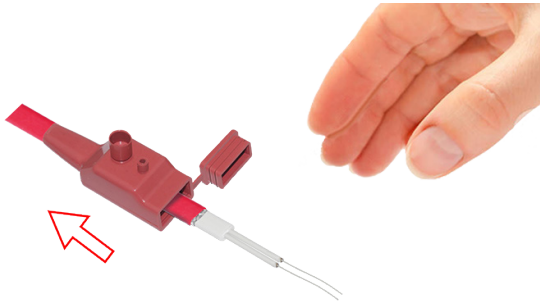
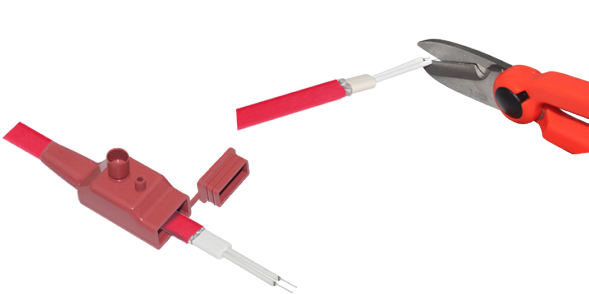
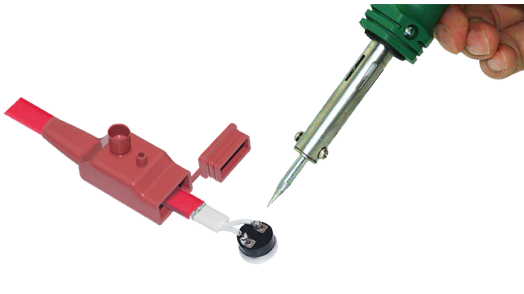
<p>①</p>  <p>* 6YTTL04</p> 	<p>②</p>  
<p>1: If it exists, remove the outer sheath over a sufficient length with a tool of appropriate size.</p>	<p>2: If it exists, cut the metal braid at the same place than the outer sheathing.</p>
<p>③</p>  <p>* 6YTTL04</p> 	<p>④</p>  <p>* 6YTTL04</p> 
<p>3: Strip the heating part insulation with a wire stripper appropriate to its diameter.</p>	<p>4: Strip the two conductors with a wire stripper of appropriate diameter.</p>
<p>⑤</p>  	<p>⑥</p> 
<p>5: Untwist the heating wires and cut the fiberglass or aramid core. (Skip this step for straight multi-strand heating cables without a textile core).</p>	<p>6: Slide the silicone boot onto the heating cable.</p>
<p>⑦</p> 	<p>⑧</p> 
<p>7: Cut the conductors to the length required for soldering on the thermostat terminals.</p>	<p>8: Tin solder the heating conductors on the thermostat terminals.</p>

* These exclusive tools are available in accessories section

Because of permanent improvement of our products, drawings, descriptions, features used on these data sheets are for guidance only and can be modified without prior advice

Silicone sleeves for connection of **heating cables and power supply cords on thermostats** (field or workshop assembly). Installation on the free end of the heating cable, for oblong heating cables, limited to **series models with two side by side bus wires**. Connection by soldering. Sealing of the connection by silicone sleeve + RTV.

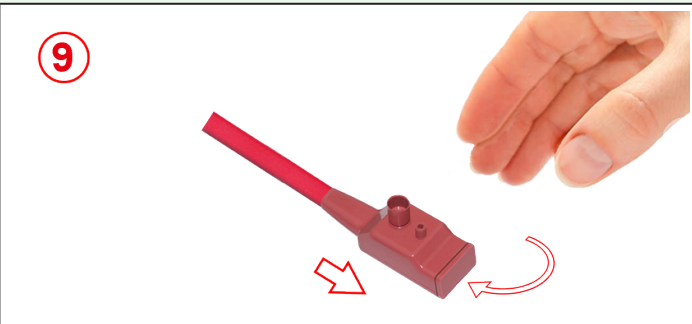
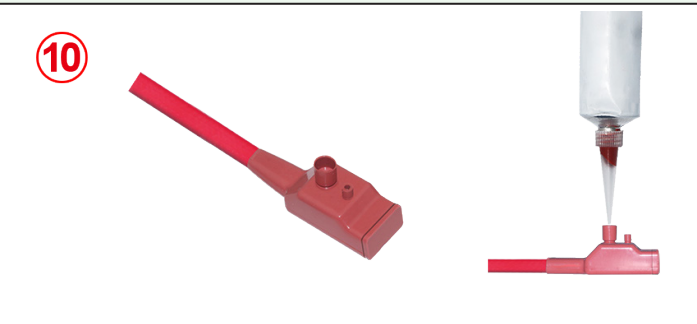
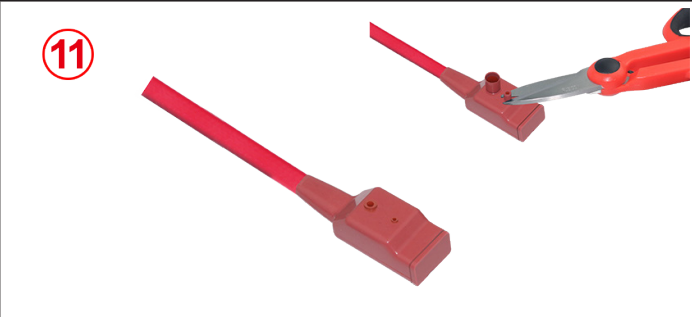

Because of permanent improvement of our products, drawings, descriptions, features used on these data sheets are for guidance only and can be modified without prior advice

	
<p>9: Slide the silicone boot on the thermostat housing. Take care to have the temperature sensing metal part facing downside. Then close the lid.</p>	<p>10: Place the assembly on a horizontal surface and fill with liquid RTV silicone through the filling funnel until this silicone begins to rise in the small degassing opening. Leave to cure for approximately 24 hours.</p>
	
<p>11: When the silicone is hardened, cut the filling and degassing funnels.</p>	

Silicone sleeves for connection of **heating cable on power supply wires** (field or workshop assembly). Filling with room temperature vulcanizing silicone resin (RTV)



Material	Pull test nominal strength	Heating cables types	Assembly		Type
Silicone	> 8DaN*	Oblongs	Silicone RTV filling		

* Variable value from 8 to 18DaN depending on the models and sections of cables. See the test results in the technical introduction

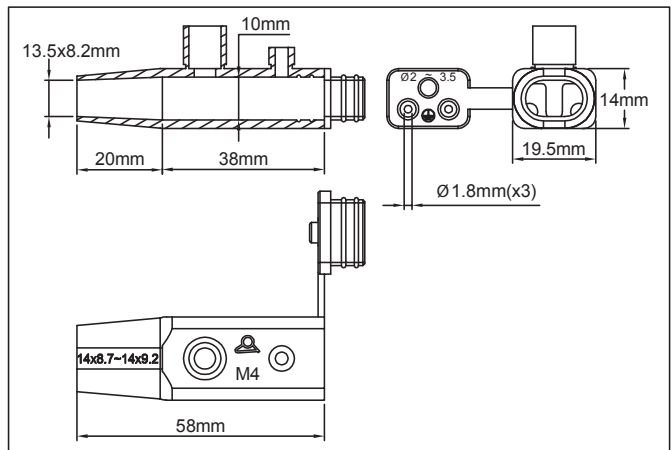
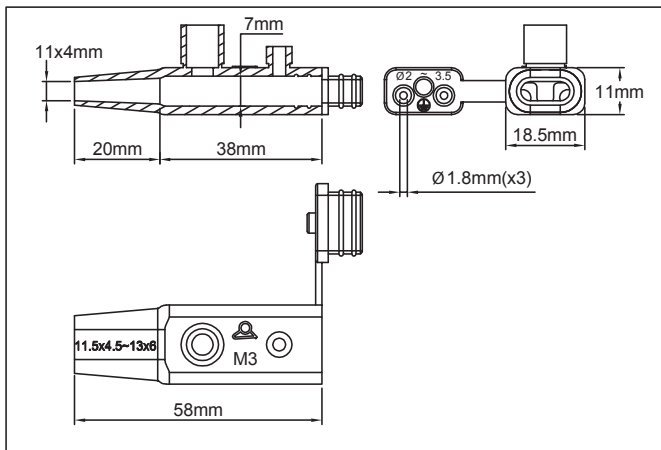
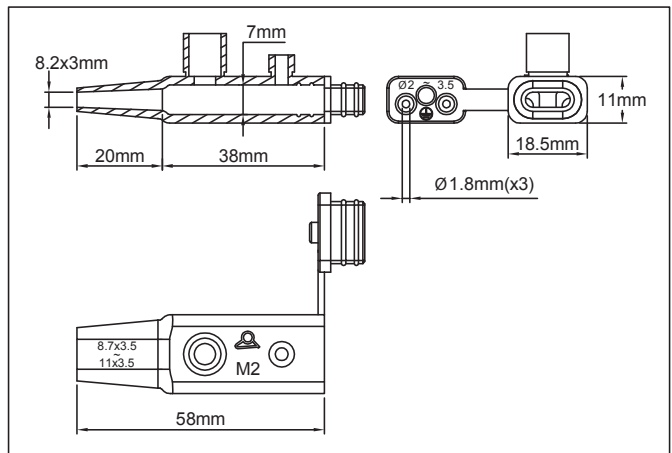
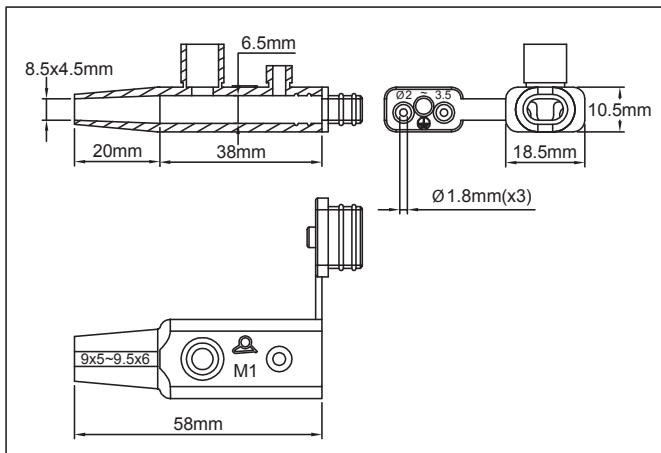
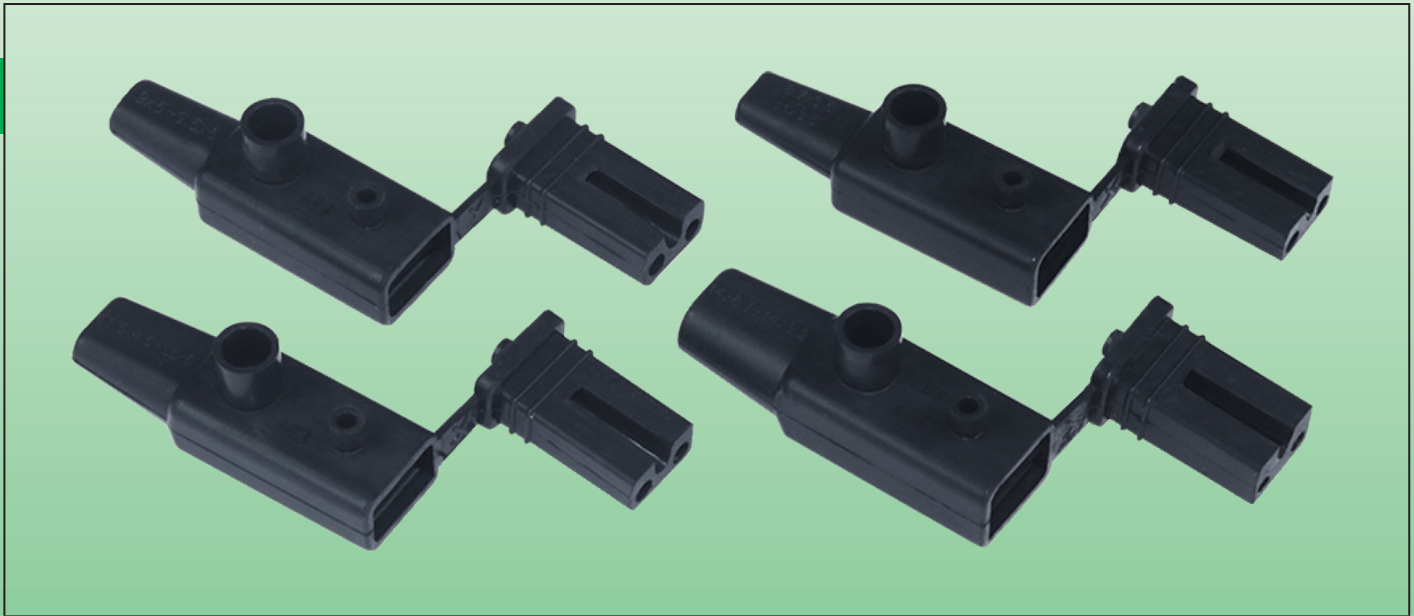

Because of permanent improvement of our products, drawings, descriptions, features used on these data sheets are for guidance only and can be modified without prior advice



Applications

These silicone caps allow to install by an **economical, waterproof and temperature resistant** way, in the workshop or even on the field, of **power supply wires (said "cold wires") on oblong heating cables**. They eliminate the use of heat shrink sleeves. These caps are more particularly intended for domestic applications.

Main features

Boot material: UL 94-VO, black or orange silicone (other colors on request). Temperature resistance 220°C.

Boot dimensions: The elasticity of the silicone, higher than 200%, allows it to fit the exact shape of the cable. We recommend selecting a cap that is slightly smaller than the cable section to avoid the resin tearing during the filling.

Options: We can produce any special dimensions or design with MOQ of 1000 pieces.

Main part numbers (Black silicone*)

Reference	Hole dimension	Minimum and maximum** cable dimensions	Boot identification
6YTNM01N08504545	8.5 × 4.5mm	9 × 5mm ~ 9.5 × 6mm	M1
6YTNM02N08203032	8.2 × 3mm	8.7 × 3.5mm ~ 11 × 3.5mm	M2
6YTNM03N11004075	11 × 4mm	11.5 × 4.5mm ~ 13 × 6mm	M3
6YTNM04N13508246	13,5 × 8.2mm	14 × 8.7mm ~ 14 × 9.2mm	M4

* Orange colour, replace the 8th character N by M.

** The maximum dimensions are given for information only and can be increased within the elastic limit of the silicone.

Heating wires stripping dimensions

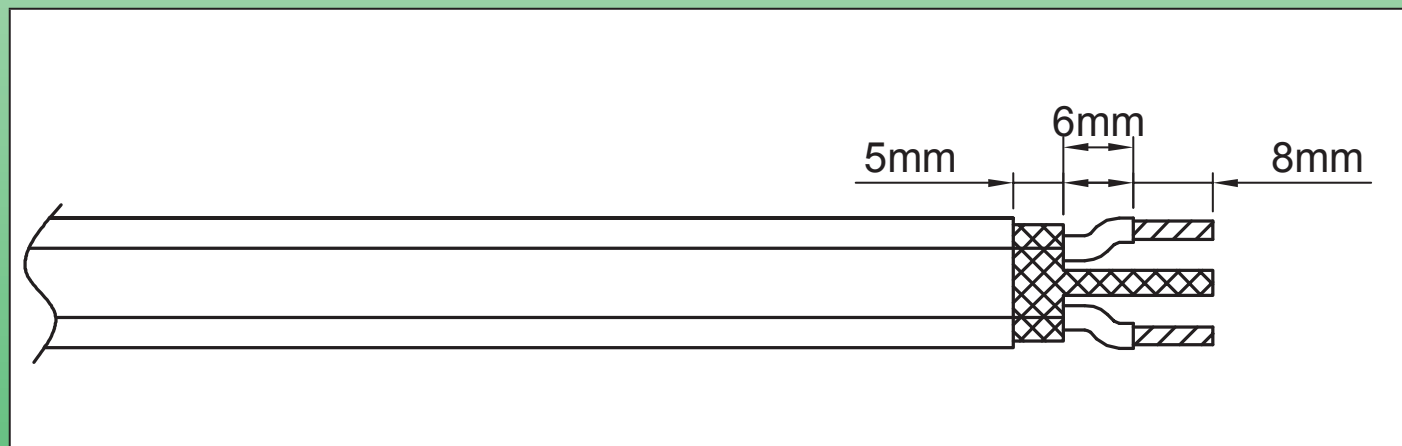

Connection steps of power supply wires ("cold wires") on a self-regulating heating cable. (Methods for other types of heating wires are described in the technical introduction).

<p>①</p> <p>* 6YTTL04</p>	<p>②</p>
<p>1: Remove the outer sheath over a sufficient length with a tool of appropriate size.</p>	<p>2: Un-weave the braid with a rounded pin or a small screw driver</p>

* These exclusive tools are available in accessories section

Silicone sleeves for connection of **heating cable on power supply wires** (field or workshop assembly). Filling with room temperature vulcanizing silicone resin (RTV)



Because of permanent improvement of our products, drawings, descriptions, features used on these data sheets are for guidance only and can be modified without prior advice

<p>3</p>	<p>4</p>
<p>3: Twist the braid into a round wire</p>	<p>4: Strip the heating part insulation with a wire stripper appropriate to its diameter.</p>
<p>5</p>	<p>6</p>
<p>5: Cut the heating semiconductor plastic between the 2 bus wires on the requested length with an appropriate tool.</p>	<p>6: Strip the two conductors with a wire stripper of appropriate diameter.</p>
<p>7</p>	<p>8</p>
<p>7: Cut the conductors to the length required for crimping or soldering them together.</p>	<p>8: If the wiring has a ground conductor, cut the small silicone dome closing its output hole.</p>
<p>9</p>	<p>10</p>
<p>9: Slide the silicone boot around the cable and slide the cold wires inside the silicone boot lid.</p>	<p>10: Crimp the wires inside the tubular terminals. (This step can also be replaced by tin soldering).</p>

* These exclusive tools are available in accessories section

Silicone sleeves for connection of heating cable on power supply wires (field or workshop assembly). Filling with room temperature vulcanizing silicone resin (RTV)

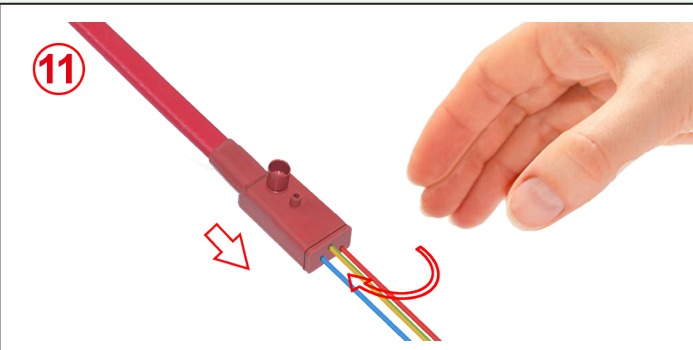
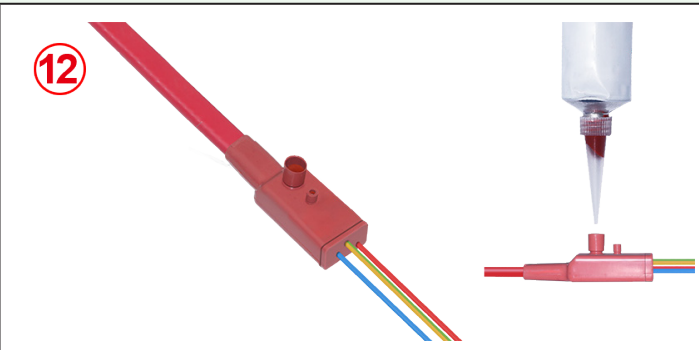
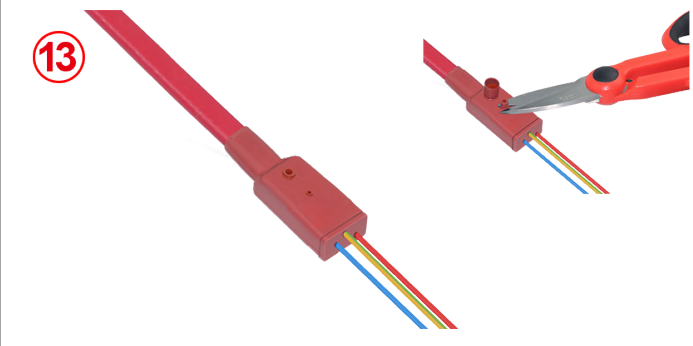

Because of permanent improvement of our products, drawings, descriptions, features used on these data sheets are for guidance only and can be modified without prior advice

	
<p>11: Slide the silicone boot on the connected wires. Then close the lid.</p>	<p>12: Place the assembly on a horizontal surface and fill with liquid RTV silicone through the filling funnel until this silicone begins to rise in the small degassing hole. Leave to cure for approximately 24 hours.</p>
	
<p>13: When the silicone is hardened, cut the filling and degassing funnels.</p>	

* These exclusive tools are available in accessories section

Termination caps for **closing the free end** of round and flat heating cables (**workshop or field use**).
Can be mounted dry, or filled with room temperature vulcanizing silicone resin (RTV)



Because of permanent improvement of our products, drawings, descriptions, features used on these data sheets are for guidance only and can be modified without prior advice

Material	Pull test nominal strength	Cables types	Assembly		Type
Silicone	>5DaN*	Round or oblong	Glued		

* Variable value from 5 to 46 DaN depending on the models and sections of cables. See the test results in the technical introduction

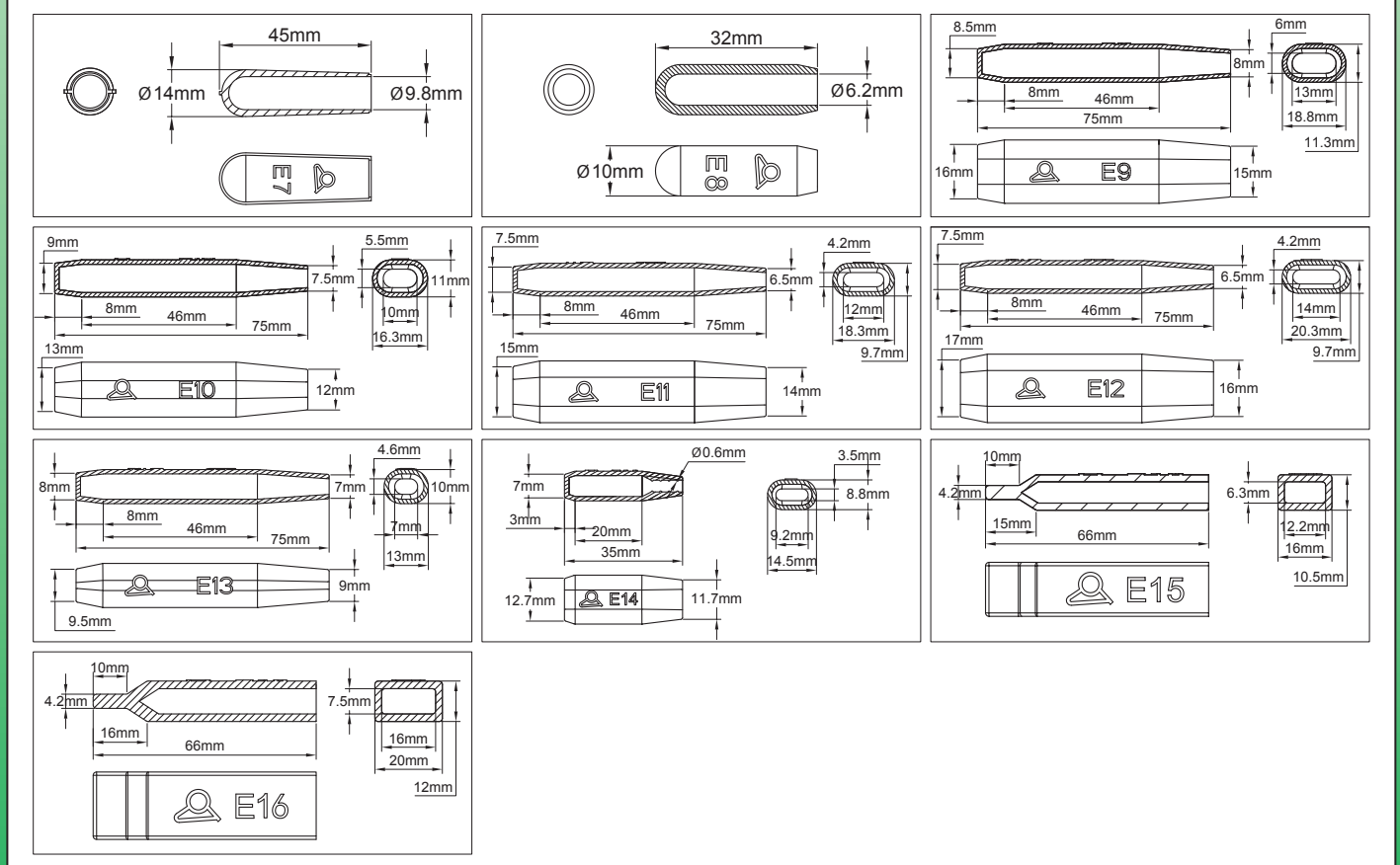
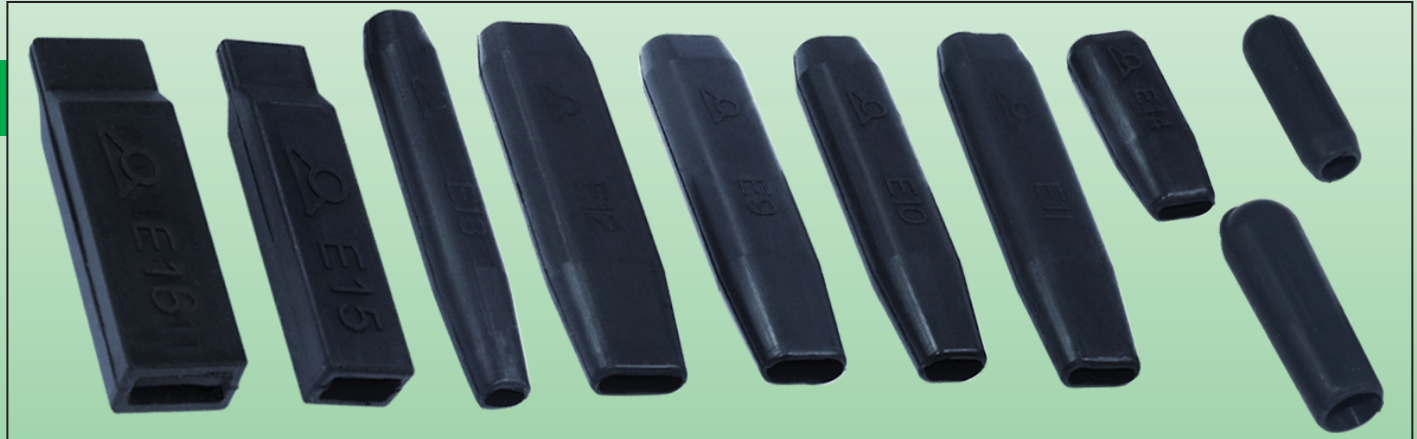

Applications

Sealing the free end of heating cables, in particular constant power cables or self-regulating cables, is simplified by these **very economical cable end boots**, which eliminate the use of heat-shrink sleeves. These boots are intended for domestic applications

Main features

Boot material: UL 94-VO, black silicone (other colors on request). Temperature resistance 220°C.

Boot dimensions: The elasticity of the silicone, higher than 200%, allows it to fit the exact shape of the cable. We

**Termination caps for closing the free end of round and flat heating cables (workshop or field use).
Can be mounted dry, or filled with room temperature vulcanizing silicone resin (RTV)**



Because of permanent improvement of our products, drawings, descriptions, features used on these data sheets are for guidance only and can be modified without prior advice

recommend selecting a cap that is 10 to 20% smaller than the cable section. We also recommend to stick it with RTV silicone resin to avoid its accidental tearing,

Options:

- These boots can be made with partial filling in silicone gel.
- We can produce any special dimensions or design with MOQ of 1000 pieces.

Main part numbers (Black silicone, without silicone gel filling)**

Reference	Hole dimension	Minimum cable dimensions*	Boot identification
6YTNE07N09800045	Dia. 9.8mm	Dia. 11.5mm	E7
6YTNE08N08620032	Dia. 6.2mm	Dia. 7.5mm	E8
6YTNE09N13006075	13 × 6mm	15.5 × 7.2mm	E9
6YTNE10N10005546	10 × 5.5mm	12 × 6.6mm	E10
6YTNE11N12004275	12 × 4.2mm	14.4 × 5mm	E11
6YTNE12N14004275	14 × 4.2mm	16.8 × 5mm	E12
6YTNE13N06804675	6.8 × 4.6mm	8.2 × 5.5mm	E13
6YTNE14N09203575	9.2 × 3.5mm	11 × 4.2mm	E14
6YTNE15N12206366	12.2 × 6.3mm	14.5 × 7.5mm	E15
6YTNE16N16007566	16 × 7.5mm	19 × 9mm	E16

* Dimensions for glued boot, allowing to comply with the minimum pull strength.

** Orange colour, replace the 8th character N by M

Pressure screw-clamping IP67 waterproof PA66 termination caps (End seals) for closing the free end of oblong or round heating cables.



Materials	Minimum tear strength	Heating cables types	Assembly	 ATEX IECEX CCCEX	Type
PA66, stainless steel, Silicone	>25 DaN	Oblongs ou ronds	Locked on the cable		6YTEW



Before assembly on cable



After cable insertion tightening and assembly on pipe

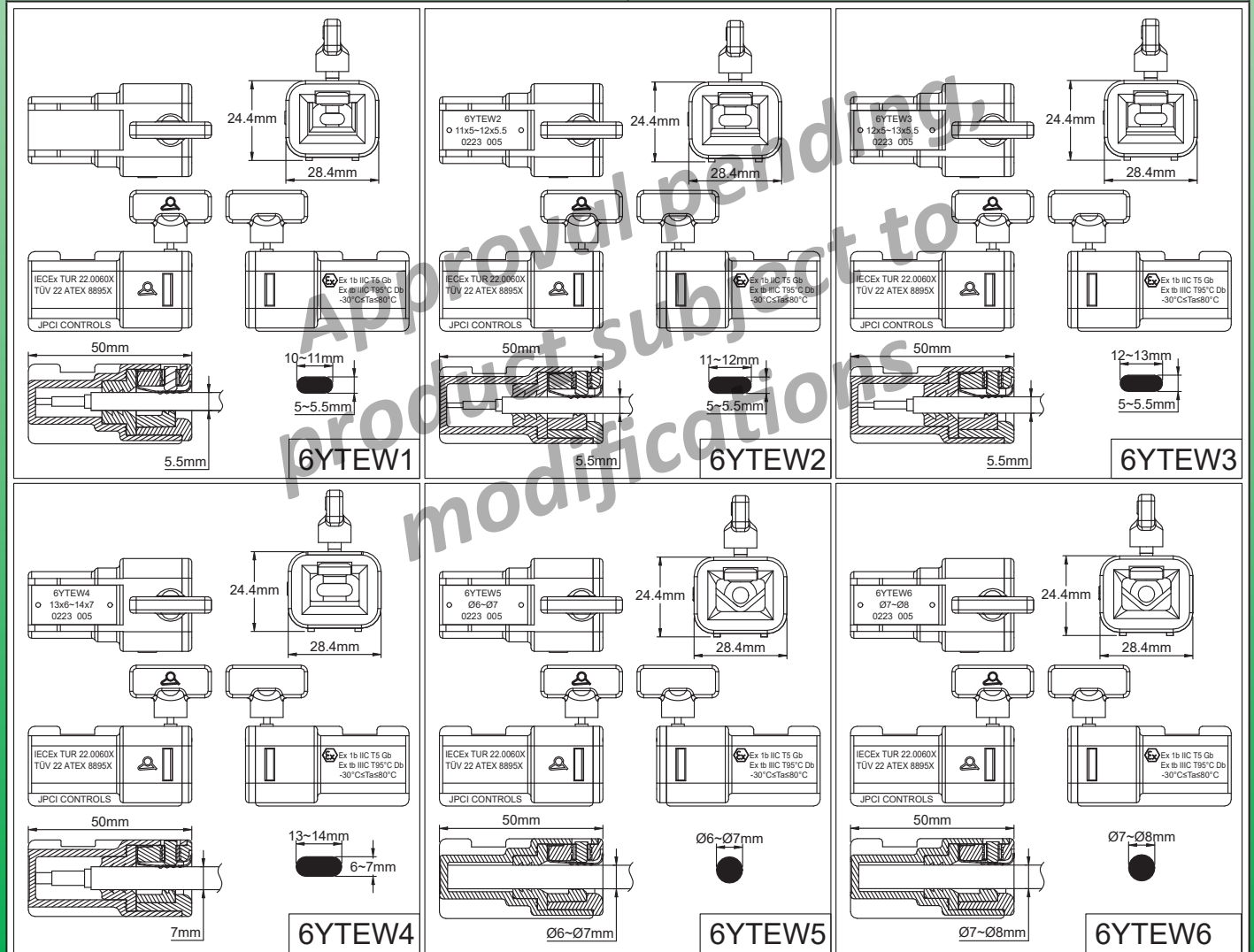

Pressure screw-clamping IP67 waterproof PA66 termination caps (End seals) for closing the free end of oblong or round heating cables.



Applications

These cable ends are used to close quickly and without the need for gluing or filling with resin or the terminations of flexible self-regulating or constant power heating cables. **They are instantly tightened and blocked on the cables without special tool or equipment.**

Their tightening on the cable is made by a butterfly screw which will break at a preset torque. Unscrewing is then impossible. Once installed, they provide an IP67 seal at the end of the cable.

Their range of dimensions allows them to be used on most existing heat tracing heating cables in industrial or explosive environments. Their tear resistance is guaranteed regardless of the material of the outer sheath of the heating cable (Polyolefins, PVC, fluoroelastomers, FEP a.s.o.)

Main features

Body material: UV resistant PA66. Internal seal is in silicone).

The wings of the body allow to move it away from the piping and improve its cooling. They also allow stable clamping on the piping by a cable tie. A notch prevents the cable tie from slipping

Maximum temperature resistance: + 80°C. (For higher temperatures, see silicone cable end boots 6YTNJ with silicone resin filling).

Resistance at minimum temperature: - 30°C (For lower temperatures, see the silicone cable end boots 6YTNJ with silicone resin filling).

Tear resistance: Greater than 25 DaN for all models.

This value is equal to or greater than required by standard EN60079-0 for cable terminations in explosive environments and higher than required by standard IEC 62395-1 for heating cables in industrial environment.

Options: Special dimensions possible, with minimum order of 1000 pieces.

Other models: In some cases, especially for constant power cables with a bus wires spacing of less than 5mm, it is necessary to use the version with silicone gel filling.

Warning: These products cannot be used on cables with an external metallic braid not covered by an outer jacket because in this case the waterproofing cannot be achieved. Then use terminations with silicone resin filling. (See types 6YTNJ at the end of this catalogue).

Classification for hazardous areas:

Gaz: II 2G Ex eb IIC T5 Gb

Dust: II 2D Ex tb IIIC T95°C Db

Certificates:

ATEX: TÜV 22 ATEX 8895X

IECEX: IECEX TUR 22.0060X

Main part numbers

Part number*	Minimum cable size	Maximum cable size	Identification
6YTEW16S0F5010	10 × 5mm	11 × 5.5mm	W1
6YTEW26S0F50110	11 × 5mm	12 × 5,5mm	W2
6YTEW36S0F50120	12 × 5mm	13 × 5,5mm	W3
6YTEW46S0F60130	13 × 6mm	14 × 7mm	W4
6YTEW56S0R60000	Dia. 6mm	Dia. 7mm	W5
6YTEW66S0R70000	Dia. 7mm	Dia. 8mm	W6

* Types with silicone gel filling: replace S0 by SG in the reference

Pressure screw-clamping IP67 waterproof PA66 termination caps (End seals) for closing the free end of oblong or round heating cables.



Heating wires stripping dimensions.

(See the technical introduction for explanation of these dimensions that can be reduced in some cases)

Self-regulating cable with jacketed braid and with clearance between bus wires equal or bigger than 5mm.	Self-regulating cable with jacketed braid and distance between bus wires lower than 5mm.	Constant power cable with jacketed braid, clearance between bus wires equal or bigger than 5mm	Constant power cable with jacketed braid, clearance between bus wires lower than 5mm
<p>There must be a minimum of 10mm distance between the semiconductor core and the metal braid.</p>	<p>One conductor wire must be cut to maintain a 5mm minimum clearance between the 2 bus wires. There must be a minimum of 10mm distance between the semiconductor core and the metal braid.</p>	<p>There must be a minimum of 10mm distance between the bus wires and the metal braid. The small heating wire must not protrude from its insulating jacket</p>	<p>One conductor wire must be cut to maintain a 5mm minimum clearance between the 2 bus wires. There must be a minimum of 10mm distance between the bus wire and the metal braid. The small heating wire must be cut to not protrude from its insulating jacket. It is mandatory to use the termination with silicone gel filling.</p>

Installation instruction

<ul style="list-style-type: none"> - Prepare the end of the cable according to the dimensions given in the table above. - Check that its dimensions are compatible with those written on the selected termination cap. - Check that the calculated or measured operating temperature does not exceed the limit value of 120° C at the termination cap. 	<p>- Insert the cable into the termination cap, push it strongly until it comes to a stop. (It must penetrate 48mm)</p>	<p>- Tighten the wing screw until it breaks flush with the termination cap. - This screw is calibrated to break when the torque necessary for the pulling force of the cable to comply with standards is reached. <u>The whole assembly is no longer removable.</u> (When the application requests subsequent disassembly, it is possible to replace, before installation, the wing screw with a simple M4×8mm grub screw, with hexagonal hollow head. The recommended tightening torque is then 1.3 Nm)</p>	<p>- Fix the cable termination cap on the piping or on the surface, using a nylon tie or a metal clamp and placing it on the notch provided, to prevent it from slipping. - Tightening should be moderate so as not to damage the termination cap. If the pipe temperature can rise temperatures up to 80°C, keep the termination away of the tube</p>
---	---	--	--

Because of permanent improvement of our products, drawings, descriptions, features used on these data sheets are for guidance only and can be modified without prior advice

Silicone end seals, for **termination of the free end** for all types of flexible heating cables. They include a filling system with silicone resin vulcanizing at room temperature (RTV), usable without special tools **on site or in the workshop**.



Because of permanent improvement of our products, drawings, descriptions, features used on these data sheets are for guidance only and can be modified without prior advice

Material	Pull test nominal strength	Heating cables types	Assembly		Type
Silicone	>8 DaN*	All	Silicone RTV filling		6YTNJ

* Variable value from 8 to 36 DaN depending on the models and sections of cables. See the test results in the technical introduction

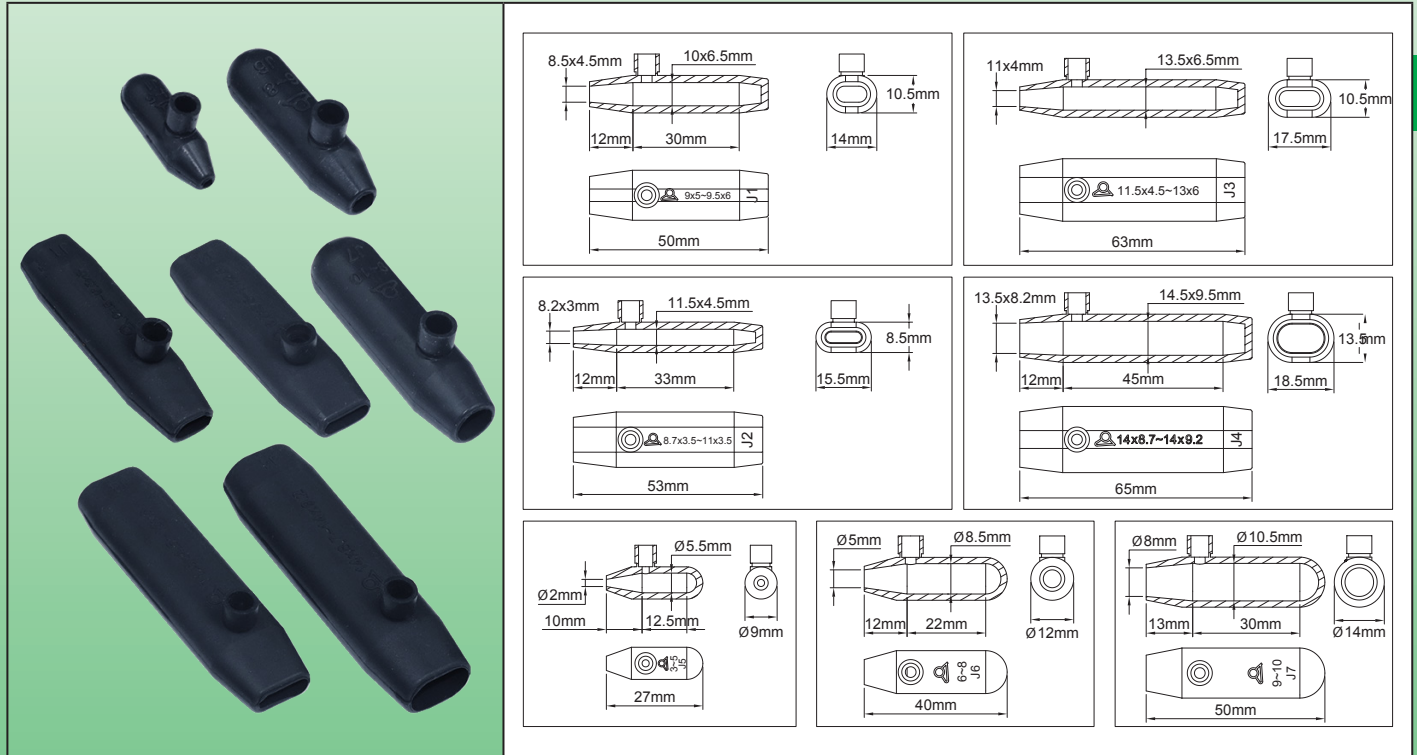

Applications

These silicone caps allow to install by an **economical, waterproof and temperature resistant** way, in the workshop or even on the field, an **end seal on heating cables**. They eliminate the use of heat shrink sleeves.

Main features

Boot material: UL 94-VO, black or orange silicone (other colors on request). Temperature resistance 220°C.

Boot dimensions: The elasticity of the silicone, higher than 200%, allows it to fit the exact shape of the cable. We recommend selecting a cap that is slightly smaller than the cable section to avoid the resin tearing during the filling.

Options: We can produce any special dimensions or design with MOQ of 1000 pieces.

Main part numbers (Black silicone*)

Reference	Hole dimension	Minimum and maximum cable dimensions**	Boot identification
6YTNJ01N08504550	8.5 × 4.5mm	9 × 5mm ~ 9.5 × 6mm	J1
6YTNJ02N08203053	8.2 × 3mm	8.7 × 3.5mm ~ 11 × 3.5mm	J2
6YTNJ03N11004063	11 × 4mm	11.5 × 4.5mm ~ 13 × 6mm	J3
6YTNJ04N13508265	13.5 × 8.2mm	14 × 8.7mm ~ 14 × 9.2mm	J4
6YTNJ05N00200027	∅ 2mm	∅ 3mm ~ ∅ 5mm	J5
6YTNJ06N00500040	∅ 5mm	∅ 6mm ~ ∅ 8mm	J6
6YTNJ07N00800050	∅ 8mm	∅ 9mm ~ ∅ 10mm	J7

* Orange colour, replace the 8th character N by M.

** The maximum dimensions are given for information only and can be increased within the elastic limit of the silicone.

Silicone end seals, for **termination of the free end** for all types of flexible heating cables. They include a filling system with silicone resin vulcanizing at room temperature (RTV), usable without special tools **on site or in the workshop**.



Heating wires stripping dimensions

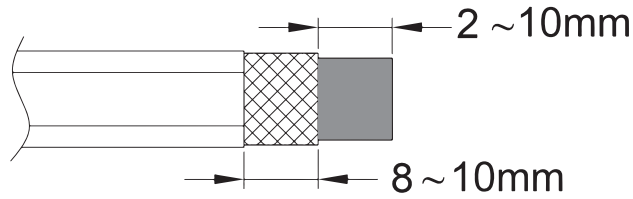

Assembly steps on a self-regulating heating cable.

(Methods for other types of heating wires are described in the technical introduction).

<p>①</p> <p>* 6YTTL04</p>	<p>②</p>
<p>1: Remove the outer sheath over a sufficient length with a tool of appropriate size.</p>	<p>2: Cut the metal braid to the length required by the drawing. It is important to keep a certain length because it provides good resistance to tearing.</p>
<p>③</p>	<p>④</p>
<p>3: Take the boot, place it vertically and fill it about halfway with room temperature curing silicone resin (RTV).</p>	<p>4: Slide slowly the silicone boot on the cable until the silicone resin level rises inside the small degassing hole</p>
<p>⑤</p>	
<p>5: Lay the assembly flat, wait about 24 hours and when the silicone is cured, cut the degassing orifice. Do not energize until the silicone resin has polymerized.</p>	

* These exclusive tools are available in accessories section

Sheathing and insulation boot for self-regulating heating cable conductors **after removal of the heating zone.**



Material	Pull test nominal strength	Heating cables types	Assembly		Type
Silicone	Poor	Self-regulating	Slided on conductors		6YTNB

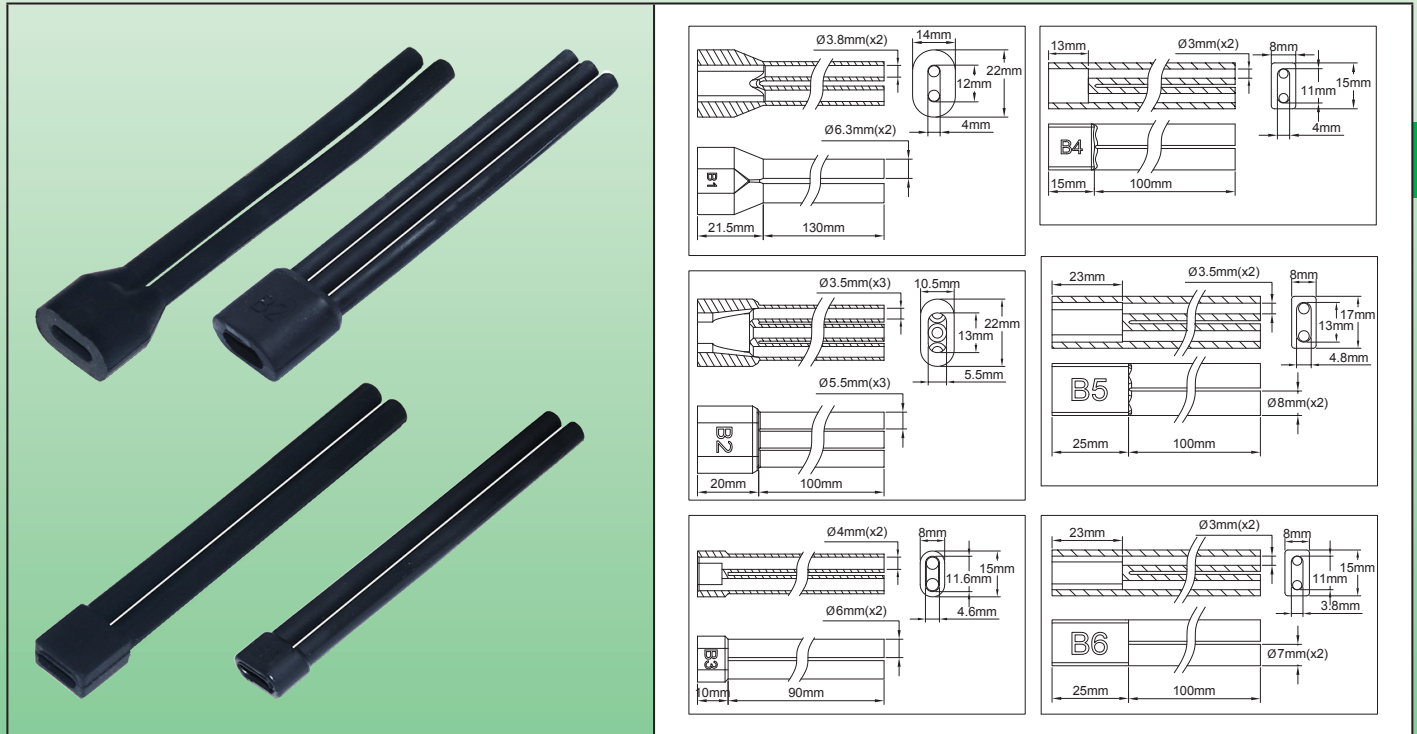

Applications

These silicone caps are used to **recreate electrical insulation** to the conductors of the self-regulating cables when the heating zone has been removed to suppress heating over a certain length. Indeed, the semiconductor plastic remaining around the wires is an electrical conductor and not an insulator.

They consist of 2 or 3 flexible tubes connected by a collector, and must be put on the bus wires. They are mainly used in the connection of heating cables on terminal blocks of electrical tracing distribution boxes, in order to avoid heating them inside.

Main features

Boot material: UL 94-VO, black or orange silicone (other colors on request). Temperature resistance 220°C.

Boot dimensions: The elasticity of the silicone, higher than 200%, allows it to fit the exact shape of the cable. We recommend choosing a boot with a hole slightly smaller than the cable section, in order to block its position. For the same purpose, it is mandatory to fill with RTV silicone resin the collector.

The chimneys of the boots must be cut to the length of the bus wires and must allow only the naked length of the conductor necessary to connect to the terminal block.

Options: We can produce any special dimensions or design with MOQ of 1000 pieces.

Main part numbers (Black silicone*)

Reference	Entry hole dimension	Quantity of tubes	Maximum sleeving length of bus wires	Boot identification
6YTNB01N120040A5	12 × 4mm	2	130mm	B1
6YTNB02N125055A2	12.5 × 5.5mm	3	100mm	B2
6YTNB03N116046A0	11.6 × 4.6mm	2	90mm	B3
6YTNB04N110040A1	11 × 4mm	2	100mm	B4

Sheathing and insulation boot for self-regulating heating cable conductors **after removal of the heating zone.**



Reference	Entry hole dimension	Quantity of tubes	Maximum sleeving length of bus wires	Boot identification
6YTNB05N130048A2	13 × 4.8mm	2	100mm	B5
6YTNB06N110038A2	11 × 3.8mm	2	100mm	B6

* Orange colour, replace the 8th character N by M.

Heating wires stripping dimensions **with cable gland crossing.**

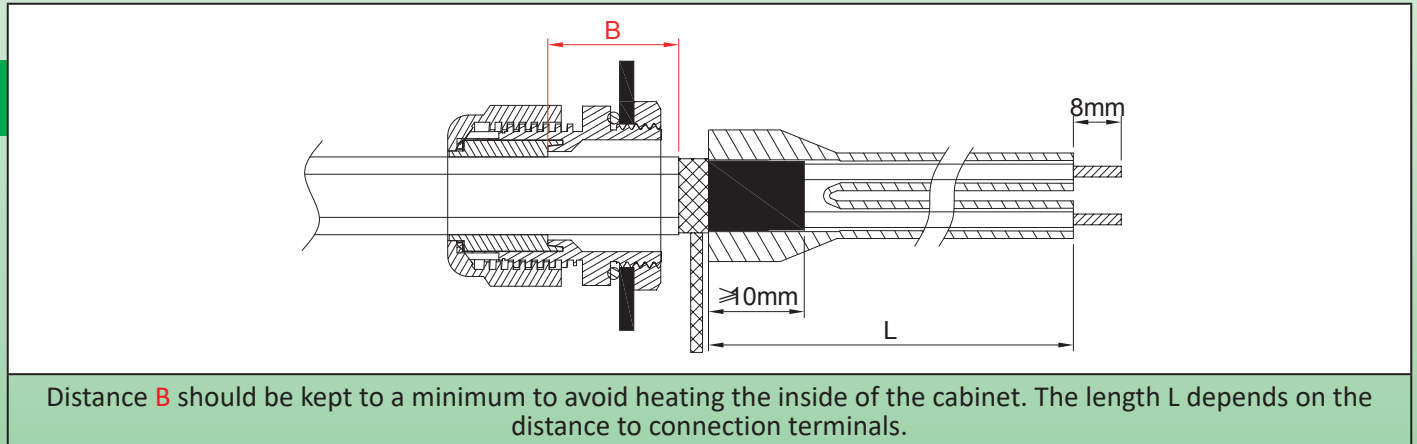

Steps of re-insulation of self-regulating heating cable bus wires after removing the heating zone, **with cable gland crossing.**



<p>1</p>	<p>2</p> <p>* 6YTTL04</p>
<p>1: Slide the cable gland compression nut on the cable, then the sealing gasket at the cable dimension.</p>	<p>2: Remove the external jacket on the requested length.</p>
<p>3</p>	<p>4</p>
<p>3: Unweave the braid on all this length with a tool with round edges or a screw driver. (For more details about this step #2, read the technical introduction).</p>	<p>4: Twist the braid to make a round wire.</p>

* These exclusive tools are available in accessories section

Sheathing and insulation boot for self-regulating heating cable conductors **after removal of the heating zone.**

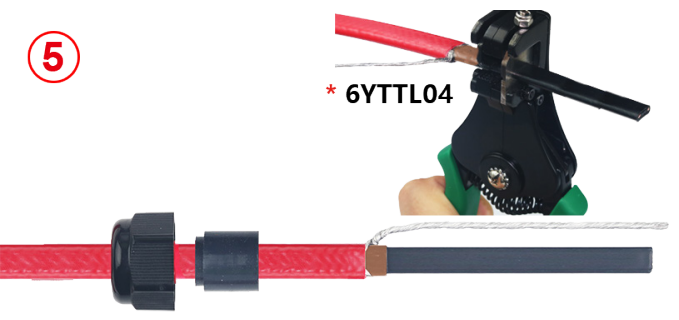
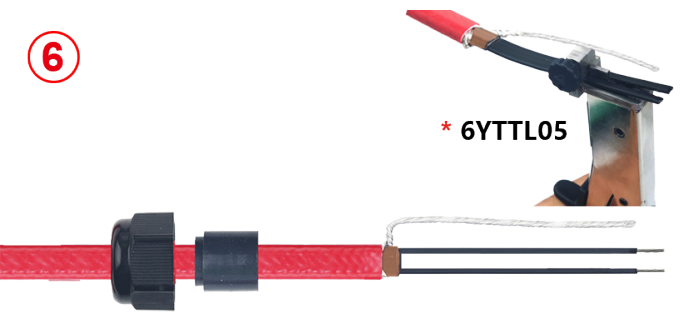
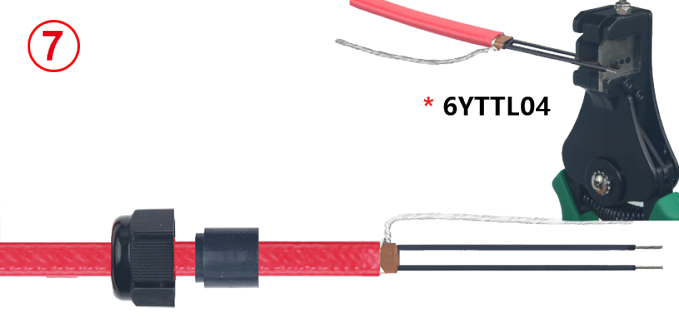
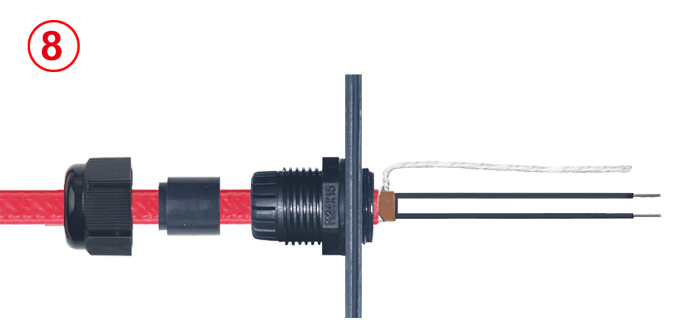

Because of permanent improvement of our products, drawings, descriptions, features used on these data sheets are for guidance only and can be modified without prior advice

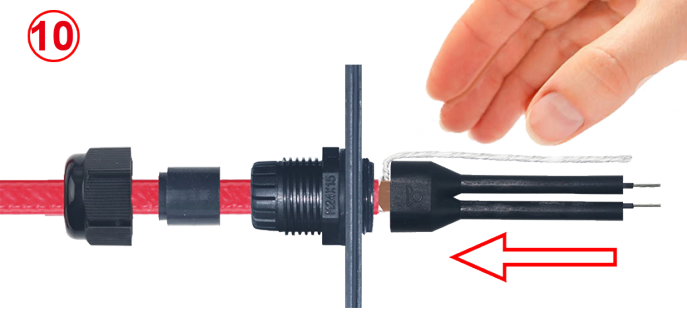
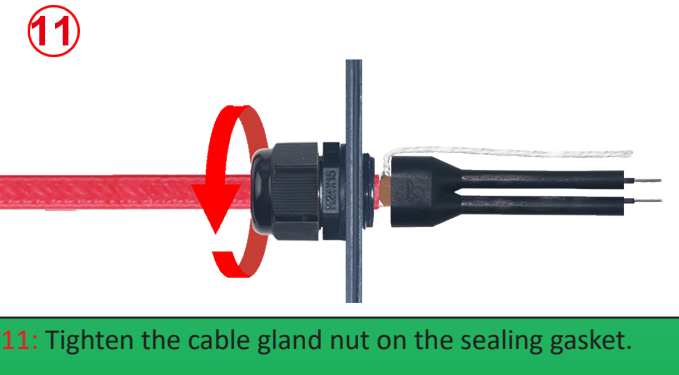
<p>5</p>  <p>* 6YTTL04</p>	<p>6</p>  <p>* 6YTTL05</p>
<p>5: Remove the electric insulation sleeving on the requested length.</p>	<p>6: Cut and remove the heating section between the two bus wires on the requested length.</p>
<p>7</p>  <p>* 6YTTL04</p>	<p>8</p> 
<p>7: Strip off the semiconductor plastic remaining on the bus wire ends to the requested length.</p>	<p>8: Push the cable through the cable gland.</p>
<p>9</p> 	<p>10</p> 
<p>9: Pour silicone resin (RTV) in the wires input hole of the silicone boot</p>	<p>10: Slide the insulating boot over the conductors of the heating cables, leaving the earth conductor outside, or with the earth conductor inside if the boot has 3 tubes.</p>
<p>11</p> 	
<p>11: Tighten the cable gland nut on the sealing gasket.</p>	

* These exclusive tools are available in accessories section



Heating wires stripping dimensions **with foot gasket crossing.**

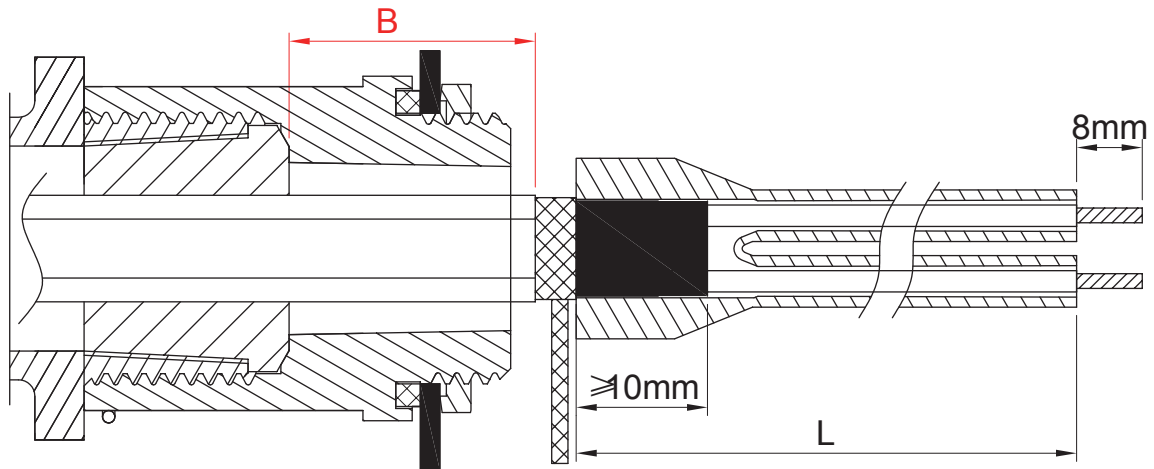

Distance **B** should be kept to a minimum to avoid heating the inside of the cabinet. The length **L** depends on the distance to connection terminals.

Steps of re-insulation of self-regulating heating cable bus wires after removing the heating zone, **with foot gasket crossing.**

<p>1</p> <p>* 6YTTL04</p>	<p>2</p>
<p>1: Cut the cable, remove the external jacket on the requested length.</p>	<p>2: Unweave the braid on all this length with a tool with round edges or a screw driver. (For more details about this step #2, read the technical introduction)</p>
<p>3</p>	<p>4</p> <p>* 6YTTL04</p>
<p>3: Twist the braid to make a round wire.</p>	<p>4: Remove the electric insulation sleeving on the requested length</p>

* These exclusive tools are available in accessories section

Sheathing and insulation boot for self-regulating heating cable conductors **after removal of the heating zone.**



<p style="text-align: center;">5</p> <p style="text-align: center;">* 6YTTL05</p>	<p style="text-align: center;">6</p> <p style="text-align: center;">* 6YTTL04</p>
<p>5: Cut and remove the heating section between the two bus wires on the requested length</p>	<p>6: Strip off the semiconductor plastic remaining on the bus wire ends to the requested length.</p>
<p style="text-align: center;">7</p>	<p style="text-align: center;">8</p>
<p>7: Cut the stripped bus wires and the ground wire to the requested length.</p>	<p>8: Place the foot on the heating cables and on the temperature sensor cable, bringing them out from above, then slide the gasket over the cables. The outer insulating sheath must protrude from the gasket.</p>
<p style="text-align: center;">9</p>	<p style="text-align: center;">10</p>
<p>9: Pour silicone resin (RTV) in the boot wires input hole</p>	<p>10: Slide the insulating sleeves over the conductors of the heating cables, leaving the earth conductor outside.</p>
<p style="text-align: center;">11</p> <p style="text-align: center;">CLICK</p>	
<p>11: Compress the seal by screwing the upper part of the foot. When tightening is complete, a small spring comes to block the assembly (To disassemble, it is necessary to remove this small semi-circular spring).</p>	

* These exclusive tools are available in accessories section

M20 cable gland, short thread, in black PA6, IP68, with seals for round and oblong cables



Material	Thread	Round cables diameter	Sizes of oblong cables		Type
PA6	M20	4mm ~ 12mm	4 × 11mm ~ 6 × 13mm		

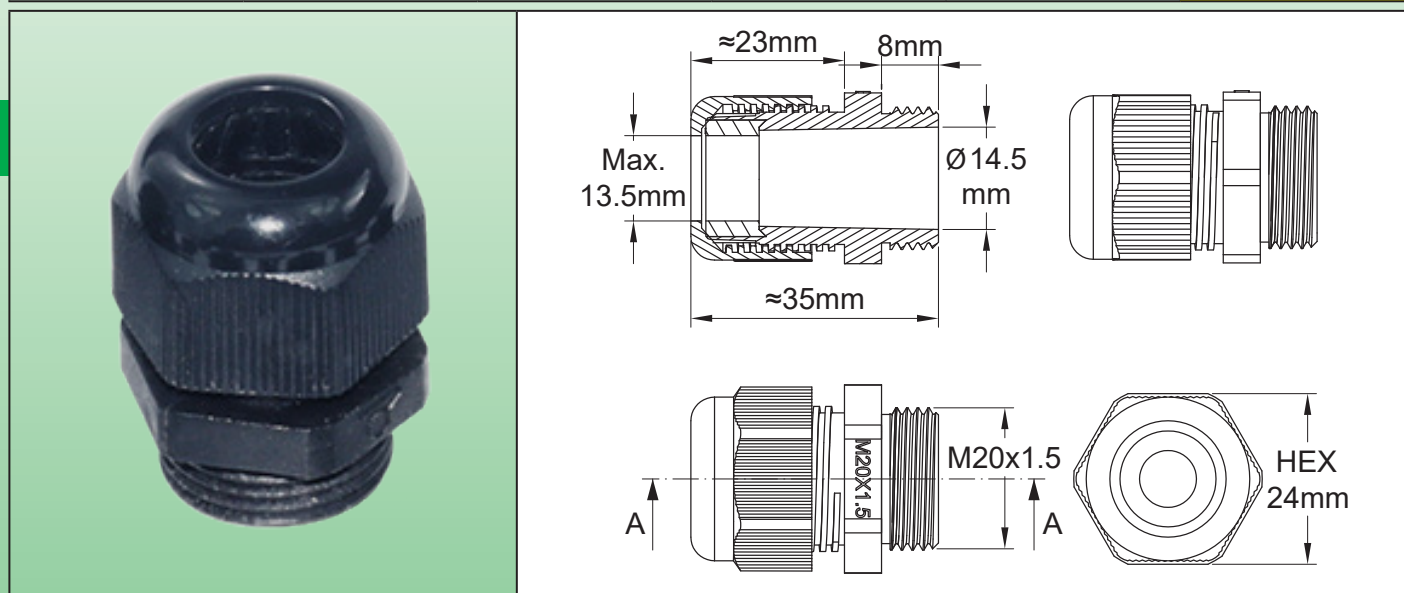

Applications

These cable glands have a **reduced length of thread**, this allows to mount them on enclosures with a thin wall, without too much encroaching on the interior space. Their design allows to use seals for **round and oblong cables**.

Main features

Ingress protection: IP68

Vibration resistance: Self-locking compression nut.

Material of the body: PA6 UL94V2

Allowable cables dimensions: Round cables up to 12mm diameter and oblong cable up to 13 × 6mm.

Seals material: 65 shore silicone or NBR 70 shore.

For more information on tightening torques and cable pull force, see the technical introduction.

Main references

Cables diameter	Seal material	References without M20 thread gasket	References with NBR O-ring M20 thread gasket	References with M20 thread flat gasket in silicone	References with NBR O-ring M20 thread gasket and locknut	References with M20 thread flat gasket in silicone and locknut
4mm ~ 8mm	NBR 70 shore	6YTPEM20S040080N	6YTPEM20S040080N	6YTPEM20S040080N	6YTPEM20S040080N	6YTPEM20S040080N
	Silicone 65 shore	6YTPEM20S040080S	6YTPEM20S040080S	6YTPEM20S040080S	6YTPEM20S040080S	6YTPEM20S040080S
8mm ~ 12mm	NBR 70 shore	6YTPEM20S080120N	6YTPEM20S080120N	6YTPEM20S080120N	6YTPEM20S080120N	6YTPEM20S080120N
	Silicone 65 shore	6YTPEM20S080120S	6YTPEM20S080120S	6YTPEM20S080120S	6YTPEM20S080120S	6YTPEM20S080120S
4 × 11mm ~ 6 × 13mm	NBR 70 shore	6YTPEM20SF60130N	6YTPEM20SF60130N	6YTPEM20SF60130N	6YTPEM20SF60130N	6YTPEM20SF60130N
	Silicone 65 shore	6YTPEM20SF60130S	6YTPEM20SF60130S	6YTPEM20SF60130S	6YTPEM20SF60130S	6YTPEM20SF60130S

M20 cable gland, short thread, in black PA6, IP68, with seals for round and oblong cables



Because of permanent improvement of our products, drawings, descriptions, features used on these data sheets are for guidance only and can be modified without prior advice

Cables diameter	Seal material	References without M20 thread gasket	References with NBR O-ring M20 thread gasket	References with M20 thread flat gasket in silicone	References with NBR O-ring M20 thread gasket and locknut	References with M20 thread flat gasket in silicone and locknut
Set of all dimensions*	NBR 70 shore	6YTPM20SSRF000N	6YTPFM20SSRF000N	6YTPGM20SSRF000N	6YTPIM20SSRF000N	6YTPKM20SSRF000N
	Silicone 65 shore	6YTPM20SSRF000S	6YTPFM20SSRF000S	6YTPGM20SSRF000S	6YTPIM20SSRF000S	6YTPKM20SSRF000S

* Set of seals for all dimensions of round and oblong cables, with only one cable gland body.

Spare parts (References for purchasing as spare parts)

 $\varnothing 8\text{mm}$, 7.5mm, $\varnothing 16.4\text{mm}$	 $\varnothing 10\text{mm}$, 7.5mm, $\varnothing 16.4\text{mm}$	 $\varnothing 13\text{mm}$, 6mm, 7.5mm, $\varnothing 16.4\text{mm}$			
M20 seal for round cables from 4 to 8mm		M20 seal for oblong cables from 4 x 11mm to 6 x 13mm			
NBR	Silicone	NBR	Silicone	NBR	Silicone
66JGN08075164	66JGT08075164	66JGN10075164	66JGT10075164	66JGNF6075164130	66JGTF6075164130
Locknut, M20x1.5, PA6 black	 HEX 25mm, 4.5mm, M20x1.5		66NCM20545H25		
Flat external silicone gasket, 65 shore	 $\varnothing 18.5\text{mm}$, $\varnothing 26.5\text{mm}$, 1.8mm		66JPT18518265		
O-ring type external gasket, NBR	 $\varnothing 18.5\text{mm}$, $\varnothing 2\text{mm}$		66JRN18520225		

M24 cable gland, short thread, in black PA6, IP68, with seals for round and oblong cables



Material	Thread	Round cables diameter	Sizes of oblong cables		Type
PA6	M24	6mm ~ 14mm	8 × 5mm ~ 14.2 × 9.2mm		

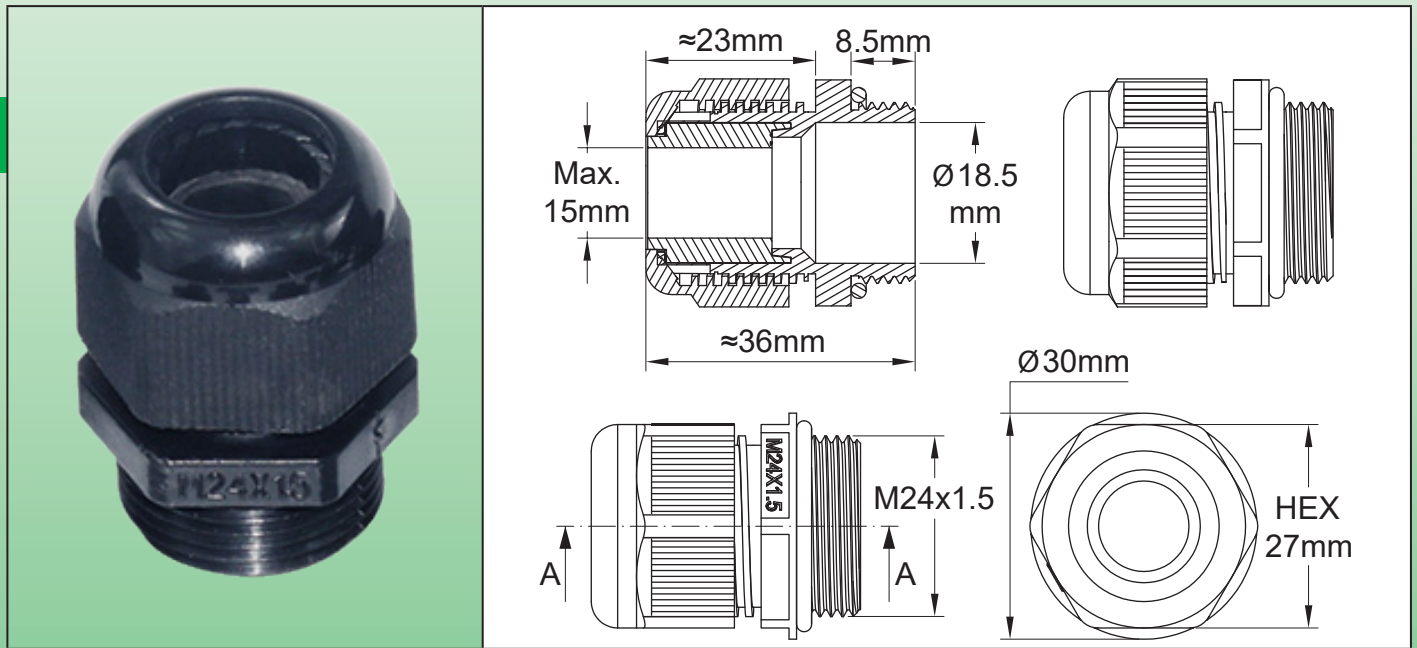

Applications

This cable gland has been developed for applications in which the **standard M25 model is too bulky**. The reduced length of the thread (8.5mm) makes it possible to mount it on enclosures with a thin wall, without too much encroaching on the interior space. Its design allows to use seals for **round and oblong cables of all usual dimensions of flexible heating cables**.

Main features

Ingress protection: IP68

Vibration resistance: Self-locking compression nut.

Material of the body: PA6 UL94V2

Allowable cables dimensions: Round cables up to 14mm diameter and oblong cable up to 14.2 × 9.2mm.

Seals material: 65 shore silicone or NBR 70 shore.

For more information on tightening torques and cable pull force, see the technical introduction.

Main references

Cables diameter	Seal material	References without M24 thread gasket	References with NBR O-ring M24 thread gasket	References with M24 thread flat gasket in silicone	References with NBR O-ring M24 thread gasket and locknut	References with M24 thread flat gasket in silicone and locknut
6mm ~ 8mm	NBR 70 shore	6YTPEM24S060080N	6YTPFM24S060080N	6YTPTGM24S060080N	6YTPIP24S060080N	6YTPKM24S060080N
	Silicone 65 shore	6YTPEM24S060080S	6YTPFM24S060080S	6YTPTGM24S060080S	6YTPIP24S060080S	6YTPKM24S060080S
8mm ~ 12mm	NBR 70 shore	6YTPEM24S080120N	6YTPFM24S080120N	6YTPTGM24S080120N	6YTPIP24S080120N	6YTPKM24S080120N
	Silicone 65 shore	6YTPEM24S080120S	6YTPFM24S080120S	6YTPTGM24S080120S	6YTPIP24S080120S	6YTPKM24S080120S

M24 cable gland, short thread, in black PA6, IP68, with seals for round and oblong cables



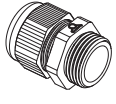
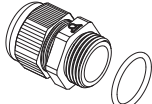
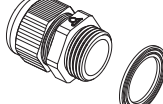
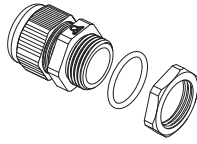
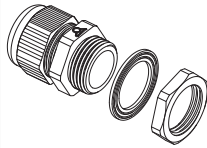

Because of permanent improvement of our products, drawings, descriptions, features used on these data sheets are for guidance only and can be modified without prior advice

Cables diameter	Seal material	References without M24 thread gasket	References with NBR O-ring M24 thread gasket	References with M24 thread flat gasket in silicone	References with NBR O-ring M24 thread gasket and locknut	References with M24 thread flat gasket in silicone and locknut
						
10mm~14mm	NBR 70 shore	6YTPEM24S100140N	6YTPFM24S100140N	6YTPGM24S100140N	6YTPIM24S100140N	6YTPKM24S100140N
	Silicone 65 shore	6YTPEM24S100140S	6YTPFM24S100140S	6YTPGM24S100140S	6YTPIM24S100140S	6YTPJM24S100140S
8 × 5mm ~ 9.5 × 6mm	NBR 70 shore	6YTPEM24SF60095N	6YTPFM24SF60095N	6YTPGM24SF60095N	6YTPIM24SF60095N	6YTPKM24SF60095N
	Silicone 65 shore	6YTPEM24SF60095S	6YTPFM24SF60095S	6YTPGM24SF60095S	6YTPIM24SF60095S	6YTPJM24SF60095S
9.5 × 2.5mm ~ 11 × 3.5mm	NBR 70 shore	6YTPEM24SF35110N	6YTPFM24SF35110N	6YTPGM24SF35110N	6YTPIM24SF35110N	6YTPKM24SF35110N
	Silicone 65 shore	6YTPEM24SF35110S	6YTPFM24SF35110S	6YTPGM24SF35110S	6YTPIM24SF35110S	6YTPJM24SF35110S
11 × 4mm ~ 13 × 6mm	NBR 70 shore	6YTPEM24SF60130N	6YTPFM24SF60130N	6YTPGM24SF60130N	6YTPIM24SF60130N	6YTPKM24SF60130N
	Silicone 65 shore	6YTPEM24SF60130S	6YTPFM24SF60130S	6YTPGM24SF60130S	6YTPIM24SF60130S	6YTPJM24SF60130S
12.5 × 8mm ~ 14.2 × 9.2mm	NBR 70 shore	6YTPEM24SF92142N	6YTPFM24SF92142N	6YTPGM24SF92142N	6YTPIM24SF92142N	6YTPKM24SF92142N
	Silicone 65 shore	6YTPEM24SF92142S	6YTPFM24SF92142S	6YTPGM24SF92142S	6YTPIM24SF92142S	6YTPJM24SF92142S
Set of all dimensions*	NBR 70 shore	6YTPEM24SSRF000N	6YTPFM24SSRF000N	6YTPGM24SSRF000N	6YTPIM24SSRF000N	6YTPKM24SSRF000N
	Silicone 65 shore	6YTPEM24SSRF000S	6YTPFM24SSRF000S	6YTPGM24SSRF000S	6YTPIM24SSRF000S	6YTPJM24SSRF000S

* Set of seals for all dimensions of round and oblong cables, with only one cable gland body.

Spare parts (References for purchasing as spare parts)

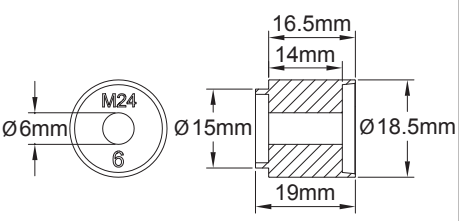
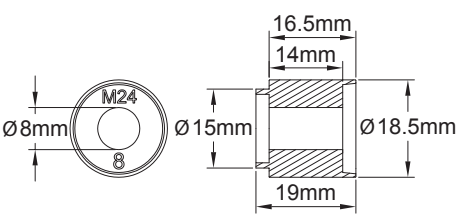
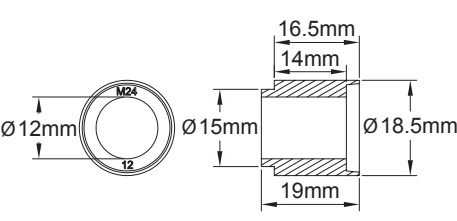
					
					
M24 seal for round cables from 6 to 8mm		M24 seal for round cables from 8 to 12mm		M24 seal for round cables from 10mm to 14mm	
NBR	Silicone	NBR	Silicone	NBR	Silicone
66JGN080P5185	66JGT080P5185	66JGN120P5185	66JGT120P5185	66JGN140P5185	66JGT140P5185

M24 cable gland, short thread, in black PA6, IP68, with seals for round and oblong cables



M24 seal for oblong cables from 8 × 5mm to 9.5 × 6mm		M24 seal for oblong cables from 9.5 × 2.5mm to 11 × 3.5mm		M24 seal for oblong cables from 11 × 4mm to 13 × 6mm		M24 seal for oblong cables from 12.5 × 8mm to 14.2 × 9.2mm	
NBR	Silicone	NBR	Silicone	NBR	Silicone	NBR	Silicone
66JGNF60P5185095	66JGTF60P5185095	66JGNF35P5185110	66JGTF35P5185110	66JGNF60P5185142	66JGTF60P5185142	66JGNF92P5185142	66JGTF92P5185142
Locknut, M24x1.5, PA6 black						66NCM24560H30	
Flat external silicone gasket, 65 shore						66JPT22518300	
O-ring type external gasket, NBR						66JRN22520245	

Because of permanent improvement of our products, drawings, descriptions, features used on these data sheets are for guidance only and can be modified without prior advice

Stainless steel devices for mounting **temperature sensors probes and thermostat bulbs** on pipes surface.



Because of permanent improvement of our products, drawings, descriptions, features used on these data sheets are for guidance only and can be modified without prior advice

Material	Compatibility	Mounting on pipe	Assembly		Type
Stainless steel	Thermostat bulbs and temperature sensors probes	Hose metal clamps	On pipe surface		6YTBA

Mounting bracket for temperature sensors dia 5 and 6mm, probe length 40mm max.

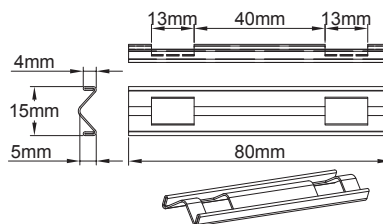

Mounting bracket for thermostat bulbs dia 5 and 6mm, probe length 120mm max.

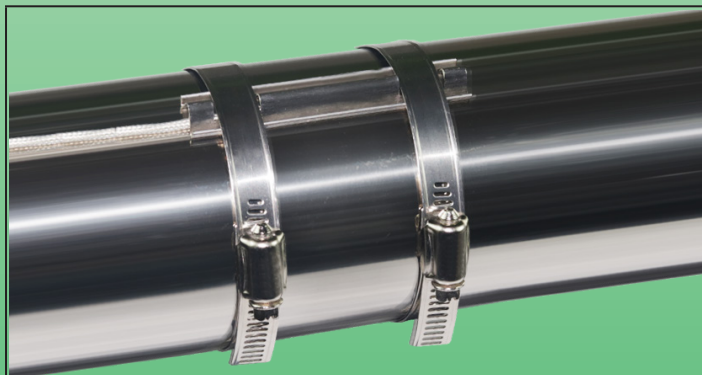
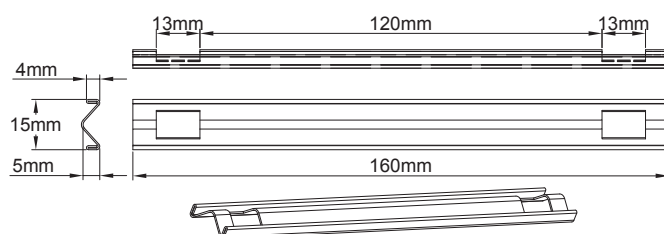
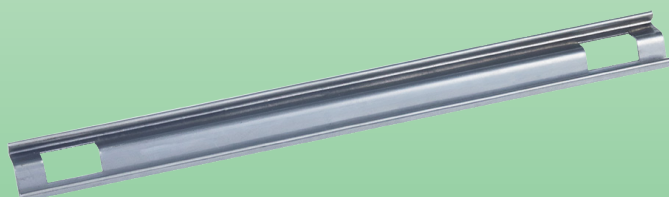

Example of the **temperature sensor** model after installation

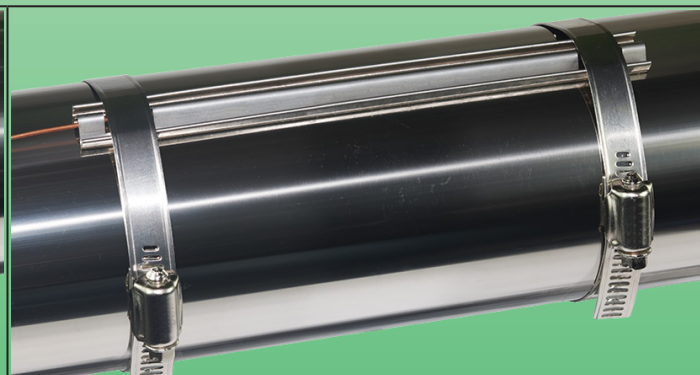

Example of the **thermostat bulb** model after installation

Applications

The main problem with measuring the surface temperature of pipes is to maintain permanent thermal contact between the temperature measuring device and the tube. These plates, specially developed for this application, **are flexible and elastic**, in order to keep their tightness on the tube permanently, **despite thermal expansions**. They adapt automatically to the diameter of the tube and do not deform the measuring devices.

Main features

Sensor diameter: 5 to 6.5mm.

Material: 304 stainless steel, 0.5mm thickness

Fixing: By metal hose clamps (Nylon cable ties are not recommended).

Part numbers

Length 80mm	6YTBA015503040H0
Length 160mm	6YTBA015503040P0

Bands for mounting electric heat tracing cables on pipes, on roofs or on the floor.



Material	Heating cables fixing	Mounting on field	Assembly		Type
Stainless steel	Bendable tabs	Holes for screws, or metal ties	Floor and roofs		6YTBT
Heat tracing band, 12mm width, with 25mm pitch, in reel					
Heat tracing band, 12mm width, with 25mm pitch, in 3 holes strips					
Heat tracing band 20mm width, with 50mm pitch					
Heat tracing band, 20mm width, with 50mm pitch, in 3 holes strips					
Heat tracing band 20mm width, with 100mm pitch					
Heat tracing band, 20mm width, with 100mm pitch, in 3 holes strips					

Because of permanent improvement of our products, drawings, descriptions, features used on these data sheets are for guidance only and can be modified without prior advice

Bands for mounting electric heat tracing cables on pipes, on roofs or on the floor.



Because of permanent improvement of our products, drawings, descriptions, features used on these data sheets are for guidance only and can be modified without prior advice

<p>Example of network made between two bands with 50mm pitch.</p>	<p>Example of heat tracing made between two bands with 25mm pitch.</p>	<p>Method of fixing a 20mm strip with 100mm pitch on a steel mesh before concrete pouring. (Backside view).</p>

Applications

These metal bands are intended for the production of **networks of heating cables**, ensuring their mechanical holding, their spacing, and their fixing on a support. They are used for example for holding on the ground, before the concrete is laid, in the construction of ramps and antifreeze heating passages, or heated floors in cold rooms, but also for snow and ice melting on roofs.

Main features

Material: 304 stainless steel or zinc plated steel.

Fixing: These strips have holes at regular intervals allowing them to be fixed on a support, such as a wall, a reinforcement grid for concrete, or a roof.

Versions: In rolls of 25 meters under cardboard reel, (for use in continuous strips for unrolling on the ground) or in small strips of 2 hooks and 3 holes for fixing on roofs.

Part numbers

Width	Pitch	Maximum size of heating cable	Material	Reference in reels	Reference of 3 holes strips
12mm	25mm	Ø8mm/9.5 × 6mm	304 Stainless-steel	6YBT01250304B25	6YBT01250304BE5
12mm	25mm	Ø8mm/9.5 × 6mm	Zinc plated steel	6YBT01250SGCB25	6YBT01250SGCBE5
20mm	50mm	Ø8mm/9.5 × 6mm	304 Stainless-steel	6YBT02025304C25	6YBT02025304CK0
20mm	50mm	Ø8mm/9.5 × 6mm	Zinc plated steel	6YBT02025SGCC25	6YBT02025SGCCK0
20mm	100mm	Ø12mm/14.2 × 9.2mm	304 Stainless-steel	6YBT02025304D25	6YBT02025304DU0
20mm	100mm	Ø12mm/14.2 × 9.2mm	Zinc plated steel	6YBT02025SGCD25	6YBT02025SGCDU0

Supports in stainless steel for mounting **M20x1.5 disc thermostats and M20x1.5 temperature sensors** on pipe walls.



Because of permanent improvement of our products, drawings, descriptions, features used on these data sheets are for guidance only and can be modified without prior advice

Material	Fixing	Distance to pipe	Assembly on box		Type
Stainless steel	On pipe	0mm	M20 × 1.5		6YTQS

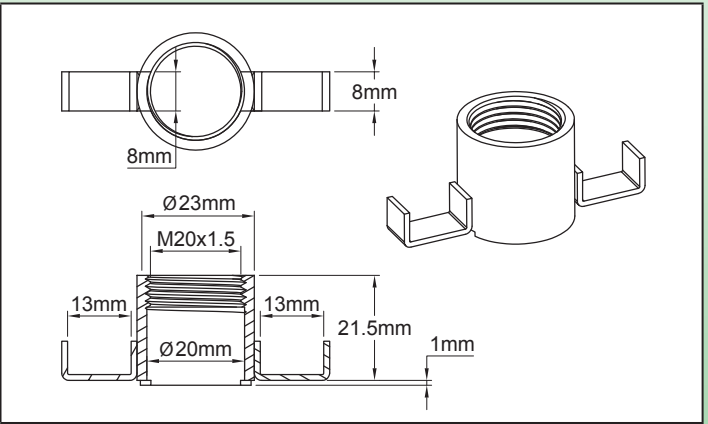

Example of assembly on pipe of disc thermostat type 49JB



Example of assembly on pipe of Pt100 temperature sensor type TSJB

Applications

This stainless-steel device is used to **mount temperature sensors or fixed temperature thermostats** with M20x1.5 threads **on pipe**. The contact with the pipe wall is preserved, despite the thermal expansions, by the elasticity of the two lateral legs.

Main features

Material: 304 stainless steel. Can also be produced in 316 stainless steel (MOQ apply).

Disc thermostat or temperature sensor fixing: By the M20x1.5 thread.

Compatible types: TSJB, TNJB, TPJB, TJJB, 49JB.

Pipe mounting: By metal hose clamp or by Nylon cable ties.

Part numbers (In 304 stainless steel*)

Reference	Material
6YTQS2420	304 Stainless-steel
6YTQS2620	316 Stainless-steel

* Nickel plated steel available on request.

Stainless steel mounting feet for connection boxes, snapped-on or screwed on the bottom of the boxes. Mounting on pipes by nylon ties or metal clamps.



Because of permanent improvement of our products, drawings, descriptions, features used on these data sheets are for guidance only and can be modified without prior advice

Material	Fixing	Distance to pipe	assembly on box		Type
Stainless steel	On pipe	~50mm	Screws or Snap-on		6YTPT 6YTQT

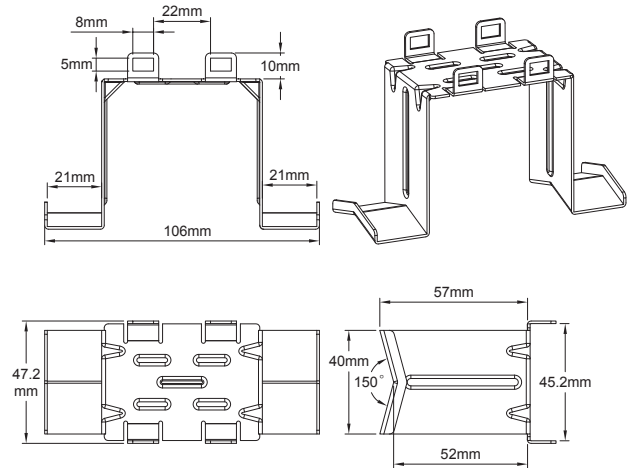

Type 6YTPT/6YTQT

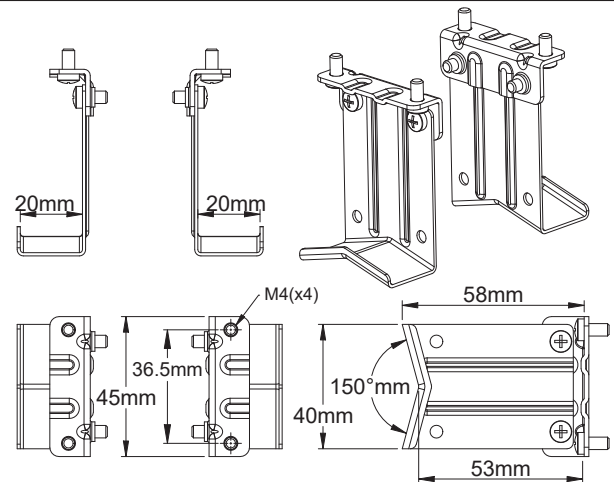

Type 6YTPT/6YTQT

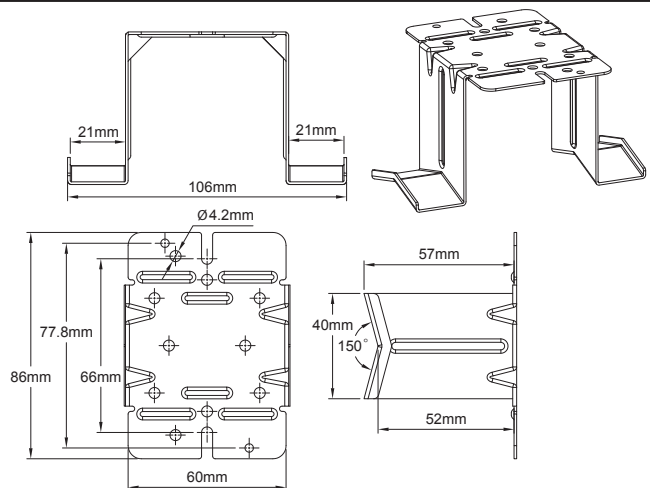

Type 6YTPT/6YTQT

Stainless steel mounting feet for connection boxes, snapped-on or screwed on the bottom of the boxes. Mounting on pipes by nylon ties or metal clamps.



Applications

These metal brackets allow to mount connection boxes for heating cables on pipes, keeping a distance of about 50mm with the pipes, which allows thermal insulation and its protection to be installed. The snap-in models allow this insulation to be carried out after the heating cables have been laid and before the boxes have been laid and connected. **The removable legs, fixed by 2 screws on the side of the bracket body can be mounted on the pipe before the thermal insulation, then requesting only two straight cut on it before to screw the legs on the bracket body.** The use of stainless-steel limits thermal conduction by the feet from the pipe to the box.

Main features

Material: 304 stainless steel. Can also be produced in 316 stainless steel and in zinc plated steel (MOQ apply).

Pipe mounting: By metal hose clamp or by Nylon cable ties.

Main part numbers (In 304 stainless steel*)

Reference	Compatibility	Type of mounting on the box
6YTPTE440	Boxes of type Y50 and Y51	Snap-on
6YTPTW46	Boxes of type Y9 (Catalogue 4)	Snap-on
6YTPTE499	Boxes of type Y27, Y28, Y8	M4 screws

* Economic version in galvanized steel: replace the 7th character (4) with S. Food version in stainless steel 316: replace the 7th character (4) with 6.

Because of permanent improvement of our products, drawings, descriptions, features used on these data sheets are for guidance only and can be modified without prior advice

Heat tracing pipe mounting feet for connection boxes, **includes gasket for flat self-regulating cables up to 6 x13mm, and for temperature sensor. Self-locking of the gasket tightening. (1" thread).**



Material	Fixing	Distance to pipe	Assembly on box		Type
PPS	On pipe	~120mm	Screwed		6YTPP

1: Lower part of the foot; **2:** Heating cable and temperature sensor sealing gasket; **3:** Upper part of the foot;
4: Box gasket; **5:** Box locking nut; **6:** Bus wires insulator boot; **7:** Self locking spring; **8:** Self locking spring pin passage
9: Locking blind hole.

Applications

These PPS feet allow mounting of heating cable connection boxes on the pipes, keeping a space of about 120mm with the pipes, which allows thermal insulation and its protection to be installed. The foot also serves as a **waterproof passage for one or two heating cables and possibly a temperature sensor cable**. The tightening of the seal is self-locking to avoid prohibited unscrewing.

Main features

Boot material: PPS (Polyphenyl sulphide). This hard, semi-crystalline material has exceptional chemical resistance, good thermal stability and high resistance to fire and high temperatures.

Sealing gasket: Silicone, with many possible combinations of cable holes section. Special dimensions on request.

Stripped bus wire insulation boot: Supplied in standard.

Assembly on the box: By a 32.5mm diameter hole drill. The tightening is done by a grooved nut, with locking lugs. In addition to a large part of the boxes in this catalog, these feet are also compatible **with all boxes available on the market** whose size allows to drill a 32.5mm hole on one of their faces.

Pipe mounting: By 2 metal hose clamps or by 2 Nylon cable ties.

Main part numbers

Reference	Gasket type	Compatibility with products of this catalogue*
6YTPPCP98 01 B32	6YTRP01	Y29C, Y29D, Y7PB13D, Y8W-Z
6YTPPCP98 11 B32	6YTRP11	Y29C, Y29D, Y7PB13D, Y8W-Z
6YTPPCP98 21 B32	6YTRP21	Y29C, Y29D, Y7PB13D, Y8W-Z
6YTPPCP98 02 B32	6YTRP02	Y29C, Y29D, Y7PB13D, Y8W-Z
6YTPPCP98 12 B32	6YTRP12	Y29C, Y29D, Y7PB13D, Y8W-Z
6YTPPCP98 22 B32	6YTRP22	Y29C, Y29D, Y7PB13D, Y8W-Z

* These feet are also compatible **with all boxes available on the market** whose size allows to drill a 32.5mm hole on one of their faces.

Heat tracing pipe mounting feet for connection boxes, **includes gasket** for flat self-regulating cables up to 6 x13mm, and for temperature sensor. **Self-locking of the gasket tightening. (1" thread).**



Main waterproof foot sealing gaskets *

	A max.	A min.	B max.	B min.	C max.	C min.	Reference of the component **	Code in the leg reference
	3mm	2mm	11mm	9.5mm	3.5mm	2.5mm	6YTRP01	01
	3mm	2mm	13mm	11mm	6mm	4mm	6YTRP11	11
	3mm	2mm	9.5mm	8mm	6mm	5mm	6YTRP21	21
	0mm	0mm	11mm	9.5mm	3.5mm	2.5mm	6YTRP02	02
	0mm	0mm	13mm	11mm	6mm	4mm	6YTRP12	12
	0mm	0mm	9.5mm	8mm	6mm	5mm	6YTRP22	22

* The sealing gaskets are delivered with a plug allowing to close one of the 2 orifices for the heating cables, for cases where the foot uses only one heating cable.

** This reference must be used to purchase the sealing gasket alone as a spare part.

Stripping dimensions of heating cables.

(More detailed instructions are available in the technical introduction)

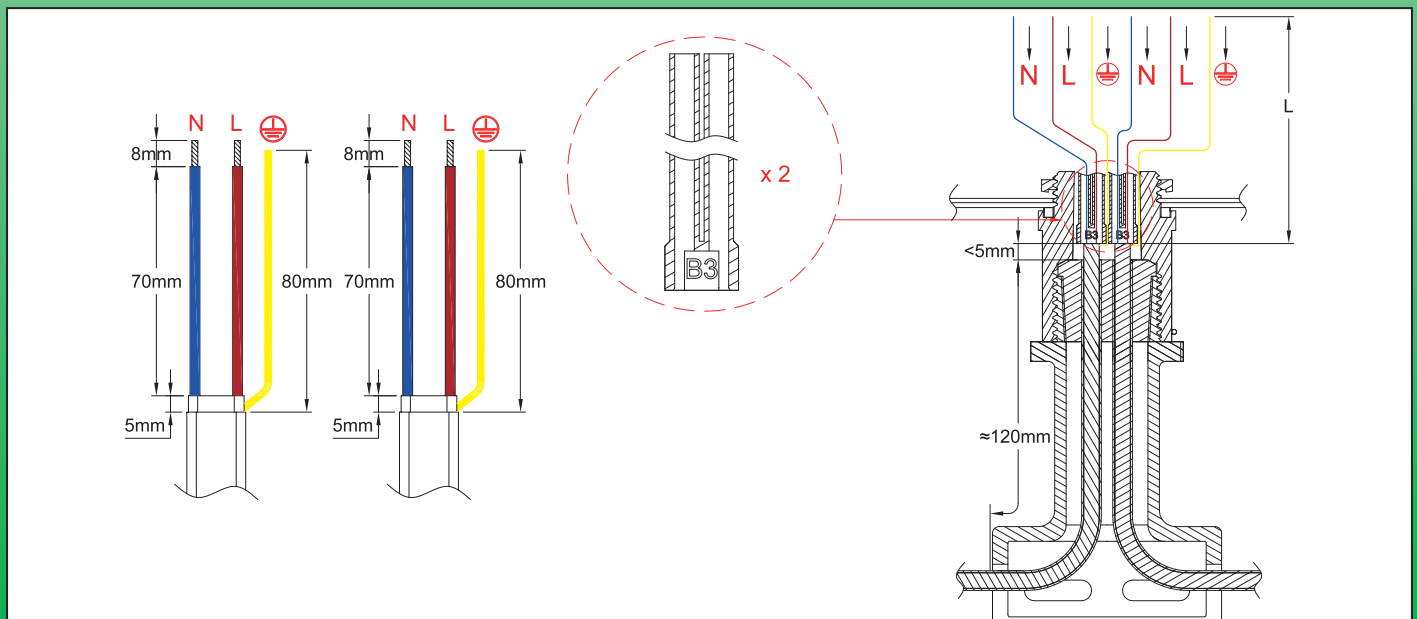





Because of permanent improvement of our products, drawings, descriptions, features used on these data sheets are for guidance only and can be modified without prior advice

Heat tracing pipe mounting feet for connection boxes, **includes gasket** for flat self-regulating cables up to 6 x13mm, and for temperature sensor. **Self-locking of the gasket tightening. (1" thread).**

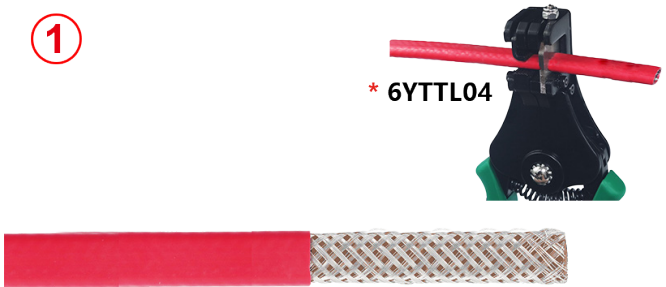

Because of permanent improvement of our products, drawings, descriptions, features used on these data sheets are for guidance only and can be modified without prior advice

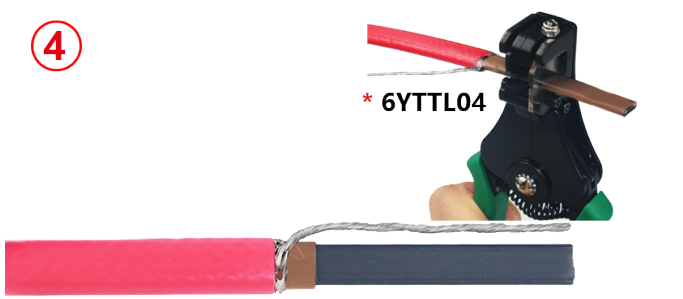
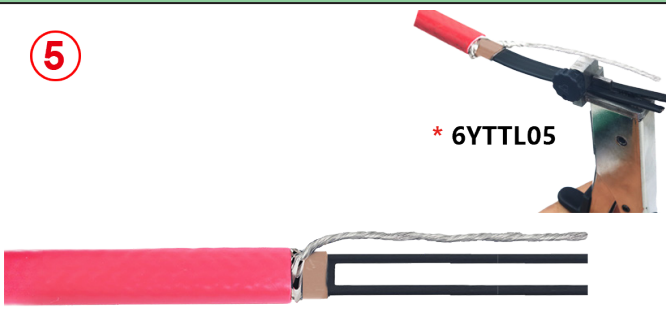
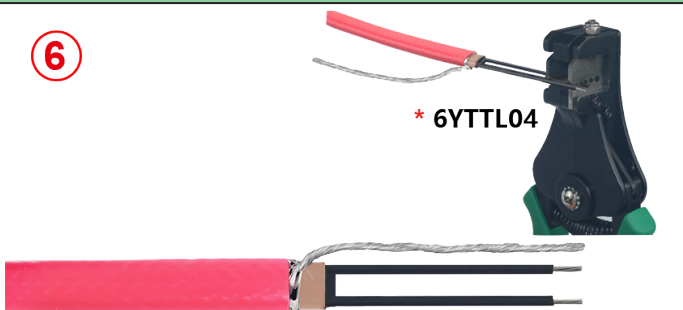
Self-regulating cables assembly steps

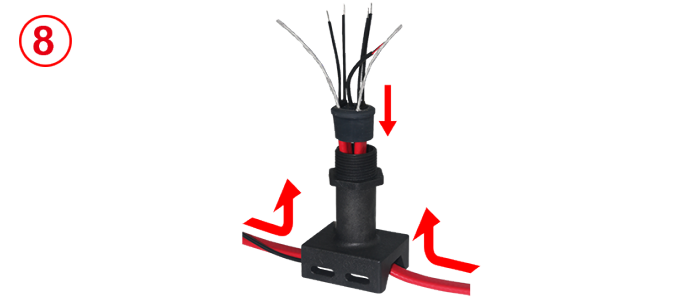
<p>1</p>  <p>* 6YTTL04</p>	<p>2</p> 
<p>1: Cut the cable, remove the external jacket on the requested length.</p>	<p>2: Unweave the braid on all this length with a tool with round edges or a screw driver. (For more details about this step #2, read the technical introduction).</p>
<p>3</p> 	<p>4</p>  <p>* 6YTTL04</p>
<p>3: Twist the braid to make a round wire.</p>	<p>4: Remove the electric insulation sleeving on the requested length</p>
<p>5</p>  <p>* 6YTTL05</p>	<p>6</p>  <p>* 6YTTL04</p>
<p>5: Cut and remove the heating section between the two bus wires on the requested length.</p>	<p>6: Strip off the semiconductor plastic remaining on the bus wire ends to the requested length.</p>
<p>7</p> 	<p>8</p> 
<p>7: Cut the stripped bus wires and the ground wire to the requested length.</p>	<p>8: Place the foot on the heating cables and on the temperature sensor cable, bringing them out from above, then slide the gasket over the cables. The outer insulating sheath must protrude from the gasket.</p>

* These exclusive tools are available in accessories section

Heat tracing pipe mounting feet for connection boxes, **includes gasket** for flat self-regulating cables up to 6 x13mm, and for temperature sensor. **Self-locking of the gasket tightening. (1" thread).**



9: Pour RTV silicone inside the main hole of the silicone boot.

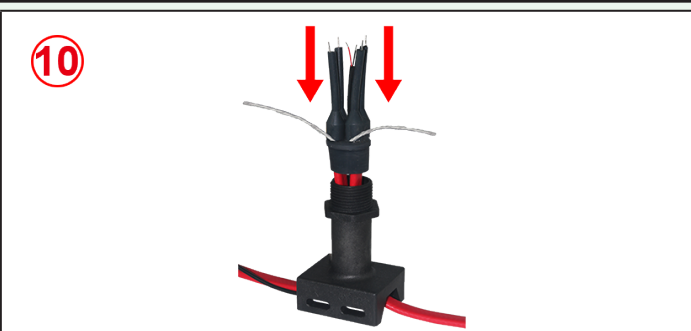

10: Slide the insulating sleeves over the conductors of the heating cables, leaving the ground conductor outside.

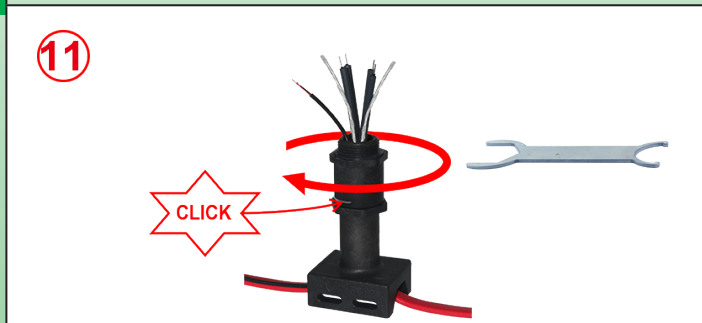

11: Compress the seal by screwing the upper part of the foot. When tightening is complete, a small spring comes to block the assembly (To disassemble, it is necessary to remove this small semi-circular spring). Then it is possible too install this leg through a 32.5mm hole on the selected enclosure.

Because of permanent improvement of our products, drawings, descriptions, features used on these data sheets are for guidance only and can be modified without prior advice

Tinned tubular copper terminals for connecting heating wire conductors end to end by **hexagonal crimping**.



Because of permanent improvement of our products, drawings, descriptions, features used on these data sheets are for guidance only and can be modified without prior advice

Material	Fixing	Wires gage		Type
Tin plated copper	Crimping	0.1mm ² ~ 2.5mm ²		6YTCO



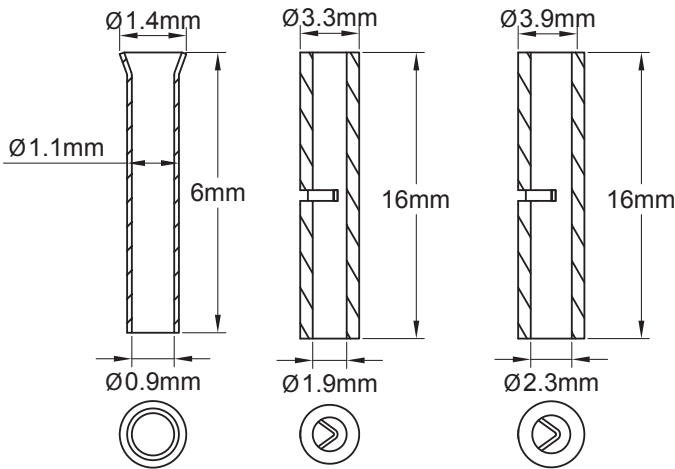

Applications

Allows the connection of conductors of different gages, including heating wires wounded on fiberglass or aramid core.

The terminals must be protected by a retractable sheath if a waterproof connection sleeve with silicone filling is not used.

This technique can be used on all types of heating wires

Main features

Material: Tin plated copper

Conductors stripping length: 7±1mm

Part numbers

Wire gauge (mm ²)	Internal diameter	Outside diameter	Part numbers (100 pcs box)
0.1 ~ 0.5	0.9	1.1	6YTCORC009011006
0.5 ~ 1.5	1.9	3.3	6YTCORC019033016
1.5 ~ 2.5	2.3	3.9	6YTCORC023036016

Selection of the plier and crimping cavity according to the cross-section of the conductor and the terminal model

Tubular connector	Tool	2 conductors dia 0.1 a 0.3mm twisted together	Conductor wounded on fiberglass core dia. 0.5 to 0.8mm	0.75mm ²	AWG18 (0.8mm ²)	1.5mm ²	AWG15 (1.65mm ²)	2.5mm ²
0.9 × 1.1	6YTTL07	Yes	No	No	No	No	No	No
1.9 × 3.3	6YTTL03	No	N°1	N°1	N°1	N°2	N°2	No
2.3 × 3.9	6YTTL03	No	No	No	No	N°2	N°2	N°3



Tinned tubular copper terminals for connecting heating wire conductors end to end by **hexagonal crimping**.



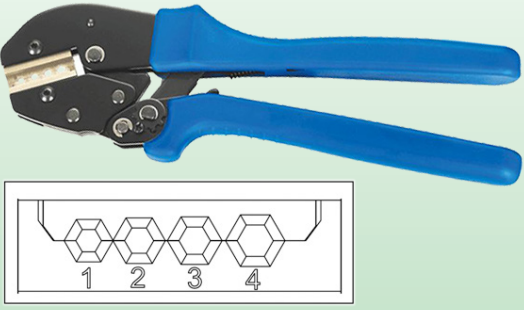

Because of permanent improvement of our products, drawings, descriptions, features used on these data sheets are for guidance only and can be modified without prior advice

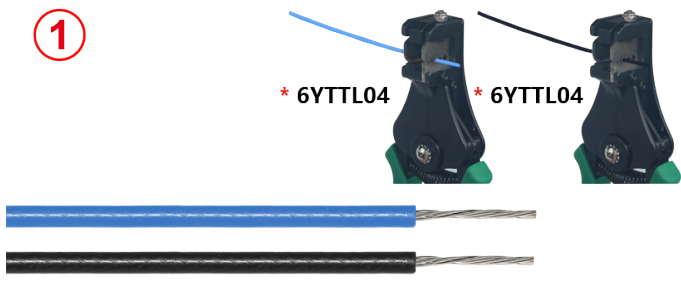
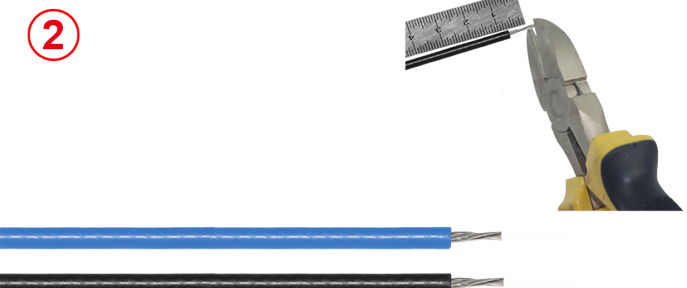
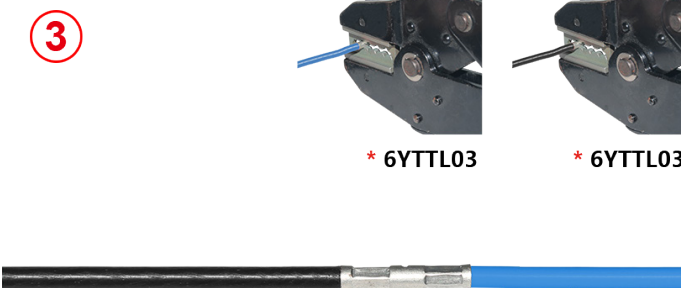
Plier reference 6YTTL07	Plier reference 6YTTL03
	

Usual methods of connecting different models of heating cables with tubular terminals. A: End-to-end stranded conductors.

<p>1</p>  <p>* 6YTTL04 * 6YTTL04</p>	<p>2</p> 
<p>1: Strip off the end of the 2 conductors.</p>	<p>2: Cut the stripped ends to the requested length.</p>
<p>3</p>  <p>* 6YTTL03 * 6YTTL03</p>	<p>4</p> 
<p>3: Crimp both conductors one after each other inside the tubular terminal.</p>	<p>4: If the connection is not used inside an elastomeric cap with silicone resin filling, insulate it electrically with a double-wall heat-shrink tubing.</p>

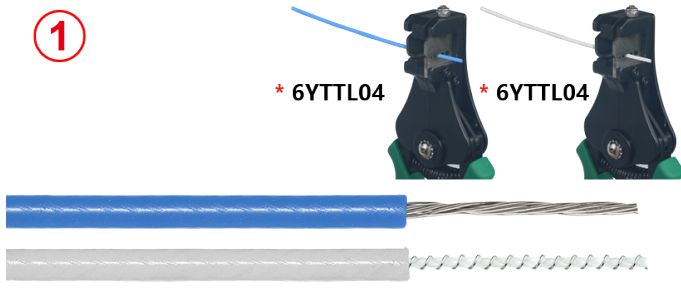
B: Multi-strand cold conductor with heating element wire wound on fiberglass or aramid core.

<p>1</p>  <p>* 6YTTL04 * 6YTTL04</p>	<p>2</p> 
<p>1: Strip off the end of the 2 conductors.</p>	<p>2: Unwound and straighten the small heating wire, then coat the fiberglass or aramid core with epoxy resin. Let it cure.</p>

* These exclusive tools are available in accessories section

Tinned tubular copper terminals for connecting heating wire conductors end to end by **hexagonal crimping**.



Because of permanent improvement of our products, drawings, descriptions, features used on these data sheets are for guidance only and can be modified without prior advice

<p>3</p>	<p>4</p> <p>* 6YTTL03 * 6YTTL03</p>
<p>3: Cut the stripped ends to the requested length. Be careful not to cut the small heating wire.</p>	<p>4: Crimp both conductors one after each other inside the tubular terminal. Let the small heating wire outside the crimping.</p>
<p>5</p>	<p>6</p>
<p>5: Wrap the small heating wire around the terminal</p>	<p>6: Tin solder the small heating wire on the terminal. If the connection is not used inside an elastomeric cap with silicone resin filling, insulate it electrically with a double-wall heat-shrink tubing.</p>

C: Two wounded heating elements (Free end of serial cable with two conductors side by side).

<p>1</p> <p>* 6YTTL04 * 6YTTL04</p>	<p>2</p>
<p>1: Strip off the end of the 2 conductors.</p>	<p>2: Unwound and straighten the small heating wire. Cut the fiberglass or aramid core.</p>
<p>3</p>	<p>4</p> <p>* 6YTTL07</p>
<p>3: Twist the 2 small heating wires together.</p>	<p>4: Slide one tubular terminal around the twisted wires and crimp.</p>

* These exclusive tools are available in accessories section

Tinned tubular copper terminals for connecting heating wire conductors end to end by **hexagonal crimping**.

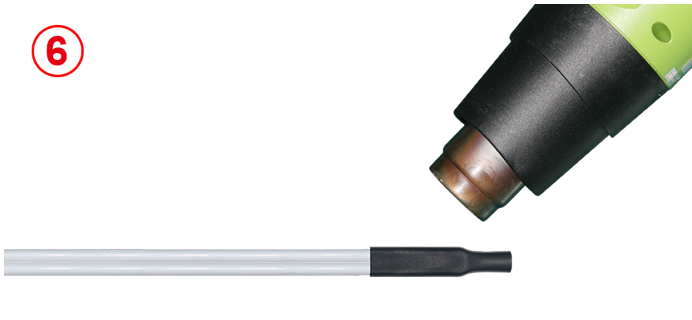

<p>5</p> 	<p>6</p> 
<p>5: Cut the heating wires protruding from the tubular terminal</p>	<p>6: If the connection is not used inside an elastomeric cap with silicone resin filling, insulate it electrically with a double-wall heat-shrink tubing.</p>

Because of permanent improvement of our products, drawings, descriptions, features used on these data sheets are for guidance only and can be modified without prior advice



Liquid RTV silicone for filling

Material	Conditioning	Temperature resistance	Vulcanizing		Type
Silicone	45ml tube	280°C	Room temperature		6YTMC

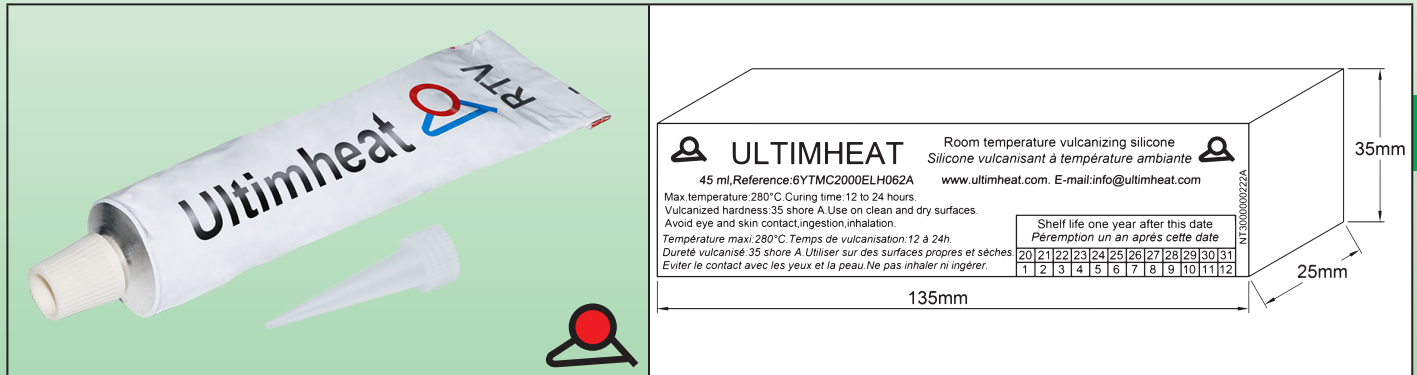

Applications

Room temperature vulcanizing silicone resin. Very smooth, **fills the silicone boots well and without bubbles**. Very good temperature resistance.

Main features

Color: Red

Packaging: 45 ml tube with special nozzle that directs the liquid silicone in the desired location without spilling.

Temperature resistance: 280°C.

Vulcanization time at room temperature: 12 to 24 hours depending on thickness.

Vulcanized hardness: 35 Shore A.

Volume resistivity: 4×10^{15} ohms/cm.

Attention, this value is reached **after** vulcanization. **The product is electrically conductive when liquid.**

Elongation: >150%.

Insulation breakdown voltage: 16KV/mm.

Adhesiveness: Very good adhesion on clean silicone surfaces, **dry and degreased**, and on the jackets of heating cables and metallic braids.

Storage: Keep in a cool and dry place (15-25°C, HR< 55%). Shelf life 12 months in unopened tube.

Packing: Tube and nozzle under carton with expiration date.

Part number

6YTMC2000ELH062A



Because of permanent improvement of our products, drawings, descriptions, features used on these data sheets are for guidance only and can be modified without prior advice



Because of permanent improvement of our products, drawings, descriptions, features used on these data sheets are for guidance only and can be modified without prior advice

Section 10

Special tools







Special tools

- Preparing the ends of heating cables and in particular cables with metallic braid and self-regulating cables can be tedious and often unfortunate and expensive. We have developed a range of hand tools to save time and achieve a professional and safe result.
- These tools are made in our factory, generally from mechanical bodies existing on the market.

Hexagonal crimping plier for **small size wires.**

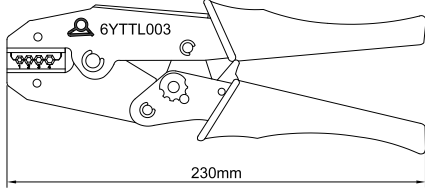

Because of permanent improvement of our products, drawings, descriptions, features used on these data sheets are for guidance only and can be modified without prior advice

Use	Wire gauge		Type
Workshop or field	0.5mm ² ~2.5mm ² (AWG22~AWG14)		6YTTL03
			
			
Case		Crimping example on 1mm ² wires	

Applications

Manual pliers with hexagonal crimping for tubular butt connectors. These pliers are used to connect a heating cable end to end to a power cable or two heating cables together. It allows quick and economical connection of conductors of equal or different dimensions.

The dimensions of the jaws have been specially studied for applications in heating cables on **small diameter conductors.**

Main features

- Allows crimping of non-insulated butt connectors according to DIN.
- Constant crimp size thanks to the ratchet system.
- The force is amplified thanks to the reduction mechanism.
- Easy cable exit thanks to the ratchet unlocking system
- Low weight (500 grs).
- Compatible butt connectors: Diameter 3.3 and 3.9 according to DIN 46267 Part 1
- Shipped inside a professional case, with 2 sets of jaws

Part number

6YTTL03

Jaws types

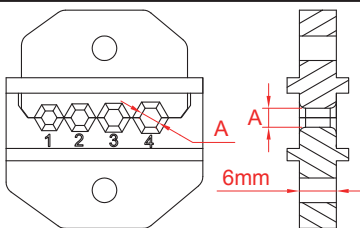
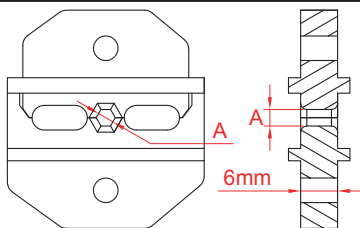
	
<p>Universal model, with 4 cavities A1=2.2mm; A2=2.5mm; A3=2.7mm; A4=3.1mm.</p>	<p>Model with one cavity, for crimping terminals with short distance from each other (A=2.2mm). Usable for crimping of models 6YTDK2</p>

Exclusive stripping pliers for heat tracing cables with **dedicated** cutting blades according to all cable dimensions.



Use	Wire gauge	Cables styles		Type
Workshop or field	0.5mm ² ~2.5mm ² (AWG22~AWG14)	Round of oblongs		

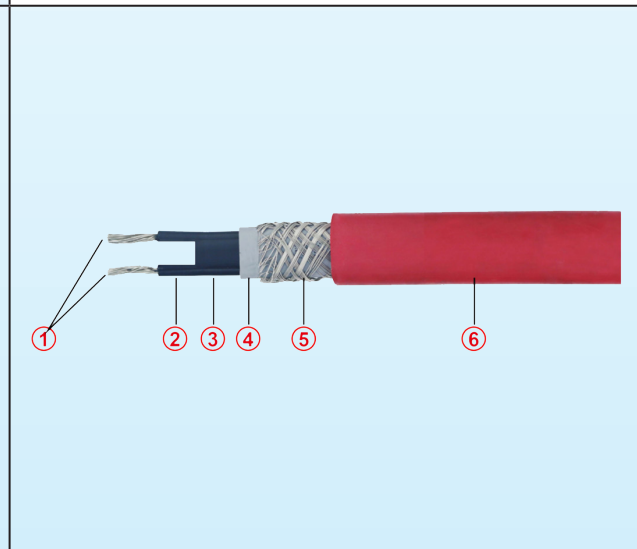
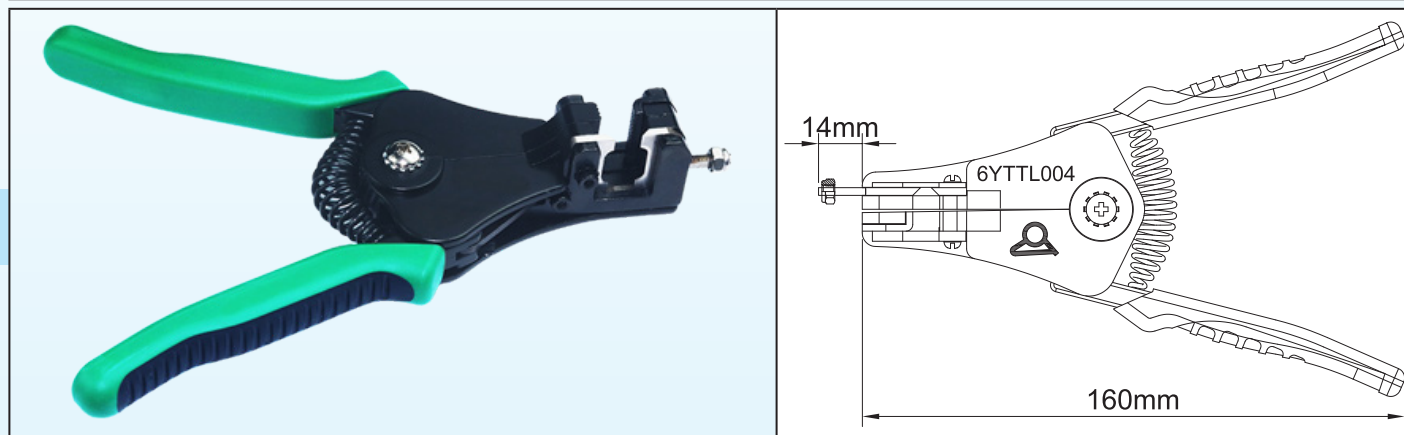

Case with all sets of stripping jaws

Common composition of a self-regulating cable
 1: Metal conductors, from 1 to 2mm²
 2: Conductors still covered with semiconductor compound (the one whose stripping is the most difficult)
 3: Heating semiconductor area
 4: Electrical insulation jacket of the heating zone
 5: Metal braid or ribbon + earth conductor
 6: Outer protection jacket

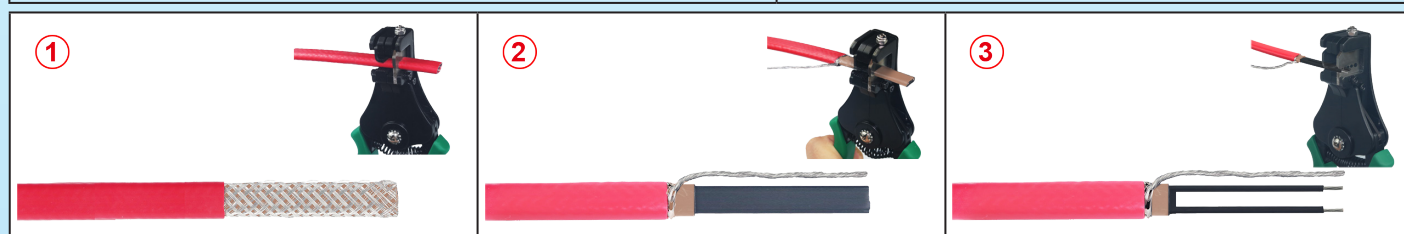

Possible operations with this tool:
 1: Remove the outer jacket
 2: Remove the electrical insulating jacket
 3: Strip the bus wires

Because of permanent improvement of our products, drawings, descriptions, features used on these data sheets are for guidance only and can be modified without prior advice

Exclusive stripping pliers for heat tracing cables with dedicated cutting blades according to all cable dimensions.



Applications

Special stripping pliers **particularly suitable for oblong heating cables with two conductors.** The stripping and stripping of these oblong conductors is a long and difficult operation, causing a lot of waste. We **have specially developed** these tools in order to reduce waste and considerably reduce installation times.

Main features

There are a whole series of models in various sizes of heating cables. These cables can have up to 4 different layers made of several materials. For more information, see the technical introduction to this catalog which describes them. These layers can be made of different materials, more or less flexible, the most rigid and difficult to remove being that of carbon filled polyethylene core used in the low and medium temperature self-regulating cables.

Jaws: They exist in two configurations.

- *Bus wire stripping jaws.* They are differentiated by the spacing of the conductors and their diameter. In the case of self-regulating cables with carbon filled polyethylene, we recommend stripping the wires one by one. **Softening the polyethylene core with a lighter or heat gun may be necessary in some cases.**

- *Protective jackets removal jaws:* They are defined by the external dimension of the cable **after** jacket removal. These jaws have a cutting depth adjustment to avoid to cut the braid

Production of special clamps: Possible on request, send us cable samples

Each plier is shipped in a plastic professional case with a set of 6 jaws described below. Selected jaws numbers must be provided with order

Part number

6YTTL04

Jaws spare parts numbers

Jaws for bus wires stripping

Size	Bus wires distance	Wires diameter	Gauge	Marking	Part numbers
<p>A1</p>	2.5 3.8 5 7	1 to 1.5mm	0.5 to 1.5mm ²	A1	6YTTL04A1
<p>A2</p>		1.5 to 1.9mm	2 to 2.5mm ²	A2	6YTTL04A2
<p>A3</p>		1.9 to 2.3mm	2.5 to 4mm ²	A3	6YTTL04A3

Because of permanent improvement of our products, drawings, descriptions, features used on these data sheets are for guidance only and can be modified without prior advice

Exclusive stripping pliers for heat tracing cables with dedicated cutting blades according to all cable dimensions.



Jaws for oblong cables outer and inner jackets removal



Size	Cable outside dimension after jacket removal	Marking	Part numbers	Size	Cable outside dimension after jacket removal	Marking	Part numbers
<p>B1 5mm R2.5mm 10mm</p>	5 × 10mm	B1	6YTTL04B1	<p>B7 1.8mm R0.9mm 9.8mm</p>	1.8 × 9.8mm	B7	6YTTL04B7
<p>B2 2.1mm R1.1mm 7mm</p>	2.1 × 7mm	B2	6YTTL04B2	<p>B8 7.2mm R2mm 12.7mm</p>	7.2 × 12.7mm	B8	6YTTL04B8
<p>B3 5.5mm R2.75mm 10.5mm</p>	5.5 × 10.5mm	B3	6YTTL04B3	<p>B9 3.7mm R2mm 9.3mm</p>	3.7 × 9.3mm	B9	6YTTL04B9
<p>B4 2.2mm R2mm 7.5mm</p>	2.2 × 7.5mm	B4	6YTTL04B4	<p>B10 7.7mm R2mm 12.7mm</p>	7.7 × 12.7mm	B10	6YTTL04B10
<p>B5 6.8mm R3.4mm 10.5mm</p>	6.8 × 10.5mm	B5	6YTTL04B5	<p>B11 4.2mm R2mm 9.3mm</p>	4.2 × 9.3mm	B11	6YTTL04B11
<p>B6 5mm R2.5mm 12mm</p>	5 × 12mm	B6	6YTTL04B6				

Because of permanent improvement of our products, drawings, descriptions, features used on these data sheets are for guidance only and can be modified without prior advice

Guillotine notching plier for cutting the heating zone between the conductors of oblong self-regulating cables

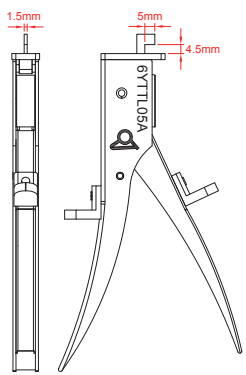
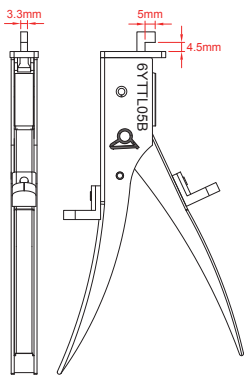
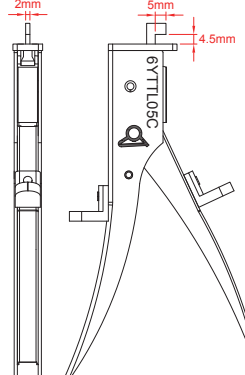
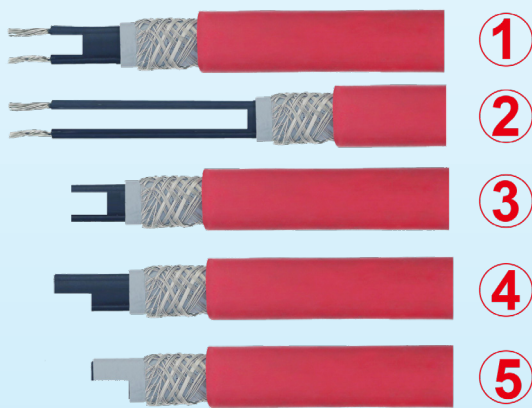
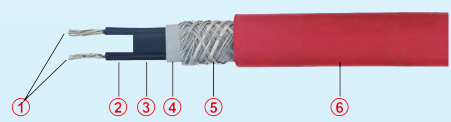

Because of permanent improvement of our products, drawings, descriptions, features used on these data sheets are for guidance only and can be modified without prior advice

Use	Notch width	Cables styles		Type
Workshop or field	1.5mm 2mm 3.3mm	Oblongs, self-regulating		
				
		6YTTL05A	6YTTL05B	6YTTL05C
				
<p>Types of cuts that can be made</p> <ol style="list-style-type: none"> 1: Short section of the heating zone for use in conventional connection boxes. 2: Long section of the heating zone for connection for use in the tube mounting feet. 3: Short section of the heating zone for connection in boxes with insulation piercing system to respect the 5mm distance between bus wires 4: Half-width section of the heating zone for connection in boxes with insulation piercing system to respect the 5mm distance between bus wires. 5: Half-width section with insulation for termination on free end of the cable without silicone gel filling or without RTV filling. 		<p>Common composition of a self-regulating cable</p> <ol style="list-style-type: none"> 1: Metal conductors, from 1 to 2mm². 2: Conductors still covered with semiconductor compound (the one whose stripping is the most difficult). 3: Heating semiconductor area. 4: Electrical insulation jacket of the heating zone. 5: Metal braid or ribbon + earth conductor. 6: Outer protection jacket. 		

Applications

We **specially developed this guillotine hand shear** to solve two specific problems with low and medium temperature self-regulating cables:

- The difficulty of cutting the carbon filled polyethylene heating zone between the 2 bus wires.
 - The obligation to maintain a mandatory insulation distance between the bus wires of these heating cables when they are connected to a terminal block or to one cable end seal. This minimum insulation distance depends on the use of the cable: in an industrial environment in a **non-explosive atmosphere**, this distance can range from 2 to 3.6mm depending on the materials. In an industrial environment and **explosive atmosphere**, using a type EX "e" connection, this minimal distance is 5mm. (See standards EN60079-7 and EN60947).
- This tool allows to **cut easily the polyethylene matrix** to respect these distances in all cases.

Guillotine notching plier for cutting the heating zone between the conductors of oblong self-regulating cables



Main features

According to the different models of the different manufacturers of self-regulating heating cables, the distance between the bus wires is highly variable, ranging from 1.5 to 4.2mm.

Jaws:

Notch length: 5mm for each manual cutting operation.

Notch width: They exist in three configurations, allowing to cover the different spacings between existing between bus wires.

- Cables with distance between bus wires from 1.5 to 2mm.
- Cables with distance between bus wires from 2 to 3.3mm.
- Cables with distance between bus wires from 3.3 to 4.2mm.

This last model also allows cutting cables and conductors according to type 4 and 5 cuts.

Production of special pliers: Possible on request, send us cable samples.

Each guillotine notching plier is delivered in a professional box with a set of cable dimension guides

Part numbers

6YTTL05A	Guillotine notching plier for cables with distance between bus wires from 1.5 to 2mm.
6YTTL05B	Guillotine notching plier for cables with distance between bus wires from 2 to 3.3mm.
6YTTL05C	Guillotine notching plier for cables with distance between bus wires from 2 to 3.3mm and types 4 and 5 cuts.
6YTTL05D	Set of 3 guillotine notching pliers with the 3 sets of jaws.



Tool case

Because of permanent improvement of our products, drawings, descriptions, features used on these data sheets are for guidance only and can be modified without prior advice

Because of permanent improvement of our products, drawings, descriptions, features used on these data sheets are for guidance only and can be modified without prior advice





Because of permanent improvement of our products, drawings, descriptions, features used on these data sheets are for guidance only and can be modified without prior advice

Contact us

www.ultimheat.com



Catalogues collection on
www.ultimheat.com

Electromechanical components & OEM heating sub-assemblies manufacturer

- Mechanical thermostats
- Mechanical safeties single & three poles
- ATEX thermostats & safeties
- Flow through liquid heaters
- Immersion heaters
- Heating elements for air and liquid
- Connection blocks
- Housings for corrosive environments
- Flow switches
- Level switches
- Pressure switches and air switches
- Fusible links and fire detection mechanisms
- Tracing equipment
- **Taylor made solutions**



JUNCTION BOXES, TEMPERATURE CONTROLS & ACCESSORIES FOR HEAT TRACING